



DESCRIPTION

Curtis Model 1254 Pump System Controller is specifically engineered to the unique characteristics of hydraulic motor and valve control. Includes an advanced MOSFET power section and sophisticated microprocessor for high efficiency, silent operation, flexibility and ruggedness.

APPLICATION

The Curtis model 1254 Pump System Controller is ideal for material handling, industrial and man-up platform vehicles.

FEATURES

Smooth Control of Hydraulic Functions

- Pulse-Width Modulation controlled pump motor provides smooth start-up and rampdown on each function. Precise current and voltage control eliminates the bumps and jumps associated with on/off contactor control for increased efficiency and reduced contactor tip and motor brush wear.

Smooth Control of Hydraulic Functions

- Load Compensation automatically varies the applied motor power in response to changes in weight and forces on the pump. Provides better speed regulation empty versus loaded, when picking up mast sections or while multiple functions are engaged.
- A current regulated proportional valve driver provides controlled, continuously variable speed lowering. An additional solenoid driver is provided for load hold or flow control.

Flexible and Programmable

- Up to 8 fixed speed and 3 variable speed inputs for maximum application flexibility. Speed control signals can be additive or prioritized in a myriad of combinations. An additional programmable feature permits a simple interface with a multi-function control handle.
- Fully compatible with all Curtis handheld and PC based programmers for testing, diagnostics and parameter adjustments.

Safety Features

- Meets or exceeds EEC fault detection requirements. Software and hardware circuitry detect faults in the variable speed controls and power section for safe operation.
- Power On Self Test and continuous diagnostics ensure proper operation. Dual watchdog circuits ensure software integrity.
- Programmable minimum speed setting for maintaining steering system pressure and pump lubrication.
- Lift interrupt/Inhibit input can be connected to a Curtis BDI or other interlock function to disable the controller at low battery or when the operator is not present.

MODEL 1254

OPTIONS

- CAN Bus Communication port option allows control and access of all control and status functions through a standard two wire connection. Man-up vehicles can simplify wiring, improve reliability and reduce cost. Complex vehicles can connect multiple modules and share features and functions.
- Optional SepEx[®] (separately excited) pump control allows for increased performance under load. Top speed is better controlled and empty and loaded speeds are brought closer together.

MODEL CHART

Model No*	Voltage Rating (V)	Current Rating 2 Minutes (Amps)	Current Rating 1 Hour (Amps)	Field Current Rating (SepEx [®] Models Only) 2 Minutes (Amps)
1254-44XX	24-36	400	160	40
1254-45XX	24-36	500	180	40
1254-46XX	24-36	600	200	40
1254-47XX	24-36	700	200	40
1254-54XX	36-48	400	150	40
1254-55XX	36-48	500	170	40
1254-56XX	36-48	600	190	40
1254-64XX	36-80	400	140	40
1254-65XX	36-80	500	160	40
1254-66XX	36-80	600	190	40

*Series model designator shown. For other models replace "1254" designator as follows:

- Series = 1254 (shown)
- SepEx = 1254X
- Series CANbus = 1254C
- SepEx CANbus = 1254CX

MODEL 1254

TYPICAL WIRING DIAGRAM

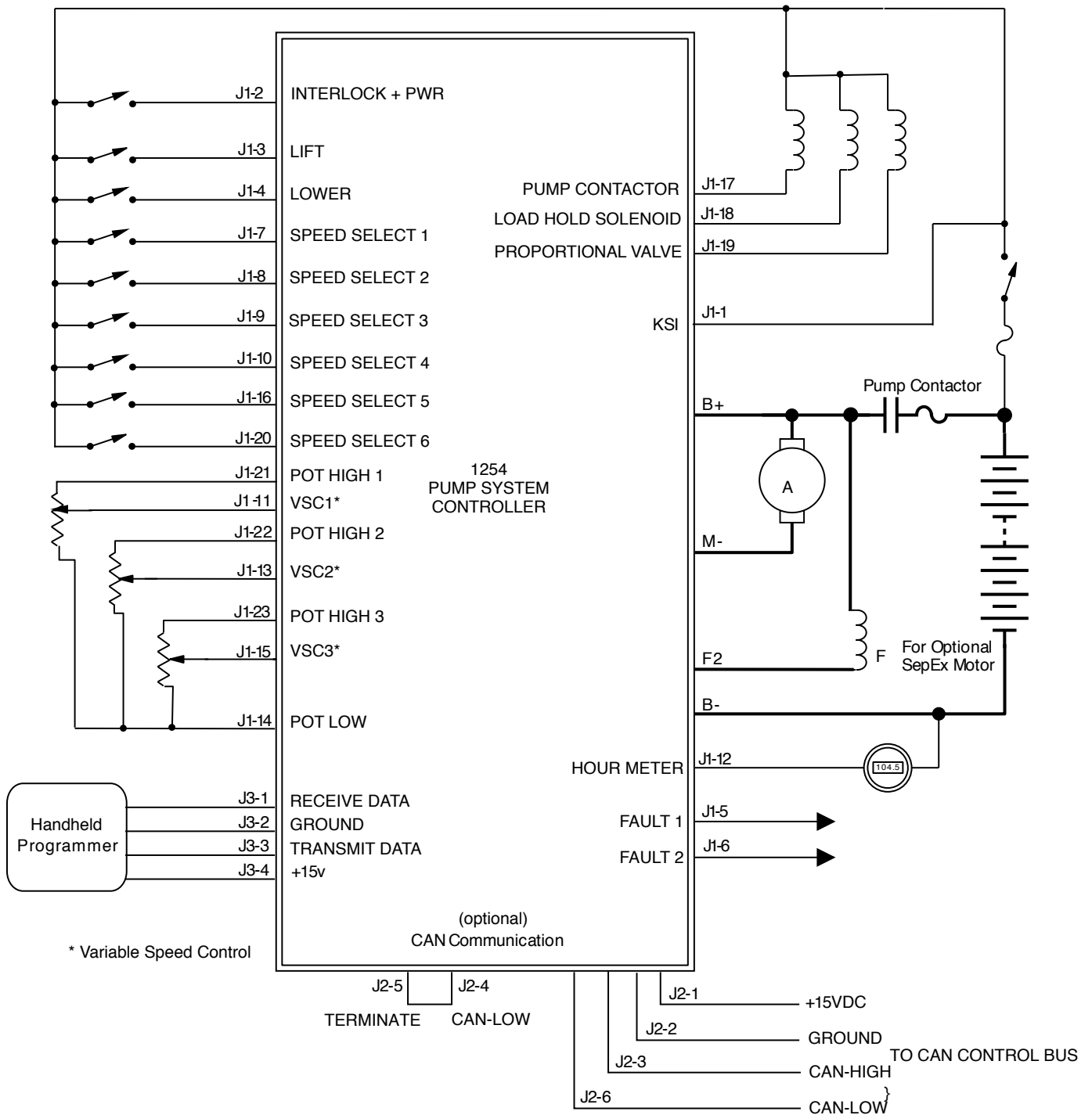

MODEL 1254

DIMENSIONS mm

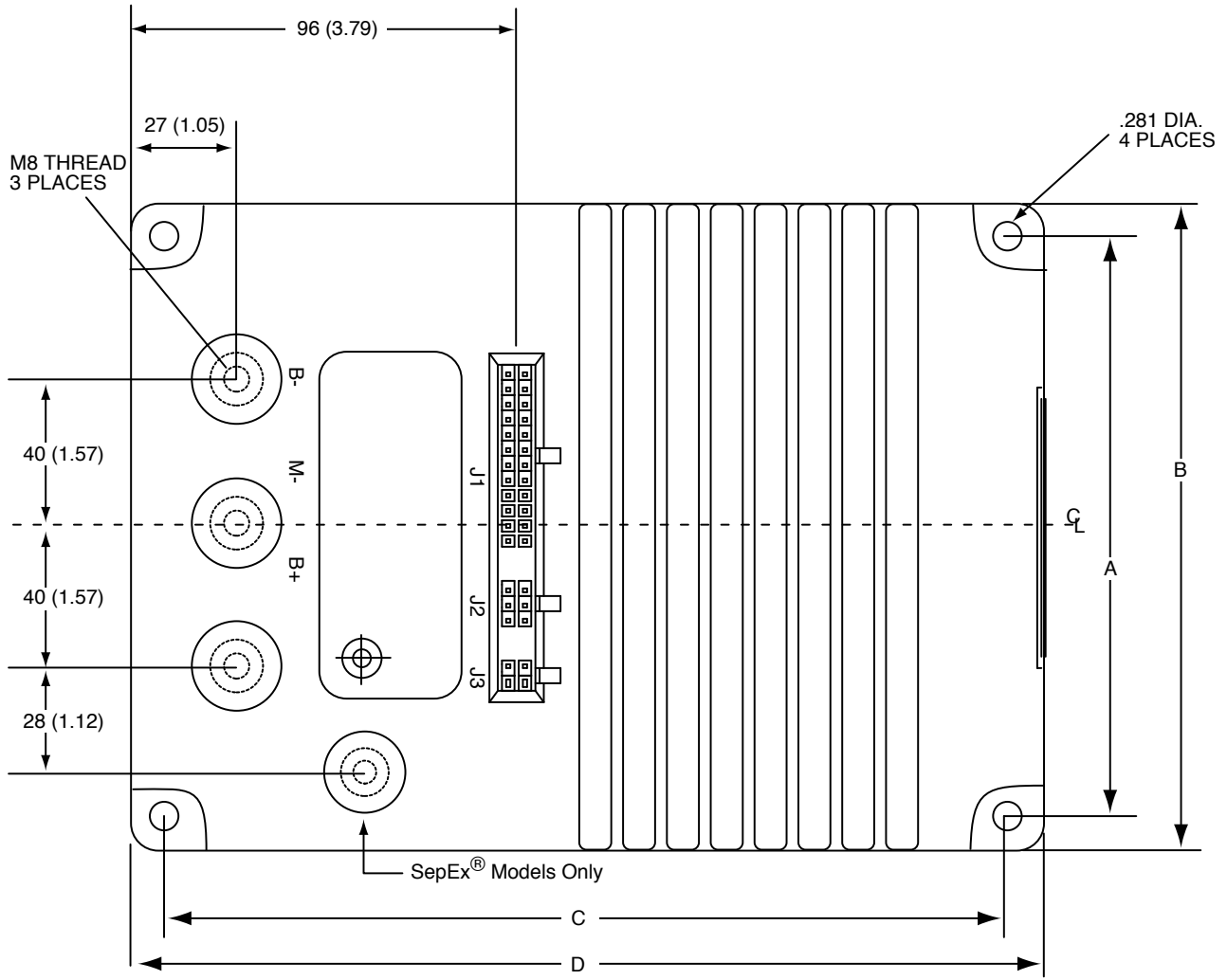

	A	B	C	D
1254	159 (6.25)	178 (7.00)	210 (8.25)	229 (9.00)

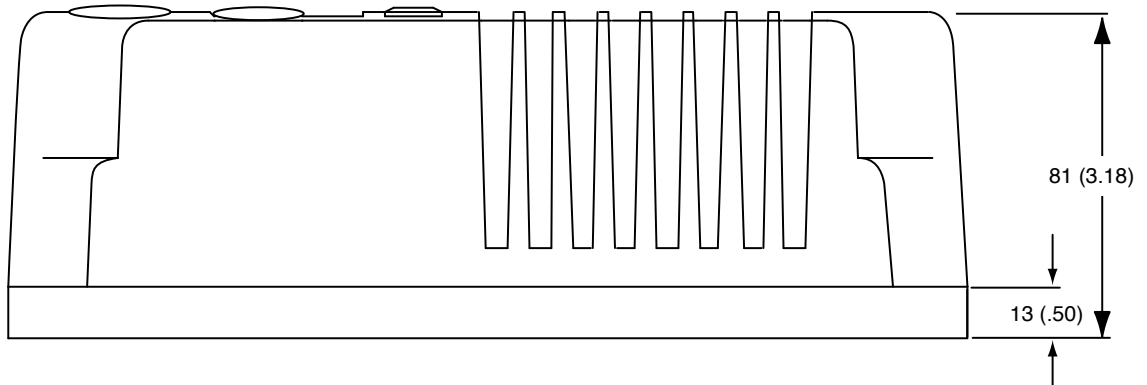

WARRANTY Two year limited warranty from time of delivery.

