

**SEPARATELY EXCITED (SX) TRANSISTORIZED DUAL MOTOR CONTROLLERS
 INSTALLATION AND OPERATION MANUAL
 (IC3645SR3R404P2 & IC3645SR3R404P3)**

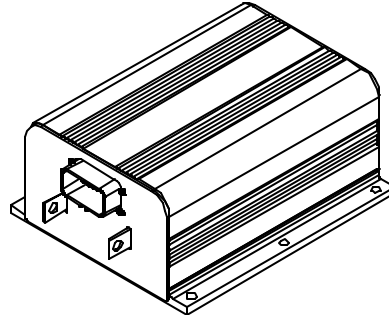

Note: The information contained herein is intended to assist OEM's, Dealers and Users of electric vehicles in the application, installation and service of GE solid-state controllers. This manual does not purport to cover all variations in OEM vehicle types. Nor does it provide for every possible contingency to be met involving vehicle installation, operation or maintenance. For additional information and/or problem resolution, please refer the matter to the OEM vehicle manufacturer through his normal field service channels. Do not contact GE directly for this assistance.

Table of Contents

Copyright by General Electric Company July 1999

Section 1.0	INTRODUCTION	4
1.1	Motor Characteristics	4
1.2	Solid-State Reversing	5
1.3	Flexible System Application	5
1.4	More Features with Fewer Components	5
Section 2.0	FEATURES OF SX FAMILY OF MOTOR CONTROLLERS	5
2.1	Performance	5
2.1.1	Oscillator Card Features	5
2.1.1.a	Standard Operation	5
2.1.1.b	Proportional Operation for Dual Motor Vehicles	6
2.1.1.c	Creep Speed	6
2.1.1.d	Control Acceleration and 1A Time	6
2.1.2	Current Limit	6
2.1.3	Braking	7
2.1.3.a	Plug Braking	7
2.1.3.b	Regenerative Braking to Zero Speed	7
2.1.3.c	Pedal Position Plug Braking	7
2.1.4	Auxiliary Speed Control	7
2.1.4.a	Field Weakening	7
2.1.4.b	Speed Limits	7
2.1.5	Ramp Operation	7
2.1.5.a	Ramp Start	7
2.1.5.b	Anti-Rollback	7

Table of Contents (Continued)

2.1.6	Steer Pump Contactor Time Delay	7
2.1.7	On-Board Coil Drivers and Internal Coil Suppression	7
2.2	System Protective Override.....	7
2.2.1	Static Return to Off (SRO)	7
2.2.2	Accelerator Volts Hold Off	8
2.2.3	Pulse Monitor Trip (PMT).....	8
2.2.4	Thermal Protector (TP).....	8
2.2.5	Low Voltage Detection.....	8
2.3	Diagnostics.....	8
2.3.1	Systems Diagnostics.....	8
2.3.2	Status Codes.....	8
2.3.2.a	Standard Status Codes.....	8
2.3.2.b	Stored Status Codes	8
2.3.3	Hourmeter Readings	8
2.3.4	Battery Discharge Indication (BDI).....	8
2.3.4.a	Internal Resistance Compensation	9
2.3.5	Handset	9
2.3.6	RS-232 Communication Port	9
2.3.7	Circuit Board Coil Driver Modules.....	9
2.3.8	Selectable Truck Modes.....	9
Section 3.0	ORDERING INFORMATION, ELEMENTARY AND OUTLINE DRAWINGS.....	10
3.1	Ordering Information for Separately Excited Controls.....	10
3.2	Outline: SX-2 Package Size.....	11
3.3	Dual Motor Proportioning Drive Elementary.....	12
3.4	Dual Motor Proportioning Drive Input / Output List.....	13
Section 4.0	TROUBLESHOOTING AND DIAGNOSTIC STATUS CODES	14
4.1	General Maintenance Instructions	14
4.2	Cable Routing and Separation	14
4.2.1	Application Responsibility.....	14
4.2.2	Signal/Power Level Definitions.....	14
4.2.2.a	Low Level Signals (Level L).....	14
4.2.2.b	High Level Signals (Level H).....	15
4.2.2.c	Medium-Power Signals (Level MP)	15
4.2.2.d	High-Power Signals (Level HP).....	15
4.2.3	Cable Spacing Guidelines.....	15
4.2.3.a	General Cable Spacing.....	15
4.2.4	Cabling for Vehicle Retrofits.....	15
4.2.5	RF Interference.....	15
4.2.6	Suppression.....	15
4.3	Recommended Lubrication of Pins and Sockets Prior to Installation	15
4.4	General Troubleshooting Instructions	16
4.5	Traction Controller Status Codes.....	17-44
Section 5.0	SX FAMILY - GE HANDSET INSTRUCTIONS	45
5.1	General Features	45
5.2	Purpose/Setup Functions	45
5.3	Setup Function Procedures	45
5.3.1	Setup Mode	46

Table of Contents (Continued)

5.3.2	Status Code Scrolling.....	46
5.3.3	SX Handset Plug Connections & Outline Drawing....	46
5.4	Setup Functions for Traction Controller ..	47-51
5.5	Summary of Current Limit Adjustments.....	52
Section 6.0	DISPLAYS.....	53
6.1	Application	53
6.2	Standard Dash Displays	53
6.2.1	Connections.....	53
6.2.2	Part Numbers	53
6.2.3	Connector Reference Numbers.....	53
6.3	Start-up Display Sequence	53
6.4	Outline Drawings	54
Section 7.0	TURN ANGLE POTENTIOMETER INSTALLATION.....	55
7.1	General.....	55
7.2	270 Degree Potentiometer Input	56
7.3	Turn Angle Input Volts vs. Steer Wheel Degrees vs. Handset Reading	57
Section 8.0	AUTO CALIBRATION OF ACCELERATOR, BRAKE AND STEER ANGLE POTENTIOMETERS	58
8.0	General.....	58
8.1	Calibration of Accelerator Potentiometer.....	58
8.2	Calibration of Steer Angle Potentiometer	58
8.3	Calibration of Brake Potentiometer	58
Section 9.0	MEMORY MAPS	60
9.1	Typical Memory Map for DM Proportioning Control.....	60-62

Section 1. INTRODUCTION

Section 1.1 Motor Characteristics

The level of sophistication in the controllability of traction motors has changed greatly over the past several years. Vehicle manufacturers and users are continuing to expect more value and flexibility in electric vehicle motor and control systems as they are applied today. In order to respond to these market demands, traction system designers have been forced to develop new approaches to reduce cost and improve functions and features of the overall system. Development is being done in a multi-generational format that allows the market to take advantage of today's technology, while looking forward to new advances on the horizon. GE has introduced a second generation system using separately excited DC shunt wound motors. The separately excited DC motor system offers many of the features that are generally found on the advanced AC systems. Historically, most electric vehicles have relied on series motor designs because of their ability to produce very high levels of torque at low speeds. But, as the demand for high efficiency systems increases, i.e., systems that are more closely applied to customers' specific torque requirements, shunt motors are now often being considered over series motors. In most applications, by independently controlling the field and armature currents in the separately excited motor, the best attributes of both the series and the shunt wound motors can be combined.

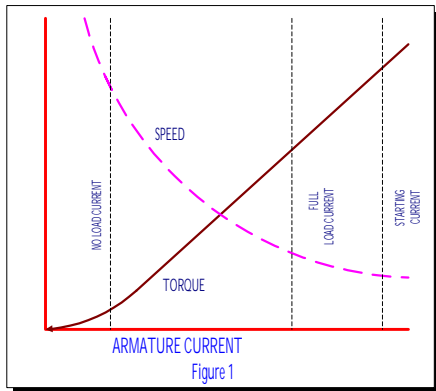

As shown in the typical performance curves of Figure 1, the high torque at low speed characteristic of the series motor is evident.

In a shunt motor, the field is connected directly across the voltage source and is therefore independent of variations in load and armature current. If field strength is held constant, the torque developed will vary directly with the armature current. If the mechanical load on the motor increases, the motor slows down, reducing the back EMF (which depends on the speed, as well as the constant field strength). The reduced back EMF allows the armature

current to increase, providing the greater torque needed to drive the increased mechanical load. If the mechanical load is decreased, the process reverses. The motor speed and the back EMF increase, while the armature current and the torque developed decrease. Thus, whenever the load changes, the speed changes also, until the motor is again in electrical balance.

In a shunt motor, the variation of speed from no load to normal full load on level ground is less than 10%. For this reason, shunt motors are considered to be constant speed motors (Figure 2).

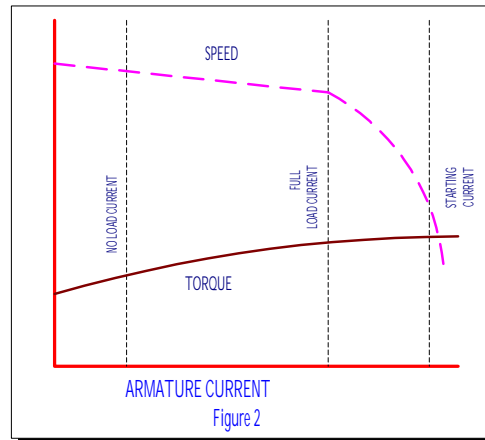

In the separately excited motor, the motor is operated as a fixed field shunt motor in the normal running range. However, when additional torque is required, for example, to climb non-level terrain, such as ramps and the like, the field current is increased to provide the higher level of torque. In most cases, the armature to field ampere turn ratio can be very similar to that of a comparable size series motor (Figure 3.)

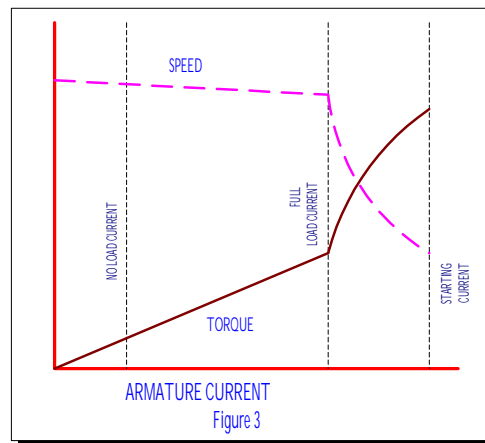

Aside from the constant horsepower characteristics described above, there are many other features that provide increased performance and lower cost. The following description provides a brief introduction to some of these features.

Section 1. 2 Solid-State Reversing

The direction of armature rotation on a shunt motor is determined by the direction in which current flows through the field windings. Because of the shunt motor field, typically only requires about 10% of the armature current at full torque, it is normally cost effective to replace the double-pole, double-throw reversing contactor with a low power transistor H-Bridge circuit (Figure 4).

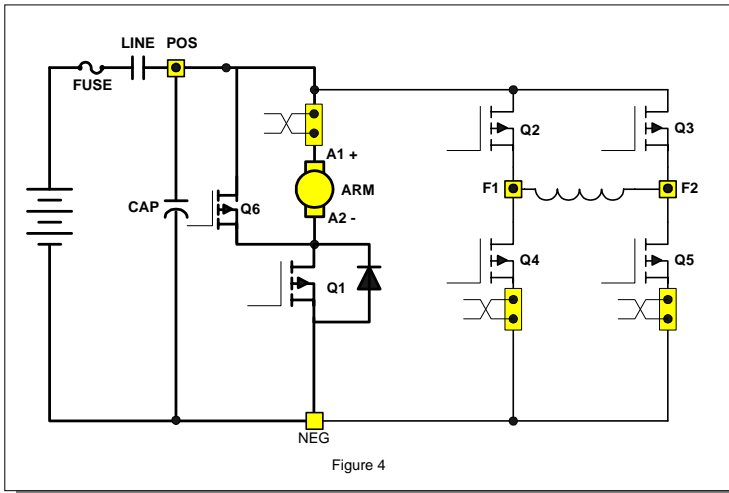

By energizing the transistors in pairs, current can be made to flow in either direction in the field. The field and armature control circuits typically operate at 12KHZ to 15KHZ, a frequency range normally above human hearing. This high frequency, coupled with the elimination of directional contactors, provides for very quiet vehicle operation.

The line contactor is normally the only contactor required for the shunt motor traction circuit. This contactor is used for both pre-charge of the line capacitors and for emergency shut down of the motor circuit, in case of problems that would cause a full motor torque condition. The line can be energized and de-energized by the various logic combinations of the vehicle, i.e. activate on key, seat or start switch closure, and de-energize on time out of idle vehicle. Again, these options add to the quiet operation of the vehicle.

Section 1. 3 Flexible System Application

Because the shunt motor controller has the ability to control both the armature and field circuits independently, the system can normally be adjusted for maximum system efficiencies at certain operating parameters. Generally speaking, with the ability to independently control the field and armature, the motor performance curve can be maximized through proper control application.

Section 1. 4 More Features with Fewer Components

Field weakening with a series wound motor is accomplished by placing a resistor in parallel with the field winding of the motor. Bypassing some of the current flowing in the field into the resistor causes the field current to be less, or weakened. With the field weakened, the motor speed will increase, giving the effect of "overdrive". To change the "overdrive speed", it is necessary to change the resistor value. In a separately excited motor, independent control of the field current provides for infinite adjustments of "overdrive" levels, between the motor base speed and maximum weak field. The desirability of this feature is enhanced by the elimination of the contactor and resistor required for field weakening with a series motor.

With a separately excited motor, overhauling speed limit, or downhill speed, will also be more constant. By its nature, the shunt motor will try to maintain a constant speed downhill. This characteristic can be enhanced by increasing the field strength with the control. Overhauling load control works in just the opposite way of field weakening, as armature rotation slows with the increase of current in the field. An extension of this feature is a zero-speed detect feature which prevents the vehicle from free-wheeling down an incline, should the operator neglect to set the brake.

Regenerative braking (braking energy returned to the battery) may be accomplished completely with solid-state technology. The main advantage of regenerative braking is increased motor life. Motor current is reduced by 50% or better during braking while maintaining the same braking torque as electrical braking with a diode clamp around the armature. The lower current translates into longer brush life and reduced motor heating. Solid state regenerative braking also eliminates a power diode, current sensor and contactor from the circuit.

For GE, the future is now, as we make available a new generation of electric traction motor systems for electric vehicles having separately excited DC shunt motors and controls. Features that were once thought to be only available on future AC or brushless DC technology vehicles systems are now achievable and affordable.

Section 2. FEATURES OF SX FAMILY OF TRANSISTOR MOTOR CONTROLLERS

Section 2.1 Performance

Section 2.1.1 Oscillator Card Features

Section 2.1.1.a Standard Operation

The oscillator section of the card has two adjustable features, creep speed and minimum field current. With the accelerator at maximum ohms or volts, the creep speed can be adjusted by Function 2 of the Handset or a trimpot. The field control section allows the adjustment of the field weakening level in order to set the top speed of the motor. This top speed function (Minimum Field Current) is enabled when the armature current is less than the value set by Function 24 and the accelerator input voltage is less than 1 volt. Top Speed can be adjusted by Function 7 of the Handset or a trimpot.

The % ON-time has a range of approximately 0 to 100 percent. The SX controllers operate at a constant frequency and the % ON-time is controlled by the pulse width of the voltage/current applied to the motor circuits.

Section 2.1.1.b Proportional Operation for Dual Motor Vehicles

A key performance advantage of this control is the ability to achieve actual "proportioning" of motor speed. In a non-proportioning, or single control, system, when the vehicle starts to turn, the outside drive wheel turns in a larger circle than the inside wheel. Depending on the geometry of the vehicle, at some degree of turn angle, the inside wheel must slow down to prevent scrubbing of the wheel. This is accomplished on a single control system by disconnecting the inside motor and letting the wheel "free wheel" or "float" at whatever speed is dictated by the outside wheel that is still under power. The main disadvantage of this system is that no torque is available on that motor when the inside wheel is in the "free wheel" mode, and the vehicle performance in a turn is reduced. When the steer wheel nears the 90° turn angle, the inside motor is re-connected in the opposite direction of the outside wheel. At this point, torque is returned to the inside wheel and the speed is the same on both motors.

With two controls, the speed of each motor can be regulated independently. The driver controls the speed of the outside wheel with the accelerator input signal. The inside wheel speed is controlled by the turn angle of the steer wheel. A potentiometer is attached to the steer wheel in order to communicate the steer angle to the controllers. During vehicle manufacture, software selection identifies each control for its application as a right or left control. The controls are physically identical, and it is only software that separates a right from a left control, or differentiates a control for a dual motor application from one intended for a single motor vehicle.

With this dual motor system, as the steer reaches some pre-selected turn angle, approximately 15°, the speed of the inside wheel decreases proportionally to the speed of the outside wheel. This proportional decline will continue on a tangential path, until the steer angle reaches another

predetermined angle of approximately 70°. At this point, the inside wheel will stop. As the steer angle is increased toward the 90° point, the inside wheel will reverse direction and start to accelerate proportionally in speed. As the steer angle reaches the 90° point, the inside wheel speed will be the same as that of the outside wheel. During this entire turn, except for several degrees when the motor was stopped to reverse direction, torque was always present on the inside wheel, providing a smoother ride throughout the turning radius of the vehicle.

Details for the adjustment of the steer angle potentiometer can be found in Section 7 of this manual.

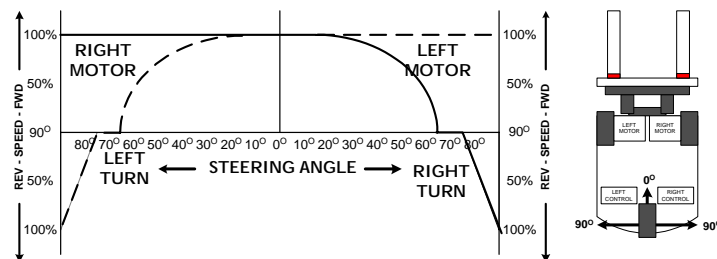

Section 2.1.1.c Creep Speed

With the accelerator at minimum speed, the creep speed can be adjusted by Function 2 of the Handset. At creep speed, the ON time can be decreased to approximately 5%, with the OFF time at approximately 95%. At full transistor operation, this condition will be reversed (short OFF time, long ON time). This variation of ON and OFF time of the oscillator varies the voltage applied to the motor, thereby varying the speed of the motor for a given load.

Section 2.1.1.d Control Acceleration

This feature allows for adjustment of the rate of time it takes for the control to accelerate to 100% applied battery voltage to the motor on hard acceleration. Armature C/A is adjusted by Function 3 from 0.1 to 6 seconds.

Section 2.1.2 Current Limit

This circuit monitors motor current by utilizing sensors in series with the armature and field windings. The information detected by the sensor is fed back to the card so that current may be limited to a preset value. If heavy load currents are detected, this circuit overrides the oscillator and limits the average current to a value set by Function 4 and Function 8 of the Handset. The C/L setting is based on the maximum thermal rating of the control. Because of the flyback current through Q6, the motor current is usually greater than battery current, except at 100% ON time.

Section 2.1.3 Braking

Section 2.1.3.a Plug Braking

Slow down is accomplished when reversing direction by providing a small amount of retarding torque for deceleration. If the vehicle is moving, and the directional lever is moved from one direction to the other, the plug signal is initiated. Once the plug signal has been initiated, the field is reversed, and the armature current is regulated to the plug current limit as set by Function 5. Armature current is regulated by increasing the field current as the vehicle slows down. Once the field current reaches a preset value, set by Function 10, and armature plug current can no longer be maintained, the braking function is canceled, and the control reverts back to motoring. All energy produced by the motor during plugging is dumped as heat into the motor in this braking mode.

Section 2.1.3.b Regenerative Braking to Zero Speed

Slow down is accomplished when reversing direction by providing a small amount of retarding torque for deceleration. If the vehicle is moving, and the directional lever is moved from one direction to the other, the regen signal is initiated. Once the regen signal has been initiated, the field current is increased. Armature current is regulated to the regen current limit as set by Function 9. As the vehicle slows down, the field current continues to increase, and transistor Q2 begins to chop. The field current will increase until it reaches a preset value set by Function 10, and transistor Q2 on-time will increase until it reaches 100% on-time. Once both of the above conditions have been met, and the regen current limit can no longer be maintained, the braking function is canceled. The fields will then reverse, and the control reverts back to motoring.

Part of the energy produced by the motor during regen is returned to the battery, and the remainder is dumped into the motor as heat.

Section 2.1.3.c Pedal Position Plug Braking

This feature allows control of the plugging distance based on pedal position when there has been a "directional switch" change. Pedal position will reduce the plugging current as the pedal is returned to the creep speed position. Maximum plug current is obtained with the accelerator in the top speed position.

Section 2.1.4 Auxiliary Speed Control

Section 2.1.4.a Field Weakening

This function allows the adjustment of the field weakening level in order to set the top speed of the motor. The function is enabled when the armature current is less than the value

set by Function 24. It is important to note that this function is used to optimize motor and control performance, and this setting will be determined by GE and OEM engineers at the time of vehicle development. *This setting must not be changed by field personnel without the permission of the OEM.*

Section 2.1.5 Ramp Operation

Section 2.1.5.a Ramp Start

This feature provides maximum control torque to restart a vehicle on an incline. The memory for this function is the directional switch. When stopping on an incline, the directional switch must be left in its original or neutral position to allow the control to initiate full power when restarted. The accelerator potentiometer input will modulate ramp start current.

Section 2.1.5.b Anti-Rollback

This feature provides retarding torque to limit rollback speed in the non-travel direction when the ACC pedal is released when stopping on a grade, or when the brake pedal is released when starting on a grade. This feature forces the vehicle to roll very slowly down the grade when the accelerator or brake is released. Because the vehicle can gain significant speed during roll-back, the torque needed to re-start on the ramp is lower than an unrestricted roll-back speed.

Section 2.1.6 Steer Pump Contactor Time Delay

This feature provides a 0.5 to 63 second time delayed drop out of the steer pump contactor when the seat switch is opened.

Section 2.1.7 On-Board Coil Drivers and Internal Coil Suppression

Coil drivers for the LINE and SP or BYPASS contactors are on-board the control card. These contactors must have coils rated for the vehicle battery volts.

Section 2.2 System Protective Override

Section 2.2.1 Static Return to Off (SRO)

This inherent safety feature of the control is designed to require the driver to return the directional lever to the neutral position anytime he leaves the vehicle and returns. Additionally, if the seat switch or key switch is opened, the control shuts off and cannot be restarted until the directional lever is returned to neutral. A time delay of approximately 2 seconds is built into the seat switch input to allow momentary opening of the seat switch, if a bump is encountered.

Section 2.2.2 Accelerator Volts Hold Off

This feature checks the voltage level at the accelerator input whenever the key switch or seat switch is activated. If, at start-up, the voltage is greater than 0.9 volts, the control will not operate. This feature assures that the control is calling for low speed operation at start up.

Section 2.2.3 Pulse Monitor Trip (PMT)

The PMT design contains three features which shut down, or lock out, control operation if a fault conditions occurs that would cause a disruption of normal vehicle operation:

- Look ahead
- Look again
- Automatic look again and reset

The PMT circuit will not allow the control to start under the following conditions:

- The control monitors both armature and field FET's at start-up and during running.
- The control will not allow the line contactor to close at start-up, or will drop it out during running, if either the armature or field FET's are defective, so as to cause uncontrolled truck movement.

Section 2.2.4 Thermal Protector (TP)

This temperature sensitive device is internal to the power transistor (Q1) module. If the transistor's temperature begins to exceed the design limits, the thermal protector will lower the maximum current limit to 200 amps. As the control cools, the thermal protector will automatically reset, returning the control to full power.

Section 2.2.5 Low Voltage Detection

Batteries under load, particularly if undersized or more than 80 percent discharged, will produce low voltages at the control terminals. The SX control is designed for use down to 50 percent of a nominal battery voltage of 36-84 volts, and 75 percent of a nominal battery voltage of 24 volts. Lower battery voltage may cause the control to operate improperly, however, the resulting PMT should open the Line contactor, in the event of a failure.

Section 2.3 Diagnostics

Section 2.3.1 Systems Diagnostics

The control detects the system's present operating status and this status can be displayed to either the Dash Display or the Handset. There are over 70 status codes that are available with the SX systems using Pump and Traction controls and the Truck Management Module (TMM).

Along with the status code display from the TMM, the SX control is capable of reducing the current to the motor, alerting the operator of a critical fault condition.

Section 2.3.2 Status Codes

Section 2.3.2.a Standard Status Codes

The SX control has a wide variety of Status Codes that assist the service technician and operator in trouble shooting the vehicle. If mis-operation of the vehicle occurs, a status code will be displayed on the Dash Display for vehicles so equipped, or be available from the status code displayed when the Handset is plugged into the "Y" plug of the logic card.

With the status code number, follow the procedures outlined in DIAGNOSTIC STATUS CODES to determine the problem and appropriate corrective action.

Note: The Status Code Instruction Sheets do not purport to cover all possible causes of a display of a "status code". They do provide instructions for checking the most direct inputs that can cause status codes to appear.

Section 2.3.2.b Stored Status Codes

This feature records the last 16 "Stored Status Codes" that have caused a PMT controller shut down and/or disrupted normal vehicle operation. (PMT type faults are reset by cycling the key switch). These status codes, along with the corresponding BDI and hourmeter readings, can be accessed with the Handset, or by using the RS 232 communications port and dumping the information to a Personal Computer terminal.

Section 2.3.3 Hourmeter Readings

This feature will display the recorded hours of use of the traction and pump control to the Dash Display each time the key switch is turned off.

Section 2.3.4 Battery Discharge Indication (BDI)

The latest in microprocessor technology is used to provide accurate battery state of charge information and to supply passive and active warning signals to the vehicle operator. Features and functions:

- Displays 100 to 0 percent charge.
- Display blinks with 20% charge. Disables pump circuit with 10% charge. Auto ranging for 36/48 volt operation. Adjustable for use on 24 to 80 volts.

Section 2.3.4.a Internal Resistance Compensation

This feature is used when the Battery Discharge Indicator is present. Adjustment of this function optimizes BDI with among different brands of batteries.

Section 2.3.5 Handset

This is a multi-functional tool used with the LX, ZX, and SX Series GE solid state controls. The Handset consists of a Light Emitting Diode (LED) display and a keyboard for data entry. Note, for ordering purposes, a separate handset part number is required for SX controls.

Features and functions:

- Monitor existing system status codes for both traction and pump controls. Monitor intermittent random status codes.
- Monitor battery state of charge, if available.
- Monitor hourmeter reading on traction and pump controls.
- Monitor or adjust the control functions.

Section 2.3.6 RS232 Communication Port

The serial communication port is used for communication between the two controllers for the transmission of fault codes, confirmation of setup parameters and start-up diagnostics. It can also be used to change control set-up parameters.

Section 2.3.7 Circuit Board Coil Driver Modules

Coil drivers are internal to the control card, and are the power devices that operate the Line, 1A and SP contactor coils. On command from the control card, these drivers initiate opening and closing the contactor coils. All driver modules are equipped with reverse battery protection, such that, if the battery is connected incorrectly, the contactors can not be closed electrically.

Section 2.3.8 Selectable Truck Modes

Through the adjustment of Function 1 of the controller, the following truck parameters are automatically adjusted to the values set below:

Description	Mode 1	Mode 2	Mode 3
Function 1 Setting	0 - 63	64 - 127	128 - 255
C/A Rate	Function 48 of Handset Function 97 of Computer	Function 53 of Handset Function 102 of Computer	Function 58 of Handset Function 107 of Computer
FW Start	Function 49 of Handset	Function 54 of Handset	Function 59 of Handset

	Function 98 of Computer	Function 103 of Computer	Function 108 of Computer
Minimum Field	Function 50 of Handset Function 99 of Computer	Function 55 of Handset Function 104 of Computer	Function 60 of Handset Function 109 of Computer
Ratio	Function 51 of Handset Function 100 of Computer	Function 56 of Handset Function 101 of Computer	Function 61 of Handset Function 110 of Computer
Regen Current Limit	Function 52 of Handset Function 101 of Computer	Function 57 of Handset Function 106 of Computer	Function 62 of Handset Function 111 of Computer

Section 3.0 ORDERING INFORMATION, ELEMENTARY AND OUTLINE DRAWINGS

Section 3.1 Ordering Information for Separately Excited Controls

Example:

Part Number:	IC3645	SE	4	D	33	2	C3
Argument Number:	01	02	03	04	05	06	07

Argument 01: Basic Electric Vehicle Control Number

Argument 02: Control Type:
 SH = Separately Excited Control (Plugging)
 SR = Separately Excited Control (Regen to Zero)

Argument 03: Operating Voltage:

1 = 120 volts	5 = 36/48 volts
2 = 24 volts	6 = 24/36 volts
3 = 36 volts	7 = 72/80 volts
4 = 48 volts	

Argument 04: Package Size:

D = 6.86" X 6.67"
R = 6.86" X 8.15"
U = 8.66" X 8.13"
W = 8.66" X 10.83"

Argument 05: Armature Current
 (2 characters)

22 = 220 Amps
33 = 330 Amps
40 = 400 Amps

etc.

Argument 06: Field Current
 (1 character)

2 = 20 Amps
3 = 30 Amps
4 = 40 Amps

etc.

Argument 07: Customer / Revision

A1 = Customer A / Revision 1
B1 = Customer B / Revision 1

etc.

Section 3.2 Outline: SX-2 Package Size

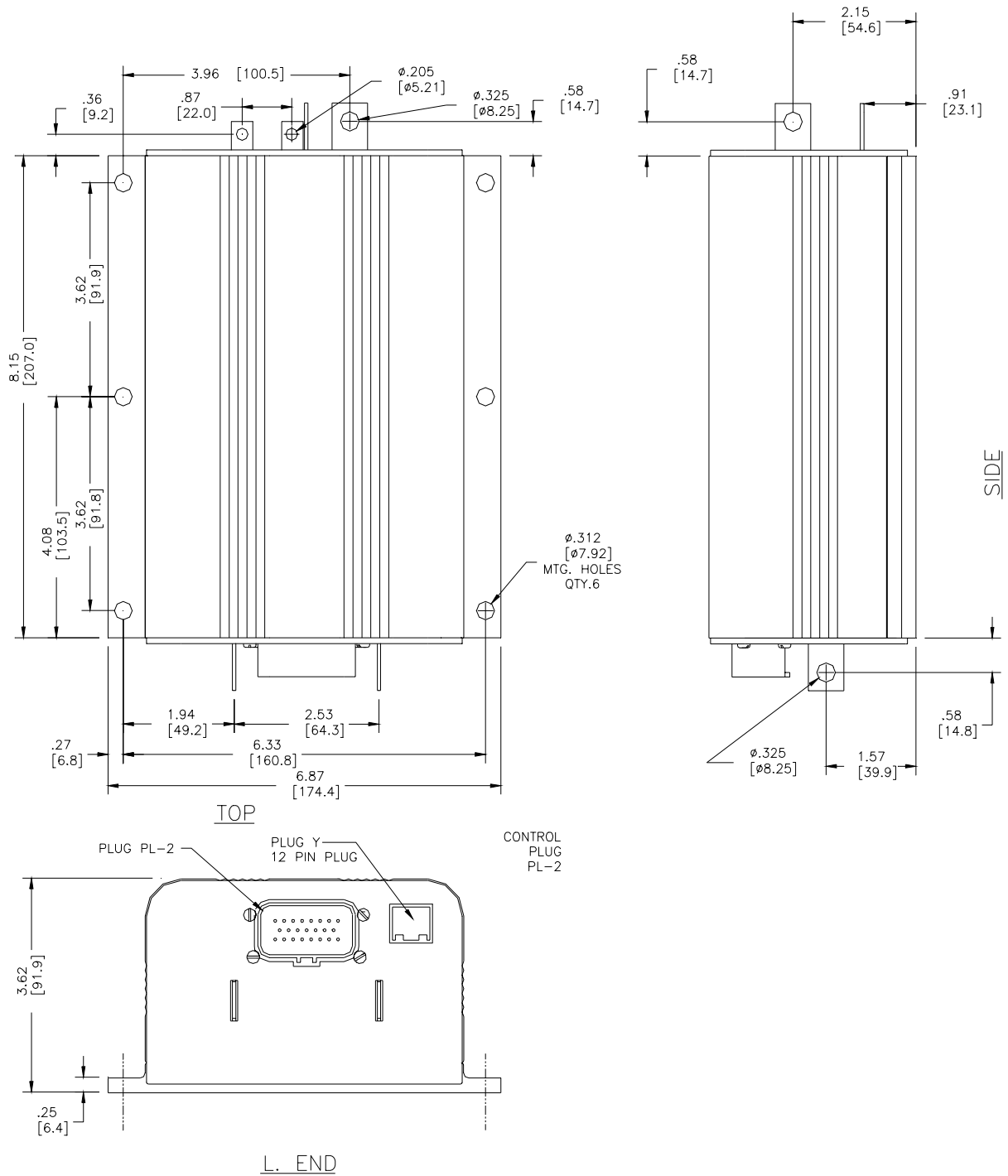

Section 3.3 Dual Motor Proportioning Drive Elementary

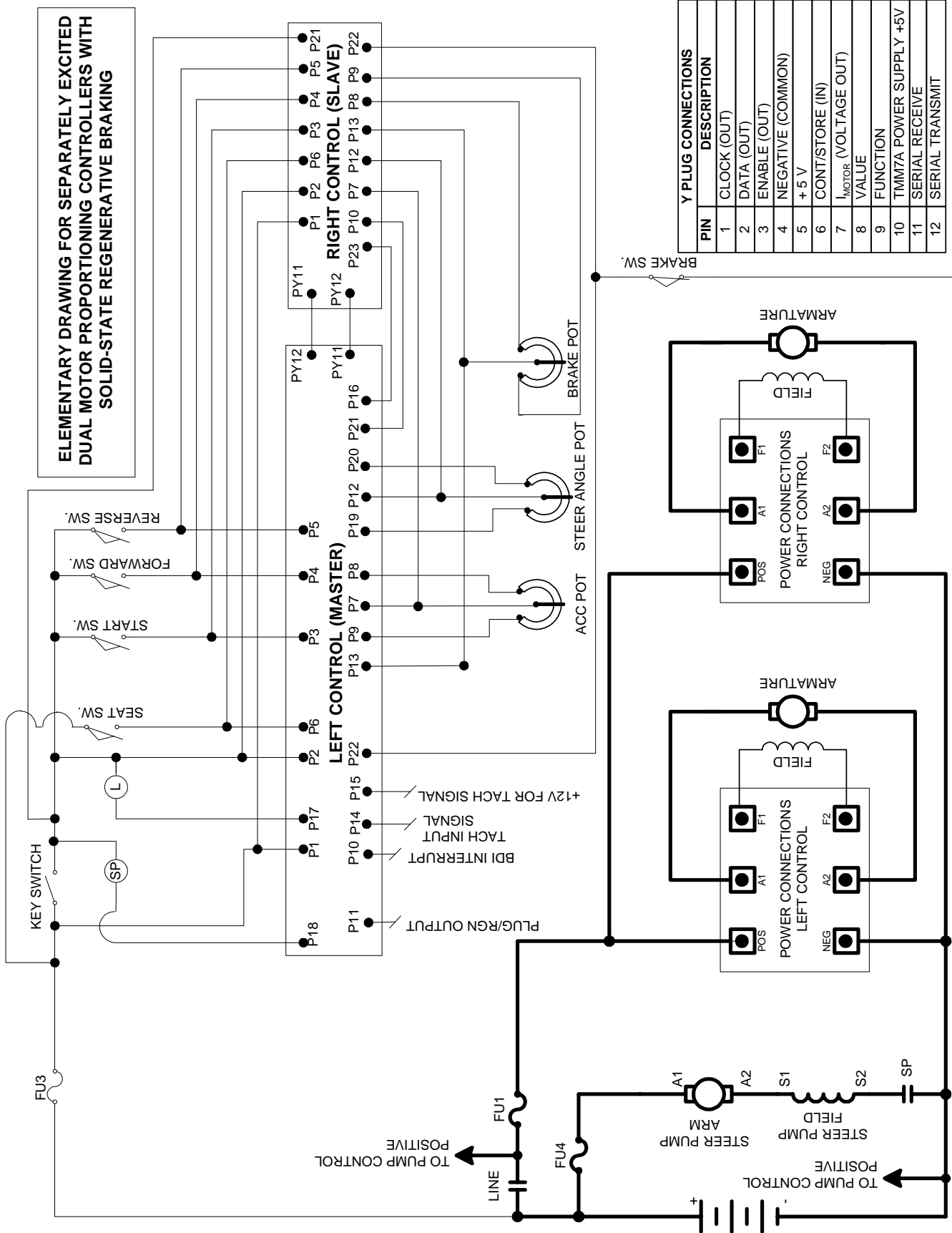

ELEMENTARY DRAWING FOR SEPARATELY EXCITED
 DUAL MOTOR PROPORTIONING CONTROLLERS WITH
 SOLID-STATE REGENERATIVE BRAKING

PIN	DESCRIPTION
1	CLOCK (OUT)
2	DATA (OUT)
3	ENABLE (OUT)
4	NEGATIVE (COMMON)
5	+5 V
6	CONT/STORE (IN)
7	I _{MOTOR} (VOLTAGE OUT)
8	VALUE
9	FUNCTION
10	TMM7A POWER SUPPLY +5V
11	SERIAL RECEIVE
12	SERIAL TRANSMIT

Section 3.4 Dual Motor Proportioning Drive Control Input/Output List

Connections to Main Plug (23 Pin) and "Y" Plug (12 Pin)

STANDARD DUAL MOTOR PROPORTIONING MAIN PLUG INPUT/OUTPUT DESCRIPTION	
PIN	
1	BATTERY VOLTS FROM BATTERY
2	BATTERY VOLTS FROM KEY
3	BATTERY VOLTS FROM START SWITCH
4	BATTERY VOLTS FROM FORWARD SWITCH
5	BATTERY VOLTS FROM REVERSE SWITCH
6	BATTERY VOLTS FROM SEAT SWITCH
7	ACCELERATOR INPUT VOLTAGE SIGNAL
8	ACCELERATOR/BRAKE POTNEGATIVE
9	ACCELERATOR/BRAKE POT +5 VOLTS SUPPLY
10	BDI INTERRUPT/PMT ENABLE
11	PLUG/REGEN OUTPUT SIGNAL +12V
12	STEER ANGLE POT WIPER
13	BRAKE POT WIPER
14	TACHOMETER INPUT SIGNAL
15	TACHOMETER +12 VOLTS SUPPLY
16	MOTOR CURRENT COMPENSATION
17	LINE CONTACTOR DRIVER AND SUPPRESSION
18	STEER PUMP CONTACTOR DRIVER AND SUPPRESSION
19	STEER ANGLE POTENTIOMETER +5V SUPPLY
20	STEER ANGLE POTENTIOMETER NEGATIVE
21	PMT SIGNAL FROM SLAVE/SLAVE KEY
22	BRAKE SWITCH INPUT
23	MOTOR CURRENT
MOTOR TRACTION "Y" PLUG INPUT/OUTPUT DESCRIPTION	
PIN	
1	CLOCK (OUT) (DASH DISPLAY-4)
2	DATA (OUT) (DASH DISPLAY-3)
3	ENABLE (OUT) (DASH DISPLAY-1)
4	NEGATIVE (DASH DISPLAY-2)
5	+5V SUPPLY (DASH DISPLAY-5)
6	CONT/STORE (IN) (HANDSET)
7	MOTOR CURRENT
8	VALUE (TMMA-9)
9	FUNCTION (TMMA-7)
10	MOTOR CURRENT COMPENSATION
11	SERIAL RECEIVE
12	SERIAL TRANSMIT

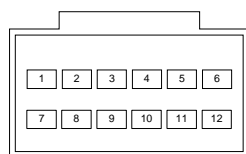

WIRE END VIEW "Y" PLUG

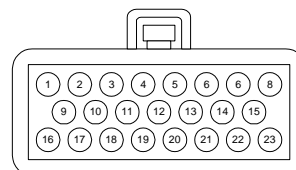

WIRE END VIEW - MAIN PLUG

Section 4.0 TROUBLESHOOTING AND DIAGNOSTIC STATUS CODES

Section 4.1 General Maintenance Instructions

The transistor control, like all electrical apparatus, does have some thermal losses. The semiconductor junctions have finite *temperature* limits, above which these devices may be damaged. For these reasons, normal maintenance should guard against any action which will expose the components to excessive heat and/or those conditions which will reduce the heat dissipating ability of the control, such as restricting air flow.

The following Do's and Don't's should be observed:

Any controls that will be applied in ambient temperatures over 100° F (40° C) should be brought to the attention of the vehicle manufacturer.

All external components having inductive coils must be filtered. Refer to vehicle manufacturer for specifications.

The wiring should not be directly steam cleaned. In dusty areas, blow low-pressure air over the control to remove dust. In oily or greasy areas, a mild solution of detergent or denatured alcohol can be used to wash the control, and then low-pressure air should be used to completely dry the control.

For the control to be most effective, it must be mounted against the frame of the vehicle. The metal vehicle frame, acting as an additional heat sink, will give improved vehicle performance by keeping the control package cooler. *Apply a thin layer of heat-transfer grease (such as Dow Corning 340) between the control heat sink and the vehicle frame.*

Control wire plugs and other exposed transistor control parts should be kept free of dirt and paint that might change the effective resistance between points.

CAUTION: *The vehicle should not be plugged when the vehicle is jacked up and the drive wheels are in a free wheeling position. The higher motor speeds can create excessive voltages that can be harmful to the control.*

Do not hipot (or megger) the control. Refer to control manufacturer before hipotting.

Use a lead-acid battery with the voltage and ampere hour rating specified for the vehicle. Follow normal battery maintenance procedures, recharging before 80 percent discharged with periodic equalizing charges.

Visual inspection of GE contactors contained in the traction and pump systems is recommended to occur during every

160 hours of vehicle operation. Inspection is recommended to verify that the contactors are not binding and that the tips are intact and free of contaminants.

GE does not recommend that any type of welding be performed on the vehicle after the installation of control(s) in the vehicle. GE will not honor control failures during the warranty period when such failures are attributed to welding while the control is installed in the vehicle.

Section 4.2 Cable Routing and Separation

Electrical noise from cabling of various voltage levels can interfere with a microprocessor-based control system. To reduce this interference, GE recommends specific cable separation and routing practices, consistent with industry standards.

Section 4.2.1 Application Responsibility

The customer and customer's representative are responsible for the mechanical and environmental locations of cables. They are also responsible for applying the level rules and cabling practices defined in this section. To help ensure a lower cost, noise-free installation, GE recommends early planning of cable routing that complies with these level separation rules.

On new installations, sufficient space should be allowed to efficiently arrange mechanical and electrical equipment.

On vehicle retrofits, level rules should be considered during the planning stages to help ensure correct application and a more trouble-free installation.

Section 4.2.2. Signal/Powerlevel Definitions

The signal/power carrying cables are categorized into four defining levels: low, high, medium power, and high power. Within those levels, signals can be further divided into classes.

Sections 4.2.2.a through 4.2.2.d define these levels and classes, with specific examples of each. Section 4.2.3 contains recommendations for separating the levels.

Section 4.2.2.a Low-Level Signals (Level L)

Low-level signals are designated as *level L*. These consist of:

- Analog signals 0 through ± 15 V
- Digital signals whose logic levels are less than 15 V DC
- 4 – 20 mA current loops
- DC busses less than 15 V and 250 mA

The following are specific examples of level L signals used in drive equipment cabling:

- Control common tie

- DC buses feeding sensitive analog or digital hardware
- All wiring connected to components associated with sensitive analog hardware with less than 5V signals (for example, potentiometers and tachometers)
- Digital tachometers and resolvers
- Dash display cabling
- RS-232 cabling

Note: Signal inputs to analog and digital blocks should be run as shielded twisted-pair (for example, inputs from tachometers, potentiometers, and dash displays).

Section 4.2.2.b High-Level Signals (Level H)

High-level signals are designated as *level H*. These signals consist of:

- Analog and digital signals greater than 15 V DC and less than 250 mA

For example, switch inputs connected to battery volts are examples of level H signals used in drive equipment cabling.

Section 4.2.2.c Medium-Power Signals (Level MP)

Medium power signals are designated as *level MP*. These signals consist of:

- DC switching signals greater than 15 V
- Signals with currents greater than 250 mA and less than 10A

The following are specific examples of level MP signals used in drive equipment cabling:

- DC busses less than 10 A
- Contactor coils less than 10 A
- Machine fields less than 10 A

Section 4.2.2.d High Power Signals (Level HP)

Power wiring is designated as *level HP*. This consists of DC buses and motor wiring with currents greater than 10 A.

The following are specific examples of level HP signals used in drive equipment cabling:

- Motor armature loops
- DC outputs 10 A and above
- Motor field loops 10 A and above

Section 4.2.3. Cable Spacing Guidelines

Recommended spacing (or clearance) between cables (or wires) is dependent on the level of the wiring inside them. For correct level separation when installing cable, the customer must apply the **general guidelines** (section 4.2.3.a), outlined below.

Section 4.2.3.a General Cable Spacing

The following general practices should be used for *all levels* of cabling:

- All cables and wires of like signal levels and power levels must be grouped together.
- In general, different levels must run in separate wire bundles, as defined in the different classes, identified above. Intermixing cannot be allowed, unless noted by exception.
- Interconnecting wire runs should carry a level designation.
- If wires are the same level and same type signal, group those wires from one location to any other location together in multiconductor cables or bind them together with twine or zip-ties.
- When unlike signals must cross, cross them in 90° angles at a maximum spacing. Where it is not possible to maintain spacing, place a grounded steel barrier between unlike levels at the crossover point.

Section 4.2.4 Cabling for Vehicle Retrofits

Reducing electrical noise on vehicle retrofits requires careful planning. Lower and higher levels should never encircle each other or run parallel for long distances.

It is practical to use existing wire runs or trays as long as the level spacing (see section 5-4) can be maintained for the full length of the run.

Existing cables are generally of high voltage potential and noise producing. Therefore, route levels L and H in a path separate from existing cables, whenever possible.

For level L wiring, use barriers in existing wire runs to minimize noise potential.

Do not loop level L signal wires around level H, level MP, or HP wires.

Section 4.2.5 RF Interference

To prevent radio frequency (RF) interference, care should be taken in routing power cables in the vicinity of radio-controlled devices.

Section 4.2.6 Suppression

Unless specifically noted otherwise, suppression (for example, a snubber) is required on all inductive devices controlled by an output. This suppression minimizes noise and prevents damage caused by electrical surges.

Section 4.3 Recommended Lubrication of Pins and Sockets Prior to Installation

Beginning in January of 1999, GE implemented the addition of a lubricant to all connections using pins and sockets on EV100/EV200 and Gen II products. Any connection made by GE to the A, B, X, Y, or Z plugs will have the lubricant NYE

760G added to prevent fretting of these connections during vehicle operation.

Fretting occurs during microscopic movement at the contact points of the connection. This movement exposes the base metal of the connector pin which, when oxygen is present, allows oxidation to occur. Sufficient build up of the oxidation can cause intermittent contact and intermittent vehicle operation. This can occur at any similar type of connection, whether at the control or in any associated vehicle wiring, and the resultant intermittent contact can provide the same fault indication as actual component failure.

The addition of the NYE 760G lubricant will prevent the oxidation process by eliminating the access of oxygen to the contact point. GE recommends the addition of this lubricant to the 12 pin and 23 pin plugs of all new Gen II controls at the time of their installation into a vehicle

When servicing existing vehicles exhibiting symptoms of intermittent mis-operation or shutdown by the GE control, GE recommends the addition of this lubricant to all 12 and 23 pin plugs, after proper cleaning of the connectors, as a preventative measure to insure fretting is not an issue before GE control replacement.

Section 4.4 General Troubleshooting Instructions

Trouble-shooting the SX family of controls should be quick and easy when following the instructions outlined in the following status code instruction sheets.

If mis-operation of the vehicle occurs, a status code will be displayed on the Dash Display (for vehicles equipped with a Dash Display) or made available by plugging a Handset into the plug "Y" location, and then reading the status code.

With the status code number, follow the procedures outlined in the status code instruction sheets to determine the problem.

Important Note: Due to the interaction of the logic card with all vehicle functions, almost any status code or control fault could be caused by the logic card. After all other status code procedures have been followed and no problem is found, the controller should then be replaced as the last option to correct the problem.

The same device designations have been maintained on different controls but the wire numbers may vary. Refer to the elementary and wiring diagrams for your specific control. The wire numbers shown on the elementary diagram will have identical numbers on the corresponding wiring diagrams for a specific vehicle, but these numbers may be different from the numbers referenced in this publication.

WARNING: Before trouble-shooting, jack up the drive wheels, disconnect the battery and discharge the capacitors. Reconnect the battery as needed for specific checks. Capacitors should be discharged by connecting a 200 ohm 2 watt resistor between the positive and negative terminals on the control panel.

Check resistance on R x 1000 scale from frame to power and control terminals. A resistance of less than 20,000 ohms can cause misleading symptoms. Resistance less than 1000 ohms should be corrected first.

Before proceeding, visually check for loose wiring, mis-aligned linkage to the accelerator switch, signs of overheating of components, etc.

Tools and test equipment required are: clip leads, volt-ohm meter (20,000 ohms per volt) and basic hand tools.

Section 4.5 Traction Control Status Codes

TRACTION STATUS CODE	DESCRIPTION OF STATUS	CAUSE OF STATUS INDICATION
NONE	Segments do not illuminate on the Dash Display and/or the Handset.	No input voltage to the control card or the display unit.
MEMORY RECALL NO	CORRECTIVE ACTIONS	<u>TROUBLE-SHOOTING DIAGRAM</u>
Circuits valid for Traction Controller	<p><u>SYMPTOM</u> Display screen on Dash Display and/or Handset is blank.</p> <p><u>POSSIBLE CAUSE</u> Positive or negative control voltage is not present.</p> <ul style="list-style-type: none"> • Insure that the key switch is closed and voltage is present between P1 & battery negative (Power Terminal "NEG"). Also check for voltage between P2 and control negative. <p>Open circuit between control card Plug Y & the Dash Display or Handset.</p> <ul style="list-style-type: none"> • Check for an open circuit or loose connection going from the "Y" plug and the Dash Display or Handset. <p>Defective Dash Display or Handset.</p> <ul style="list-style-type: none"> • Replace Dash Display or Handset. 	

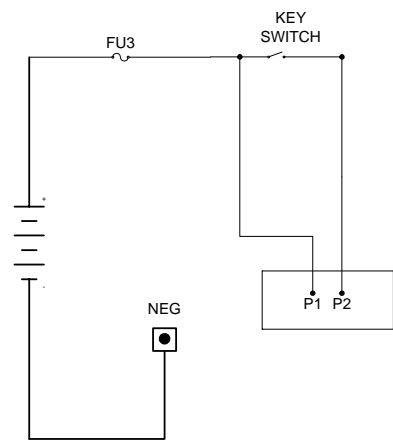

TRACTION STATUS CODE	DESCRIPTION OF STATUS	CAUSE OF STATUS INDICATION
-01	No seat switch or deadman switch input (no voltage to P6).	This status code will be displayed when P6 is less than 50% battery volts.
MEMORY RECALL NO	CORRECTIVE ACTIONS	<u>TROUBLE-SHOOTING DIAGRAM</u>
Circuits valid for Traction Controller	<p><u>SYMPTOM</u> Control will not operate.</p> <p><u>POSSIBLE CAUSE</u> Mis-adjusted or defective seat or deadman switch.</p> <ul style="list-style-type: none"> • Check to see that the seat switch closes properly. <p>Open circuit between battery positive and P6.</p> <ul style="list-style-type: none"> • Check for loose connections or broken wires: <ul style="list-style-type: none"> – Between the seat switch and P6 – Between the key switch and the battery positive side of the seat switch. – Between the seat switch and P2. • On vehicles without a seat/deadman switch, check for a loose connection or broken wire from P2 and/or P6. 	

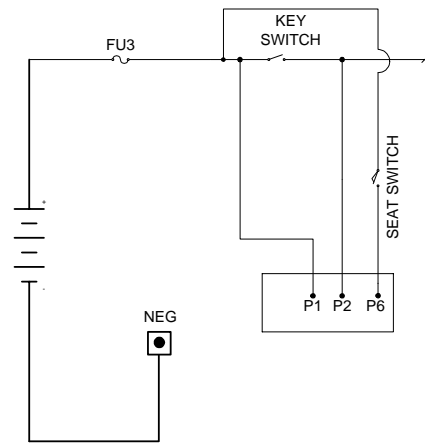

TRACTION STATUS CODE	DESCRIPTION OF STATUS	CAUSE OF STATUS INDICATION
-02	Forward directional switch is closed on initial power up.	This status code will be displayed when P4 is greater than 60% of battery voltage at initial key switch on.
MEMORY RECALL NO	CORRECTIVE ACTIONS	TROUBLE-SHOOTING DIAGRAM
Circuits valid for Traction Controller	<p>SYMPTOM Control will not operate because of Static Return to Off (SRO) lock out.</p> <p>POSSIBLE CAUSE Forward directional switch is closed on initial start up (i.e. closure of battery, key switch or seat switch).</p> <ul style="list-style-type: none"> Return directional switch lever to neutral and then return lever to forward position. <p>Forward directional switch is welded closed or mis-adjusted to be held closed.</p> <ul style="list-style-type: none"> Replace or adjust directional switch to insure that it opens when the directional switch is returned to neutral. <p>Short circuit between P3 and P4.</p> <ul style="list-style-type: none"> Disconnect the wire from P4 and check for a short circuit between P3 and the wire that was connected to P4. <p>Defective control.</p> <ul style="list-style-type: none"> Replace the controller unit. 	

TRACTION STATUS CODE	DESCRIPTION OF STATUS	CAUSE OF STATUS INDICATION
-03	Reverse directional switch is closed on initial power up.	This status code will be displayed when P5 is greater than 60% of battery voltage at initial key switch on.
MEMORY RECALL NO	CORRECTIVE ACTIONS	TROUBLE-SHOOTING DIAGRAM
Circuits valid for Traction Controller	<p>SYMPTOM Control will not operate because of Static Return to Off (SRO) lock out.</p> <p>POSSIBLE CAUSE Reverse directional switch is closed on initial start up (i.e. closure of battery, key switch or seat/deadman switch).</p> <ul style="list-style-type: none"> Return directional switch lever to neutral and then return lever to reverse position. <p>Reverse directional switch is welded closed or mis-adjusted to be held closed.</p> <ul style="list-style-type: none"> Replace or adjust directional switch to insure that it opens when the directional switch is returned to neutral. <p>Short circuit between P3 and P5.</p> <ul style="list-style-type: none"> Disconnect the wire from P5 and check for a short circuit between P3 and the wire that was connected to P5. <p>Defective control. Replace the controller unit.</p>	

TRACTION STATUS CODE	DESCRIPTION OF STATUS	CAUSE OF STATUS INDICATION
-04	Brake pedal depressed while motoring	This status code will be displayed when P13 is .25 volts greater than the low learn point and 5 seconds have timed out in motoring.
MEMORY RECALL NO	CORRECTIVE ACTIONS	TROUBLE-SHOOTING DIAGRAM
Circuits valid for Traction Controller	<p>SYMPTOM Control will not operate.</p> <p>POSSIBLE CAUSE Defective brake potentiometer.</p> <p>Brake pedal depressed while trying to motor.</p>	

TRACTION STATUS CODE	DESCRIPTION OF STATUS	CAUSE OF STATUS INDICATION
-05	Start switch fails to close.	This status code will be displayed when the accelerator (P7) is calling for greater than 40% on-time, while the start switch (P3) is less than 60% of battery volts.
MEMORY RECALL NO	CORRECTIVE ACTIONS	TROUBLE-SHOOTING DIAGRAM
Circuits valid for Traction Controller	<p>SYMPTOM Control will not operate.</p> <p>POSSIBLE CAUSE Defective start switch circuit.</p> <ul style="list-style-type: none"> • Check start switch to insure closure when accelerator is depressed. • Check for open circuit or loose connections in wiring from brake switch to start switch and from P3 to start switch. <p>Defective accelerator switch.</p> <ul style="list-style-type: none"> • Check accelerator switch potentiometer for proper operation and ohmic value. 	

TRACTION STATUS CODE	DESCRIPTION OF STATUS	CAUSE OF STATUS INDICATION
-06	Accelerator depressed with no direction selected.	This status code will be displayed while P4 and P5 are less than 60% of battery volts, and the accelerator (P7) is calling for greater than 40% on-time.
MEMORY RECALL NO	CORRECTIVE ACTIONS	TROUBLE-SHOOTING DIAGRAM
Circuits valid for Traction Controller	<p>SYMPTOM Control will not operate.</p> <p>POSSIBLE CAUSE Accelerator pedal is depressed before closing forward or reverse directional switch.</p> <ul style="list-style-type: none"> Status code will disappear when directional switch is closed or when accelerator pedal is released. <p>Defective directional switch</p> <ul style="list-style-type: none"> Check forward or reverse switch to insure closure when direction is selected. <p>Open circuit between directional switch(es) and battery positive or between directional switch(es) and P4 or P5.</p> <ul style="list-style-type: none"> Check all control wires and connections shown in Trouble Shooting Diagram. 	

TRACTION STATUS CODE	DESCRIPTION OF STATUS	CAUSE OF STATUS INDICATION
-08	Accelerator input voltage too low on power up after initial key switch closure.	This status code will be displayed when the accelerator input voltage at P7 is calling for greater than 20% on-time at start-up.
MEMORY RECALL NO	CORRECTIVE ACTIONS	TROUBLE-SHOOTING DIAGRAM
Circuits valid for Traction Controller	<p>SYMPTOM Control will not operate.</p> <p>POSSIBLE CAUSE Accelerator input mis-adjusted or defective.</p> <ul style="list-style-type: none"> Input voltage at P7 should be less than 20% of learned span resistance. Adjust or replace accelerator unit to insure that the voltage at P7 is correct. Open wire between potentiometer negative and P8 <p>Defective Card</p> <ul style="list-style-type: none"> Replace controller unit. 	

TRACTION STATUS CODE	DESCRIPTION OF STATUS	CAUSE OF STATUS INDICATION
-09	Both the forward and reverse directional switches are closed at the same time.	This status code will be displayed when P4 and P5 are greater than 60% of battery volts at the same time.
MEMORY RECALL NO	CORRECTIVE ACTIONS	TROUBLE-SHOOTING DIAGRAM
Circuits valid for Traction Controller	<p>SYMPTOM Control will not operate.</p> <p>POSSIBLE CAUSE Forward or reverse directional switch welded closed or mis-adjusted to be held closed.</p> <ul style="list-style-type: none"> Replace or adjust directional switches to insure that they open when directional switch is returned to neutral. <p>Short circuit between battery positive and P4 and/or P5.</p> <ul style="list-style-type: none"> Disconnect wires from P4 and P5 and check wire for short circuit to positive side of directional switch. <p>Defective Control</p> <ul style="list-style-type: none"> Disconnect wires and measure voltage at P4 and P5. Voltage should be less than 60% of battery volts. 	<p>The diagram shows a circuit starting from a KEY SWITCH. A line goes from the key switch to a terminal labeled P1. From P1, a line goes to a lamp (L). From the lamp, a line goes to terminal P17. From P17, a line goes to terminal P2. From P2, a line goes to terminal P6. From P6, a line goes to terminal P3. From P3, a line goes to terminal P4. From P4, a line goes to terminal P5. There are also four switches labeled SEAT SW., START SW., FORWARD SW., and REVERSE SW. connected to the circuit between P2 and P5.</p>

TRACTION STATUS CODE	DESCRIPTION OF STATUS	CAUSE OF STATUS INDICATION
-10	Steer angle potentiometer voltage is too high.	This status code will be displayed when P12 is greater than 4.0 volts.
MEMORY RECALL NO	CORRECTIVE ACTIONS	TROUBLE-SHOOTING DIAGRAM
Circuits valid for Traction Controller	<p>SYMPTOM Control will not operate.</p> <p>POSSIBLE CAUSE Steer angle potentiometer input mis-adjusted or defective. Loose or missing connections at P19, P12 or P20.</p> <ul style="list-style-type: none"> Input voltage at P12 should be less than 4.0 volts at all times. Insure that the adjustment of the steer potentiometer is in accordance with Section 9 of this instruction. <p>Defective control.</p> <ul style="list-style-type: none"> Replace controller unit. 	<p>The diagram shows a STEER ANGLE POT (potentiometer) with three terminals labeled P19, P12, and P20. P19 is on the left, P12 is in the middle, and P20 is on the right. The potentiometer is shown as a circular component with a wiper arm.</p>

TRACTION STATUS CODE	DESCRIPTION OF STATUS	CAUSE OF STATUS INDICATION
-11	Start switch closed on power up after initial key switch closure.	This status code will be displayed when P3 is greater than 60% of battery voltage when the key switch is closed.
MEMORY RECALL NO	CORRECTIVE ACTIONS	TROUBLE-SHOOTING DIAGRAM
Circuits valid for Traction Controller	<p>SYMPTOM Control will not operate.</p> <p>POSSIBLE CAUSE Start switch input mis-adjusted or defective.</p> <ul style="list-style-type: none"> Input voltage at P3 should be less than 60% of battery volts at key switch closing. Adjust or replace accelerator unit to insure that the voltage at P3 is less than 60% of battery volts before closing the start switch. <p>Short circuit between battery positive and P3 in start switch input circuit.</p> <ul style="list-style-type: none"> Disconnect wire from P3. Check for short circuit from this wire to battery positive. Resistance should be greater than 4.7K ohms. <p>Defective control.</p> <ul style="list-style-type: none"> Disconnect wire from P3. Measure voltage from P3 to negative. Voltage should be zero, if not, replace control. 	

TRACTION STATUS CODE	DESCRIPTION OF STATUS	CAUSE OF STATUS INDICATION
-12	Steer angle potentiometer voltage is too low.	This status code will be displayed when P12 is less than .30 volts.
MEMORY RECALL NO	CORRECTIVE ACTIONS	TROUBLE-SHOOTING DIAGRAM
Circuits valid for Traction Controller	<p>SYMPTOM Control will not operate.</p> <p>POSSIBLE CAUSE Steer angle potentiometer input mis-adjusted or defective. Loose or missing connections at P19, P12 or P20.</p> <ul style="list-style-type: none"> Input voltage at P12 should be greater than .30 volts at all times. Insure that the adjustment of the steer potentiometer is in accordance with Section 9 of this instruction. <p>Defective control.</p> <ul style="list-style-type: none"> Replace controller unit. 	

TRACTION STATUS CODE	DESCRIPTION OF STATUS	CAUSE OF STATUS INDICATION
-14	The brake switch is open with the brake pot voltage at some percentage greater than the brake low learn setting (the applicable percentage is determined by function setting).	This status code will be displayed when the brake switch is open and the brake pot voltage is some percentage (defined by function setting) greater than the brake low learn setting.
MEMORY RECALL NO	CORRECTIVE ACTIONS	<u>TROUBLE-SHOOTING DIAGRAM</u>
Circuits valid for Traction Controller	<p><u>SYMPTOM</u> Flashing "-14" status code on the dash display</p> <p><u>POSSIBLE CAUSE</u> Brake pot is mis-adjusted.</p> <p>Truck brake pads are excessively worn.</p> <p>Brake switch is mis-adjusted.</p>	

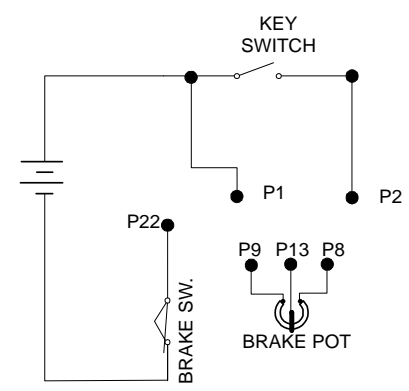

TRACTION STATUS CODE	DESCRIPTION OF STATUS	CAUSE OF STATUS INDICATION
-15	Battery voltage is too low or control card is mis-adjusted.	This status code will be displayed when the battery volts are less than 1.95 volts per cell at initial key switch on. See table below.
MEMORY RECALL NO	CORRECTIVE ACTIONS	<u>TROUBLE-SHOOTING DIAGRAM</u>
Circuits valid for Traction Controller	<p><u>SYMPTOM</u> Control will not operate.</p> <p><u>POSSIBLE CAUSE</u> Discharged battery</p> <ul style="list-style-type: none"> Check battery for proper open circuit voltage as shown in "Trouble Shooting Diagram", charge battery, if required. <p>Defective battery</p> <ul style="list-style-type: none"> Check each battery cell for proper voltage (greater than 1.95 volts at cell). Replace or repair battery. <p>Incorrect control card adjustment.</p> <ul style="list-style-type: none"> Check Function 15 for proper adjustment for battery being used. See Handset instruction sheet for details. Adjust to proper settings. <p>Check "minimum" battery volts at P1 and NEG.</p>	

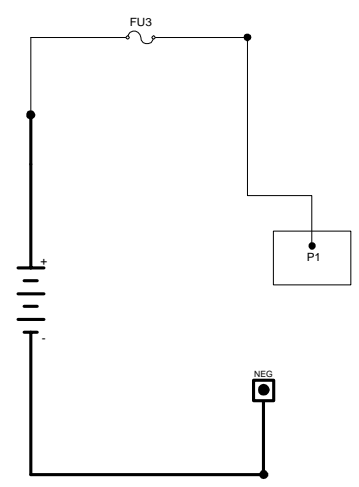

NOMINAL BATTERY VOLTAGE	MINIMUM LIMIT VOLTS AT 1.95 VDC PER CELL
24	23.4
36	35.1
48	46.8
72	70.2
80	78.0

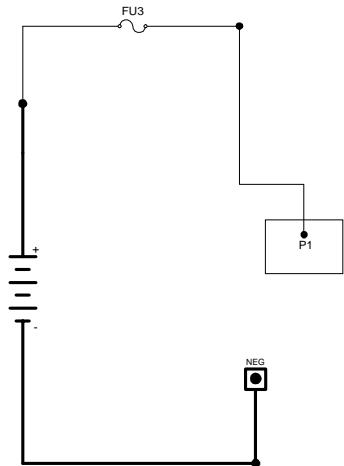
TRACTION STATUS CODE	DESCRIPTION OF STATUS	CAUSE OF STATUS INDICATION												
-16	Battery voltage is too high or control card is mis-adjusted.	This status code will be displayed when the battery volts are greater than 2.4 volts per cell at initial key switch on. See table below.												
MEMORY RECALL NO	CORRECTIVE ACTIONS	TROUBLE-SHOOTING DIAGRAM												
Circuits valid for Traction Controller	<p>SYMPTOM Control will not operate.</p> <p>POSSIBLE CAUSE Incorrect control card adjustment</p> <ul style="list-style-type: none"> Check Function 15 for proper adjustment for battery in use. See Handset instructions for details. Adjust to proper setting. <p>Battery over charged or incorrect battery used.</p> <ul style="list-style-type: none"> Check battery for proper open circuit voltage per table at right. If voltage is excessive, check battery charger for proper output voltage. <p>Check "maximum" battery volts at P1 and NEG.</p>	 <table border="1" data-bbox="1258 525 1485 766"> <thead> <tr> <th>NOMINAL BATTERY VOLTAGE</th> <th>MAXIMUM LIMIT VOLTS AT 2.40 VDC PER CELL</th> </tr> </thead> <tbody> <tr> <td>24</td> <td>28.8</td> </tr> <tr> <td>36</td> <td>43.2</td> </tr> <tr> <td>48</td> <td>57.6</td> </tr> <tr> <td>72</td> <td>86.4</td> </tr> <tr> <td>80</td> <td>96.0</td> </tr> </tbody> </table>	NOMINAL BATTERY VOLTAGE	MAXIMUM LIMIT VOLTS AT 2.40 VDC PER CELL	24	28.8	36	43.2	48	57.6	72	86.4	80	96.0
NOMINAL BATTERY VOLTAGE	MAXIMUM LIMIT VOLTS AT 2.40 VDC PER CELL													
24	28.8													
36	43.2													
48	57.6													
72	86.4													
80	96.0													

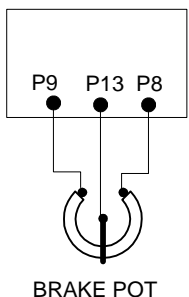
TRACTION STATUS CODE	DESCRIPTION OF STATUS	CAUSE OF STATUS INDICATION
-17	Brake pot is out of range.	This status code will be displayed when the brake pot voltage is less than 0.5 volts or greater than 4.0 volts.
MEMORY RECALL YES	CORRECTIVE ACTIONS	TROUBLE-SHOOTING DIAGRAM
Circuits valid for Traction Controller	<p>SYMPTOM Control will not auto regen.</p> <p>POSSIBLE CAUSE Defective brake pot.</p> <p>The 5V supply wire to the brake pot has become disconnected.</p> <p>The negative wire to the brake pot has become disconnected.</p> <p>The brake pot wiper connection has been lost.</p> <p>The control is defective.</p>	 <p style="text-align: center;">BRAKE POT</p>

TRACTION STATUS CODE	DESCRIPTION OF STATUS	CAUSE OF STATUS INDICATION
-18	Battery voltage is dropping too low during motoring.	This status code will be displayed when the battery volts drops below 16 volts during motoring.
MEMORY RECALL YES	CORRECTIVE ACTIONS	<u>TROUBLE-SHOOTING DIAGRAM</u>
Circuits valid for Traction Controller	<p><u>SYMPTOM</u> Control will not operate.</p> <p><u>POSSIBLE CAUSE</u> Battery is at low state of charge.</p> <ul style="list-style-type: none"> • Charge battery. <p>Control is defective.</p> <ul style="list-style-type: none"> • Replace control. 	

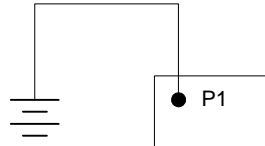

TRACTION STATUS CODE	DESCRIPTION OF STATUS	CAUSE OF STATUS INDICATION
-21	Accelerator volts is too high.	This status code will be displayed when the accelerator voltage is greater than 4.5 volts.
MEMORY RECALL NO	CORRECTIVE ACTIONS	<u>TROUBLE-SHOOTING DIAGRAM</u>
Circuits valid for Traction Controller	<p><u>SYMPTOM</u> Control will not operate.</p> <p><u>POSSIBLE CAUSE</u> Missing accelerator wiper input.</p> <ul style="list-style-type: none"> • Verify connection between P7 of both (master and slave) controls and the accelerator wiper. <p>Missing accelerator negative input.</p> <ul style="list-style-type: none"> • Verify accelerator wiring. 	

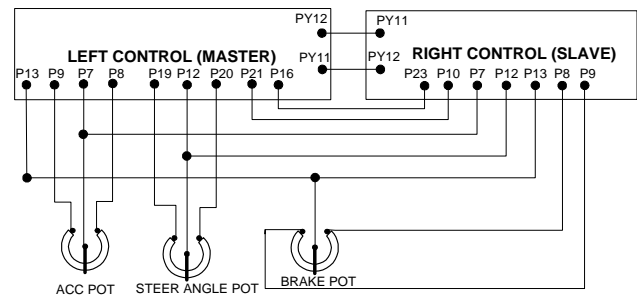

TRACTION STATUS CODE	DESCRIPTION OF STATUS	CAUSE OF STATUS INDICATION
-23	Motor field current is high on start up in the reverse direction.	This status code will be displayed when the current draw in the motor field is too high at start up in the reverse direction.
MEMORY RECALL NO	CORRECTIVE ACTIONS	<u>TROUBLE-SHOOTING DIAGRAM</u>
Circuits valid for Traction Controller	<p><u>SYMPTOM</u> Control will not operate.</p> <p><u>POSSIBLE CAUSE</u> Defective control.</p> <ul style="list-style-type: none"> • Replace controller unit. 	NO GRAPHIC FOR THIS STATUS CODE

TRACTION STATUS CODE	DESCRIPTION OF STATUS	CAUSE OF STATUS INDICATION
-24	Motor field current is high on start up in the forward direction.	This status code will be displayed when the current draw in the motor field is too high at start up in the forward direction.
MEMORY RECALL NO	CORRECTIVE ACTIONS	<u>TROUBLE-SHOOTING DIAGRAM</u>
Circuits valid for Traction Controller	<p><u>SYMPTOM</u> Control will not operate.</p> <p><u>POSSIBLE CAUSE</u> Defective control.</p> <ul style="list-style-type: none"> • Replace controller unit. 	NO GRAPHIC FOR THIS STATUS CODE

TRACTION STATUS CODE	DESCRIPTION OF STATUS	CAUSE OF STATUS INDICATION
-25	Armature current compensation calibration fault.	This status code will be displayed when the voltage at P16 of the master control is less than 2.4 V or greater than 2.6V at start up.
MEMORY RECALL NO	CORRECTIVE ACTIONS	TROUBLE-SHOOTING DIAGRAM
Circuits valid for Traction Controller	<p>SYMPTOM Control will not operate.</p> <p>POSSIBLE CAUSE Missing connection between master and slave controls.</p> <ul style="list-style-type: none"> Verify connection between P16 of the master control and P23 of the slave control <p>Defective control.</p> <ul style="list-style-type: none"> Replace controller unit. 	

TRACTION STATUS CODE	DESCRIPTION OF STATUS	CAUSE OF STATUS INDICATION
-27	Power supply is less than 10 Volts DC.	This status code will be displayed when the power supply is less than 10 volts.
MEMORY RECALL YES	CORRECTIVE ACTIONS	TROUBLE-SHOOTING DIAGRAM
Circuits valid for Traction Controller	<p>SYMPTOM Line contactor opens and closes, then can only be closed by opening and closing the key switch.</p> <p>POSSIBLE CAUSE Discharged Battery</p> <ul style="list-style-type: none"> Check battery to insure proper state of charge. Voltage may be dropping below 10 Volts DC under load. <p>Loose connection at P1.</p> <ul style="list-style-type: none"> Insure that the wire connection at P1 is tight. <p>Defective control.</p> <ul style="list-style-type: none"> Replace controller unit. 	

TRACTION STATUS CODE	DESCRIPTION OF STATUS	CAUSE OF STATUS INDICATION
-28	Motor field current is too high during the run mode.	This status code will be displayed when the current in the motor field is sustained above a preset limit for longer than 70 seconds.
MEMORY RECALL NO	CORRECTIVE ACTIONS	<u>TROUBLE-SHOOTING DIAGRAM</u>
Circuits valid for Traction Controller	<p><u>SYMPTOM</u> Control will not operate.</p> <p><u>POSSIBLE CAUSE</u> Continued operation of vehicle in high motor current condition.</p> <ul style="list-style-type: none"> Operate vehicle at lower motor current condition 70 seconds. <p>Function 7 is mis-adjusted to allow higher than normal motor field current.</p> <ul style="list-style-type: none"> Adjust function per OEM instructions. 	NO GRAPHIC FOR THIS STATUS CODE

TRACTION STATUS CODE	DESCRIPTION OF STATUS	CAUSE OF STATUS INDICATION
-30	"Slave" control has had "Master" control card type selected.	This status code will be displayed when the control in the slave position has been programmed as a master.
MEMORY RECALL NO	CORRECTIVE ACTIONS	<u>TROUBLE-SHOOTING DIAGRAM</u>
Circuits valid for Traction Controller	<p><u>SYMPTOM</u> Control will not operate.</p> <p><u>POSSIBLE CAUSE</u> Control installed in the slave position has been set up as a master control.</p> <ul style="list-style-type: none"> Check Function 17 setting. <p>Controller unit is defective.</p> <ul style="list-style-type: none"> Replace controller unit. 	<p>The diagram shows a KEY SWITCH connected to a power source (battery symbol). The switch has two main output lines. One line goes to a terminal labeled 'P1' on a box labeled 'MASTER CONTROL'. The other line goes to a terminal labeled 'P1' on a box labeled 'SLAVE CONTROL'. A second line from the switch goes to a terminal labeled 'P21' on the 'SLAVE CONTROL' box. This wiring indicates that the slave control is being treated as a master control.</p>

TRACTION STATUS CODE	DESCRIPTION OF STATUS	CAUSE OF STATUS INDICATION
-31	The first byte of data sent from the master to the slave "timed out".	This status code will be displayed when the slave control is expecting to receive the first byte of data and does not.
MEMORY RECALL NO	CORRECTIVE ACTIONS	<u>TROUBLE-SHOOTING DIAGRAM</u>
Circuits valid for Traction Controller	<p><u>SYMPTOM</u> Control does not operate.</p> <p><u>POSSIBLE CAUSE</u> Wiring has become disconnected between the master and slave control.</p> <ul style="list-style-type: none"> • PY11 in the slave control is not connected. • PY12 in the master control is not connected. • PY12 in the slave control is not connected. • PY11 in the master control is not connected. <p>Defective controller unit.</p> <ul style="list-style-type: none"> • Replace controller unit. 	<p style="text-align: center;">MASTER CONTROL SLAVE CONTROL</p>

TRACTION STATUS CODE	DESCRIPTION OF STATUS	CAUSE OF STATUS INDICATION
-32	This status code is generated when there is an RS232 transmission error.	This status code will be displayed when either the master or the slave control does not receive the expected data.
MEMORY RECALL NO	CORRECTIVE ACTIONS	<u>TROUBLE-SHOOTING DIAGRAM</u>
Circuits valid for Traction Controller	<p><u>SYMPTOM</u> Control will not operate.</p> <p><u>POSSIBLE CAUSE</u> Defective controller unit.</p> <ul style="list-style-type: none"> • Replace controller unit. 	<p>NO GRAPHIC FOR THIS STATUS CODE</p>

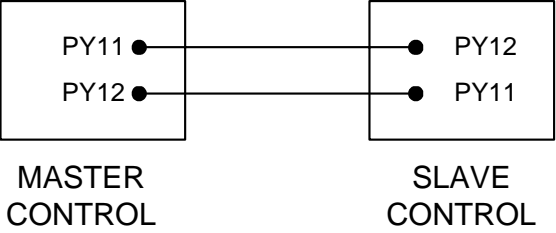
TRACTION STATUS CODE	DESCRIPTION OF STATUS	CAUSE OF STATUS INDICATION
-33	Either the master or the slave control "timed out" while waiting for data after the initial byte.	This status code will be displayed when either the master or slave control did not receive any data.
MEMORY RECALL NO	CORRECTIVE ACTIONS	TROUBLE-SHOOTING DIAGRAM
Circuits valid for Traction Controller	<p>SYMPTOM Control will not operate.</p> <p>POSSIBLE CAUSE Loss of the RS232 connection between the master and slave controls.</p> <ul style="list-style-type: none"> • PY11 in the slave control is not connected. • PY12 in the master control is not connected. • PY12 in the slave control is not connected. • PY11 in the master control is not connected. <p>One control is displaying a different fault and did not transmit data.</p> <ul style="list-style-type: none"> • Check other control for displayed status codes. <p>Defective controller unit.</p> <ul style="list-style-type: none"> • Replace control. 	 <p>The diagram shows two boxes representing the Master Control and Slave Control. The Master Control box has two terminals labeled PY11 and PY12. The Slave Control box has two terminals labeled PY12 and PY11. A horizontal line connects the PY11 terminal of the Master Control to the PY12 terminal of the Slave Control. Another horizontal line connects the PY12 terminal of the Master Control to the PY11 terminal of the Slave Control.</p>

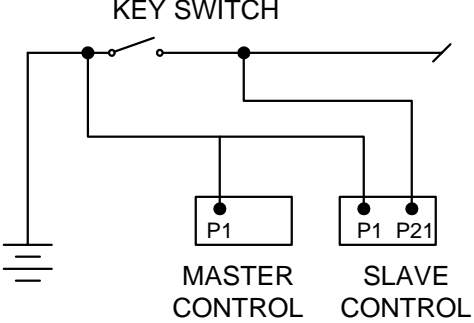
TRACTION STATUS CODE	DESCRIPTION OF STATUS	CAUSE OF STATUS INDICATION
-34	"Master" control has had "slave" control card type selected.	This status code will be displayed when the control in the master position has been programmed as a slave.
MEMORY RECALL NO	CORRECTIVE ACTIONS	TROUBLE-SHOOTING DIAGRAM
Circuits valid for Traction Controller	<p>SYMPTOM Control will not operate.</p> <p>POSSIBLE CAUSE Control installed in the master position has been set up as a slave control.</p> <ul style="list-style-type: none"> • Check Function 17 setting. <p>P21 in the slave control is not at battery volts when the key switch is turned on.</p> <ul style="list-style-type: none"> • Verify the connection between P21 and the key switch. <p>Controller unit is defective.</p> <ul style="list-style-type: none"> • Replace control. 	 <p>The diagram shows a circuit starting from a battery symbol on the left. A line goes up to a KEY SWITCH. From the switch, a line goes right and then down to a terminal labeled P1 on a box labeled MASTER CONTROL. Another line goes down from the switch to a terminal labeled P1 on a box labeled SLAVE CONTROL. A third line goes down from the switch to a terminal labeled P21 on the SLAVE CONTROL box.</p>

TRACTION STATUS CODE	DESCRIPTION OF STATUS	CAUSE OF STATUS INDICATION
-35	The first byte of data sent to the "master" control has timed out.	This status code will be displayed when the master control does not receive the first byte of data when expected.
MEMORY RECALL NO	CORRECTIVE ACTIONS	<u>TROUBLE-SHOOTING DIAGRAM</u>
Circuits valid for Traction Controller	<p><u>SYMPTOM</u> Control does not operate.</p> <p><u>POSSIBLE CAUSE</u> Loss of the RS232 connection between the master and slave controls.</p> <ul style="list-style-type: none"> • PY11 in the slave control is not connected. • PY12 in the master control is not connected. • PY12 in the slave control is not connected. • PY11 in the master control is not connected. <p>P21 in the slave control is not at battery volts when the key switch is turned on.</p> <ul style="list-style-type: none"> • Verify the connection between P21 and the key switch. <p>Controller unit is defective. Replace control.</p>	

TRACTION STATUS CODE	DESCRIPTION OF STATUS	CAUSE OF STATUS INDICATION
-36	The function setting did not transfer from the master control to the slave control.	This status code will be displayed when the function settings of the master control do not transfer to the slave control.
MEMORY RECALL NO	CORRECTIVE ACTIONS	<u>TROUBLE-SHOOTING DIAGRAM</u>
Circuits valid for Traction Controller	<p><u>SYMPTOM</u> Control does not operate.</p> <p><u>POSSIBLE CAUSE</u> Defective controller unit.</p> <ul style="list-style-type: none"> • Replace control. 	<p style="text-align: center;">NO GRAPHIC FOR THIS STATUS CODE</p>

TRACTION STATUS CODE	DESCRIPTION OF STATUS	CAUSE OF STATUS INDICATION
-37	Indicates that the user needs to cycle the key switch after exiting the handset routine, if the key switch is still on.	This status code will be displayed when the user exits the handset routine and the key switch is still on.
MEMORY RECALL NO	CORRECTIVE ACTIONS	<u>TROUBLE-SHOOTING DIAGRAM</u>
Circuits valid for Traction Controller	<p><u>SYMPTOM</u> Controller will not operate.</p> <p><u>POSSIBLE CAUSE</u> Key switch is on and the user has just exited the handset routine.</p> <ul style="list-style-type: none"> • Cycle the key switch. 	NO GRAPHIC FOR THIS STATUS CODE

TRACTION STATUS CODE	DESCRIPTION OF STATUS	CAUSE OF STATUS INDICATION
-40	A -41 status code exists in the opposite control.	This status code will be displayed in the master control when the slave control is in thermal cutback, and displayed in the slave control when the master control is in thermal cutback.
MEMORY RECALL NO	CORRECTIVE ACTIONS	<u>TROUBLE-SHOOTING DIAGRAM</u>
Circuits valid for Traction Controller	<p><u>SYMPTOM</u> The controls only permit reduced truck performance.</p> <p><u>POSSIBLE CAUSE</u> A -41 fault code is being displayed in the opposite control.</p> <ul style="list-style-type: none"> • Allow the controls to cool to ambient temperature so that the status code is resolved. • If status code fails to disappear when both controls return to ambient temperature, a defective controller unit is possible. 	NO GRAPHIC FOR THIS STATUS CODE

TRACTION STATUS CODE	DESCRIPTION OF STATUS	CAUSE OF STATUS INDICATION
-41	Open thermal protector (TP) or transistor over temperature.	This status code will be displayed when the voltage at the thermal protector is too high.
MEMORY RECALL NO	CORRECTIVE ACTIONS	<u>TROUBLE-SHOOTING DIAGRAM</u>
Circuits valid for Traction Controller	<p><u>SYMPTOM</u> Reduced or no power to traction motor in control range.</p> <p><u>POSSIBLE CAUSE</u> Control is in thermal cut-back.</p> <ul style="list-style-type: none"> • Allow control to cool, status code should disappear. <p>Defective control.</p> <ul style="list-style-type: none"> • Replace controller unit. 	NO GRAPHIC FOR THIS STATUS CODE

TRACTION STATUS CODE	DESCRIPTION OF STATUS	CAUSE OF STATUS INDICATION
-42	Motor armature offset voltage is too high.	This status code will be displayed when the voltage at the current sensor input is greater than 2.6 volts with no current flowing in the motor circuit.
MEMORY RECALL NO	CORRECTIVE ACTIONS	<u>TROUBLE-SHOOTING DIAGRAM</u>
Circuits valid for Traction Controller	<p><u>SYMPTOM</u> Control will not operate.</p> <p><u>POSSIBLE CAUSE</u> Defective control.</p> <ul style="list-style-type: none"> • Replace controller unit. 	NO GRAPHIC FOR THIS STATUS CODE

TRACTION STATUS CODE	DESCRIPTION OF STATUS	CAUSE OF STATUS INDICATION
-43	Motor armature offset voltage is too low.	This status code will be displayed when the voltage at the current sensor input is less than 2.4 volts with no current flowing in the motor circuit.
MEMORY RECALL NO	CORRECTIVE ACTIONS	<u>TROUBLE-SHOOTING DIAGRAM</u>
Circuits valid for Traction Controller	<p><u>SYMPTOM</u> Control will not operate.</p> <p><u>POSSIBLE CAUSE</u> Defective control.</p> <ul style="list-style-type: none"> • Replace controller unit. 	NO GRAPHIC FOR THIS STATUS CODE

TRACTION STATUS CODE	DESCRIPTION OF STATUS	CAUSE OF STATUS INDICATION
-44	Armature transistor did not turn off properly.	This status code will be displayed when, during control operation, the armature transistor fails to turn off. This will result in a PMT condition.
MEMORY RECALL YES	CORRECTIVE ACTIONS	<u>TROUBLE-SHOOTING DIAGRAM</u>
Circuits valid for Traction Controller	<p><u>SYMPTOM</u> Line contactor opens and closes, then can only be closed by opening and closing the key switch.</p> <p><u>POSSIBLE CAUSE</u> Defective control.</p> <ul style="list-style-type: none"> • Replace controller unit. 	

TRACTION STATUS CODE	DESCRIPTION OF STATUS	CAUSE OF STATUS INDICATION
-45	Armature transistor did not turn on properly.	This status code will be displayed when, during control operation, the armature transistor fails to turn on properly. This will result in a PMT condition.
MEMORY RECALL YES	CORRECTIVE ACTIONS	TROUBLE-SHOOTING DIAGRAM
Circuits valid for Traction Controller	<p>SYMPTOM Line contactor open and close, then can only be closed by opening and closing the key switch.</p> <p>POSSIBLE CAUSE Defective control.</p> <ul style="list-style-type: none"> • Replace controller unit. 	

TRACTION STATUS CODE	DESCRIPTION OF STATUS	CAUSE OF STATUS INDICATION
-46	"Look Ahead" test for A2 volts less than 12% of battery volts.	This status code will be displayed when the voltage at A2 is less than 12% of battery volts.
MEMORY RECALL NO	CORRECTIVE ACTIONS	TROUBLE-SHOOTING DIAGRAM
Circuits valid for Traction Controller	<p>SYMPTOM Line contactor will not pick up.</p> <p>POSSIBLE CAUSE Check for short circuit from the motor armature to the frame of the vehicle.</p> <p>Defective control.</p> <ul style="list-style-type: none"> • Replace controller unit. 	

TRACTION STATUS CODE	DESCRIPTION OF STATUS	CAUSE OF STATUS INDICATION
-49	Motor field current is too low during the run mode.	This status code will be displayed when the current draw in the motor field is too low during the run mode.
MEMORY RECALL NO	CORRECTIVE ACTIONS	<u>TROUBLE-SHOOTING DIAGRAM</u>
Circuits valid for Traction Controller	<p><u>SYMPTOM</u> Control will not operate.</p> <p><u>POSSIBLE CAUSE</u> Defective control.</p> <ul style="list-style-type: none"> • Replace controller unit. 	NO GRAPHIC FOR THIS STATUS CODE

TRACTION STATUS CODE	DESCRIPTION OF STATUS	CAUSE OF STATUS INDICATION
-51	Capacitor volts are low before the line contactor closes.	This status code will be displayed during "key on" when the capacitor volts is less than 85% of battery volts at initial key switch on.
MEMORY RECALL NO	CORRECTIVE ACTIONS	<u>TROUBLE-SHOOTING DIAGRAM</u>
Circuits valid for Traction Controller	<p><u>SYMPTOM</u> Line contactor does not close when capacitor does not precharge.</p> <p><u>POSSIBLE CAUSE</u> Defective control fuse.</p> <ul style="list-style-type: none"> • Check control fuse for open circuit. Replace fuse, if necessary. <p>Defective control.</p> <ul style="list-style-type: none"> • Replace controller unit. 	<p>The diagram illustrates the electrical circuit for the left control system. It starts with a 'LINE' input passing through a fuse 'FU1'. This line then branches into two paths: one through fuse 'FU4' to the 'STEER PUMP ARM' (terminals A1 and A2) and another to the 'STEER PUMP FIELD' (terminals S1 and S2). A capacitor 'SP' is connected to the field circuit. The circuit also includes a 'POWER CONNECTIONS LEFT CONTROL' block with terminals POS, A1, F1, NEG, A2, and F2. The 'ARMATURE' is connected to the field circuit. A battery symbol is shown on the left, with a note 'TO PUMP CONTROL POSITIVE' pointing to the positive terminal.</p>

TRACTION STATUS CODE	DESCRIPTION OF STATUS	CAUSE OF STATUS INDICATION
-57	Controller "motor current sensor" input too low during running.	This status code will be displayed when the voltage input from the current sensor is too low during running.
MEMORY RECALL NO	CORRECTIVE ACTIONS	<u>TROUBLE-SHOOTING DIAGRAM</u>
Circuits valid for Traction Controller	<p><u>SYMPTOM</u> Control will not operate.</p> <p><u>POSSIBLE CAUSE</u> Defective control.</p> <ul style="list-style-type: none"> • Replace controller unit. 	<p>NO GRAPHIC FOR THIS STATUS CODE</p>

TRACTION STATUS CODE	DESCRIPTION OF STATUS	CAUSE OF STATUS INDICATION
-63	There is an open circuit in the steer pump contactor coil.	This status code will be displayed when P18 does not see battery voltage while the contactor is open.
MEMORY RECALL YES	CORRECTIVE ACTIONS	<u>TROUBLE-SHOOTING DIAGRAM</u>
Circuits valid for Traction Controller	<p><u>SYMPTOM</u> Control will not operate.</p> <p><u>POSSIBLE CAUSE</u> Missing steer pump contactor coil wire.</p> <ul style="list-style-type: none"> • Verify steer pump contactor coil wiring. <p>Defective steer pump contactor coil.</p> <ul style="list-style-type: none"> • Replace steer pump contactor coil. <p>Defective control.</p> <ul style="list-style-type: none"> • Replace controller unit. 	<p>The diagram shows a KEY SWITCH connected to a power source. The circuit branches into four paths leading to terminals P1, P2, P18, and P17. The path to P18 includes a component labeled 'SP' (Steer Pump) and the path to P17 includes a component labeled 'L' (Load).</p>

TRACTION STATUS CODE	DESCRIPTION OF STATUS	CAUSE OF STATUS INDICATION
-64	There is an open circuit in the line contactor coil.	This status code will be displayed when P17 does not see battery voltage while the contactor is open.
MEMORY RECALL YES	CORRECTIVE ACTIONS	<u>TROUBLE-SHOOTING DIAGRAM</u>
Circuits valid for Traction Controller	<p><u>SYMPTOM</u> Control will not operate.</p> <p><u>POSSIBLE CAUSE</u> Missing line contactor coil wire.</p> <ul style="list-style-type: none"> • Verify line contactor coil wiring. <p>Defective line contactor coil.</p> <ul style="list-style-type: none"> • Replace line contactor coil. <p>Defective control.</p> <ul style="list-style-type: none"> • Replace controller unit. 	

TRACTION STATUS CODE	DESCRIPTION OF STATUS	CAUSE OF STATUS INDICATION
-65	There is a short in either the steer pump or the line contactor coil.	This status code will be displayed when either the steer pump or the line contactor coil is shorted.
MEMORY RECALL YES	CORRECTIVE ACTIONS	<u>TROUBLE-SHOOTING DIAGRAM</u>
Circuits valid for Traction Controller	<p><u>SYMPTOM</u> Control will not operate.</p> <p><u>POSSIBLE CAUSE</u> Shorted steer pump contactor coil.</p> <ul style="list-style-type: none"> • Verify steer pump contactor coil wiring. <p>Shorted line contactor coil.</p> <ul style="list-style-type: none"> • Verify line contactor coil wiring. <p>Defective control.</p> <ul style="list-style-type: none"> • Replace controller unit. 	

TRACTION STATUS CODE	DESCRIPTION OF STATUS	CAUSE OF STATUS INDICATION
-66	The field current exceeds the current limit of the field transistor.	This status code will be displayed when the field transistor exceeds its specific current limit. The line contactor will drop out and the key switch will have to be recycled to restart the control.
MEMORY RECALL YES	CORRECTIVE ACTIONS	TROUBLE-SHOOTING DIAGRAM
Circuits valid for Traction Controller	<p>SYMPTOM Control will not operate</p> <ul style="list-style-type: none"> Line contactor opens <p>POSSIBLE CAUSE</p> <ul style="list-style-type: none"> Shorted field F1 to F2 F1 or F2 terminals shorted to battery positive (B+) F1 or F2 terminals shorted to battery negative (B-) 	

TRACTION STATUS CODE	DESCRIPTION OF STATUS	CAUSE OF STATUS INDICATION
-68	The PMT enable signal from the slave control to the master control drops below 5V.	This status code will be displayed when the voltage at PL21 of the master control drops below 5V.
MEMORY RECALL NO	CORRECTIVE ACTIONS	TROUBLE-SHOOTING DIAGRAM
Circuits valid for Traction Controller	<p>SYMPTOM Control will not operate.</p> <p>POSSIBLE CAUSE Slave control has shut down.</p> <ul style="list-style-type: none"> Check the slave control for stored fault codes. Verify the connection between P21 of the master control and P10 of the slave control. 	

TRACTION STATUS CODE	DESCRIPTION OF STATUS	CAUSE OF STATUS INDICATION
-76	Capacitor (1C) voltage too high.	This status code will be displayed when the voltage on the capacitor goes above 96 volts during the regenerative braking cycle.
MEMORY RECALL YES	CORRECTIVE ACTIONS	<u>TROUBLE-SHOOTING DIAGRAM</u>
Circuits valid for Traction Controller	<p><u>SYMPTOM</u> Line contactor opens and closes, then opens and can only close by opening and closing the key switch.</p> <p><u>POSSIBLE CAUSE</u></p> <ul style="list-style-type: none"> • Unplugging the battery connector during regenerative braking. • Line contactor bouncing open during regen. • Main power fuse opening during regen. • Intermittent battery plug connection. 	

TRACTION STATUS CODE	DESCRIPTION OF STATUS	CAUSE OF STATUS INDICATION
-77	Motor current is detected during regenerative braking.	This status code will be displayed when motoring current is detected during the regenerative braking cycle.
MEMORY RECALL YES	CORRECTIVE ACTIONS	<u>TROUBLE-SHOOTING DIAGRAM</u>
Circuits valid for Traction Controller	<p><u>SYMPTOM</u> Line contactor opens and closes, then opens and can only close by opening and closing the key switch.</p> <p><u>POSSIBLE CAUSE</u> Defective control.</p> <ul style="list-style-type: none"> • Replace controller unit 	

TRACTION STATUS CODE	DESCRIPTION OF STATUS	CAUSE OF STATUS INDICATION
-82	No data is received from the opposite control when expected.	This status code will be displayed when no data has been received from the opposite control in over 3 seconds.
MEMORY RECALL NO	CORRECTIVE ACTIONS	<u>TROUBLE-SHOOTING DIAGRAM</u>
Circuits valid for Traction Controller	<p><u>SYMPTOM</u> Control does not operate.</p> <p><u>POSSIBLE CAUSE</u> Loss of the RS232 connection between the master and slave controls.</p> <ul style="list-style-type: none"> • PY11 in the slave control is not connected. • PY12 in the master control is not connected. • PY12 in the slave control is not connected. • PY11 in the master control is not connected. <p>Defective controller unit.</p> <ul style="list-style-type: none"> • Replace control. 	

TRACTION STATUS CODE	DESCRIPTION OF STATUS	CAUSE OF STATUS INDICATION
-83	A switch fault existed at the beginning of the potentiometer auto calibration routine.	This fault occurs when wither the seat switch is open, or one or both of the forward/reverse or start switches is closed when beginning the potentiometer auto calibration routine.
MEMORY RECALL NO	CORRECTIVE ACTIONS	<u>TROUBLE-SHOOTING DIAGRAM</u>
Circuits valid for Traction Controller	<p><u>SYMPTOM</u> "-83" status code appears on the dash display.</p> <p><u>POSSIBLE CAUSE</u> The seat switch is open.</p> <ul style="list-style-type: none"> • Close the seat switch and repeat the auto calibration routine. <p>The start switch is closed.</p> <ul style="list-style-type: none"> • Open the start switch and repeat the auto calibration routine. <p>The forward switch is closed.</p> <ul style="list-style-type: none"> • Open the forward switch and repeat the auto calibration routine. <p>The reverse switch is closed.</p> <ul style="list-style-type: none"> • Open the reverse switch and repeat the auto calibration routine. 	

TRACTION STATUS CODE	DESCRIPTION OF STATUS	CAUSE OF STATUS INDICATION
-84	A "time out" fault occurred in the potentiometer auto calibration routine.	This status code will be displayed when either control does not receive RS232 data from the opposite control during the potentiometer auto calibration routine.
MEMORY RECALL NO	CORRECTIVE ACTIONS	<u>TROUBLE-SHOOTING DIAGRAM</u>
Circuits valid for Traction Controller	<p><u>SYMPTOM</u> "-84" status code appears on the dash display. Operator is unable to proceed through the auto calibration routine.</p> <p><u>POSSIBLE CAUSE</u> Loss of the RS232 connection between the master and slave controls.</p> <ul style="list-style-type: none"> • PY11 in the slave control is not connected. • PY12 in the master control is not connected. • PY12 in the slave control is not connected. • PY11 in the master control is not connected. <p>Defective controller unit.</p> <ul style="list-style-type: none"> • Replace control. 	

TRACTION STATUS CODE	DESCRIPTION OF STATUS	CAUSE OF STATUS INDICATION
-85	Faulty data has been transmitted during the potentiometer auto calibration routine.	This status code will be displayed when either control receives faulty data during the potentiometer auto calibration routine.
MEMORY RECALL NO	CORRECTIVE ACTIONS	<u>TROUBLE-SHOOTING DIAGRAM</u>
Circuits valid for Traction Controller	<p><u>SYMPTOM</u> "-85" status code appears on the dash display.</p> <p><u>POSSIBLE CAUSE</u> Defective controller unit.</p> <ul style="list-style-type: none"> • Replace control. 	<p style="text-align: center;">NO GRAPHIC FOR THIS STATUS CODE</p>

TRACTION STATUS CODE	DESCRIPTION OF STATUS	CAUSE OF STATUS INDICATION						
-86	The control cannot complete the potentiometer auto calibration routine due to potentiometer settings which are out of range.	This status code will be displayed when any of the potentiometer values do not meet the criteria outlined below during the potentiometer auto calibration routine.						
MEMORY RECALL NO	CORRECTIVE ACTIONS	<u>TROUBLE-SHOOTING DIAGRAM</u>						
Circuits valid for Traction Controller	<p><u>SYMPTOM</u> "-86" status code appears on the dash display.</p> <p><u>POSSIBLE CAUSE</u> Accelerator, steer angle or brake pots require external adjustment.</p> <p>Accelerator, steer angle or brake pots are currently set out of the range identified below.</p> <p>Defective controller unit.</p> <ul style="list-style-type: none"> Replace control. 	<p>NO GRAPHIC FOR THIS STATUS CODE</p>						
	<table border="1"> <tr> <td>Accelerator Pot</td> <td> <ul style="list-style-type: none"> Wiper voltage is greater than 4.5 volts Span voltage is less than 2.6 volts </td> </tr> <tr> <td>Steer Angle Pot</td> <td> <ul style="list-style-type: none"> Wheel must be straight Wiper voltage cannot be between 1.90 and 2.40 volts </td> </tr> <tr> <td>Brake Pot</td> <td> <ul style="list-style-type: none"> Low brake pot wiper value of less than 0.75 volts </td> </tr> </table>		Accelerator Pot	<ul style="list-style-type: none"> Wiper voltage is greater than 4.5 volts Span voltage is less than 2.6 volts 	Steer Angle Pot	<ul style="list-style-type: none"> Wheel must be straight Wiper voltage cannot be between 1.90 and 2.40 volts 	Brake Pot	<ul style="list-style-type: none"> Low brake pot wiper value of less than 0.75 volts
	Accelerator Pot		<ul style="list-style-type: none"> Wiper voltage is greater than 4.5 volts Span voltage is less than 2.6 volts 					
	Steer Angle Pot		<ul style="list-style-type: none"> Wheel must be straight Wiper voltage cannot be between 1.90 and 2.40 volts 					
Brake Pot	<ul style="list-style-type: none"> Low brake pot wiper value of less than 0.75 volts 							

TRACTION STATUS CODE	DESCRIPTION OF STATUS	CAUSE OF STATUS INDICATION
-99	Controls are going through the start up sequence.	This status code will be displayed when the key switch is initially turned on.
MEMORY RECALL NO	CORRECTIVE ACTIONS	<u>TROUBLE-SHOOTING DIAGRAM</u>
Circuits valid for Traction Controller	<p><u>SYMPTOM</u> Control will not operate.</p> <p><u>POSSIBLE CAUSE</u> Controls are going through the start up sequence.</p> <ul style="list-style-type: none"> Wait until controls complete start up sequence. 	<p>NO GRAPHIC FOR THIS STATUS CODE</p>

TRACTION STATUS CODE	DESCRIPTION OF STATUS	CAUSE OF STATUS INDICATION
-2XX	Both controls will display status codes in the -2xx series, i.e. -201 to -299, indicating a status code mismatch.	This status code will be displayed in both the master and the slave controls, indicating a fault has occurred in the slave control only.
MEMORY RECALL NO	CORRECTIVE ACTIONS	<u>TROUBLE-SHOOTING DIAGRAM</u>
Circuits valid for Traction Controller	<p><u>SYMPTOM</u> Control will not operate.</p> <p><u>POSSIBLE CAUSE</u> Slave control has experienced a fault, while the master control attempts to operate normally.</p> <ul style="list-style-type: none"> Resolve the corresponding fault indicated by the last two digits of the status code which has occurred in the slave control. 	<p>Example:</p> <p>Both controls exhibit a -201 status code. The fault, as defined by status code -01 (missing seat switch or deadman switch signal), has occurred <u>only</u> with the slave control. However, neither control will operate, and both will continue to indicate the -201 status code, until the slave control fault has been cleared.</p>

TRACTION STATUS CODE	DESCRIPTION OF STATUS	CAUSE OF STATUS INDICATION
-3XX	Both controls will display status codes in the -3xx series, i.e. -301 to -399, indicating a status code mismatch.	This status code will be displayed in both the master and the slave controls, indicating a fault has occurred in the master control only.
MEMORY RECALL NO	CORRECTIVE ACTIONS	<u>TROUBLE-SHOOTING DIAGRAM</u>
Circuits valid for Traction Controller	<p><u>SYMPTOM</u> Control will not operate.</p> <p><u>POSSIBLE CAUSE</u> Master control has experienced a fault, while the slave control attempts to operate normally.</p> <ul style="list-style-type: none"> Resolve the corresponding fault indicated by the last two digits of the status code which has occurred in the master control. 	<p>Example:</p> <p>Both controls exhibit a -301 status code. The fault, as defined by status code -01 (missing seat switch or deadman switch signal), has occurred <u>only</u> with the master control. However, neither control will operate, and, both will indicate the -301 status code, until the master control fault has been cleared.</p>

Section 5.0 SX FAMILY GE HANDSET INSTRUCTIONS

Section 5.1 General Features

The GE Handset is a multi-functional tool to be used with the LX, ZX, and SX Series GE solid-state controls. The Handset consists of a Light Emitting Diode (LED) display and a keyboard for data entry. *Note: A different handset cord is required for use with SX controls than that used with LX and ZX controls.*

Section 5.2 Purpose / Setup Functions

The purpose of the Handset is to allow authorized personnel to perform the following functions of the SX family of Controls:

- Monitor existing system fault codes
- Monitor intermittent random fault codes
- Monitor battery state of charge on systems with BDI
- Monitor hourmeter reading
- Monitor or adjust the following control functions:
 - Creep speed
 - Armature Controlled Acceleration and 1A Time
 - Regenerative Braking Current Limit and Disable
 - Armature and Field Current Limit
 - Plugging Distance (Current)
 - Pedal Position Plug Range or Disable
 - 1A Drop Out Current or Disable
 - Speed Limit Points
 - Truck Management Fault Speed Limit
 - Internal Resistance Compensation for Battery State of Charge Indication
 - Battery Voltage (36/48 volts is auto ranging)
 - Selection of Card Operation Type.

Warning: Before connecting or disconnecting the Handset tool, turn off the key switch, unplug the battery and jack up the drive wheels of the vehicle.

At the transistor control traction card, unplug the "Y plug" if the dash display is in use, and plug in the Handset to the plug location "Y" on the control card. After installing the Handset tool, plug the battery in and turn the key switch on. The chart at the right details the start-up display sequence that will occur.

Note: The dash display must be disconnected when the Handset is plugged in, or the control power supply will be overloaded.

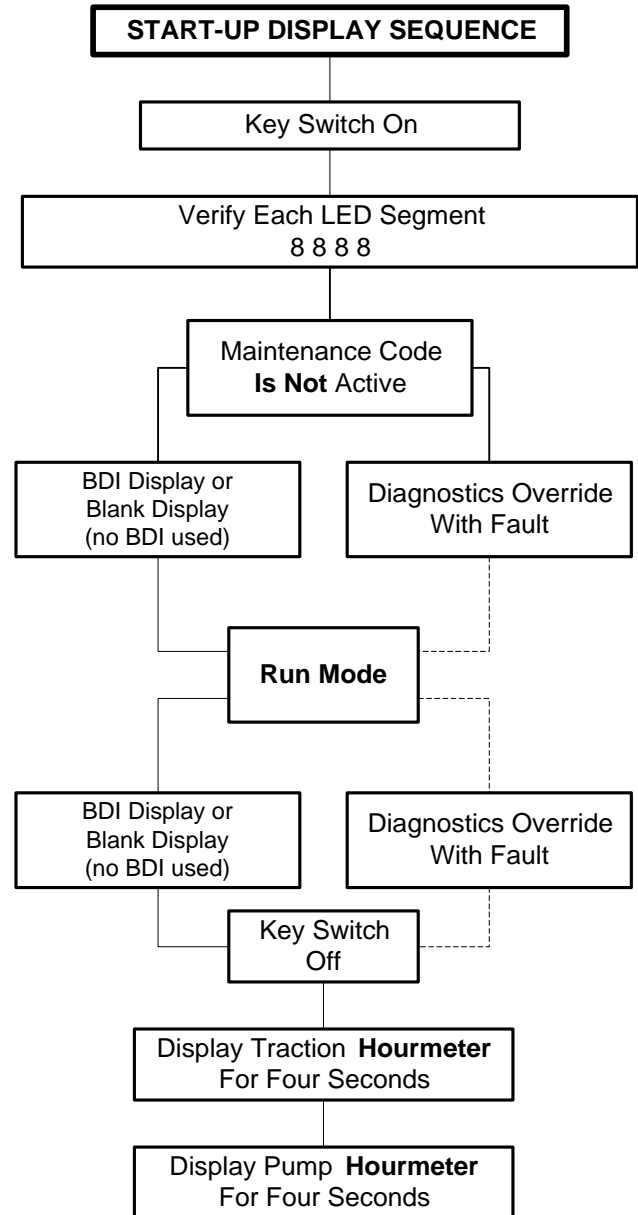

Warning: Before making any adjustments to the control, you must consult the operating and maintenance instructions supplied by the vehicle manufacturer. Failure to follow proper set up instructions could result in mis-operation or damage to the control system.

Section 5.3 Setup Function Procedures

With the Handset connected, hold down the CONT key and turn on the key switch. This will place you in the setup mode, ready to monitor or adjust control function settings.

NOTE: The term "Push" means to depress key for approximately one second.

Section 5.3.1 Setup Mode

SET-UP MODE		
ACTION	DISPLAY SHOWS	REMARKS
Hold Down CONT And Turn On Key	8 8 8 8	Segment Check Displayed
Push Function Number	U 0 0 5	Selected Function No. Is Displayed
After One Second Time Delay	0 8 5	Stored Value For The Function Is Displayed
Push CONT	0 8 5	Display Value Will Blink
Change Value with Adjustment Knob	1 2 5	Value Changes While Blinking
Push STORE	1 2 5	New Value Stored And Blinking Stops
Push ESC	8 8 8 8	Segment Check Displayed

At this point, another function can be monitored/changed by pushing another function number, or the vehicle can be placed in the run mode by holding the ESC key down for one second or longer. The display will return to either the diagnostics mode, the BDI display, or a blank display (if BDI is not used and there are no fault codes). The vehicle can now be operated with the Handset connected or the Handset can be disconnected before operation.

NOTE: You can return to the segment check mode at any time, by holding down the ESC key until 8888 appears in the display.

Section 5.3.2 Status Code Scrolling

The SX family of controllers furnishes a function register that contains the last 16 "stored status codes" that shut down vehicle operation (a PMT type fault that is reset by cycling the key switch) and the battery state of charge reading at the time the fault occurred. The first of the 16 status codes will be overwritten each time a new status code occurs. This stored status code register can be cleared from memory by using the Handset.

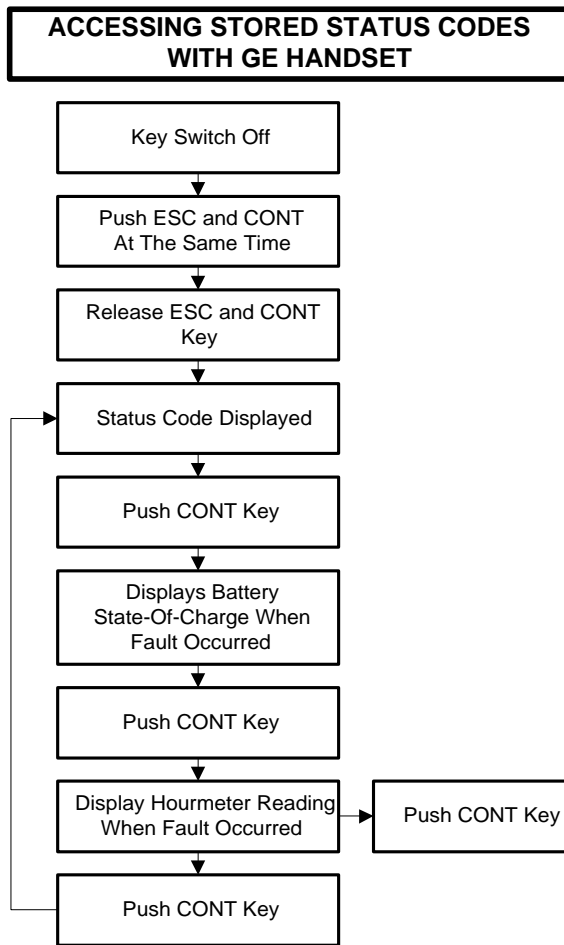

Section 5.3.3 SX Family Handset, Plug Connections and Outline Drawing

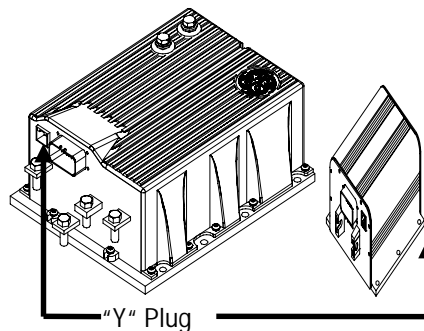

Handset Cable Part Number - 325B1002G1 (12 pin plug)
Handset Part Number - IC3645LXHS1EC2 (12 pin plug)
(includes handset, cable and case)

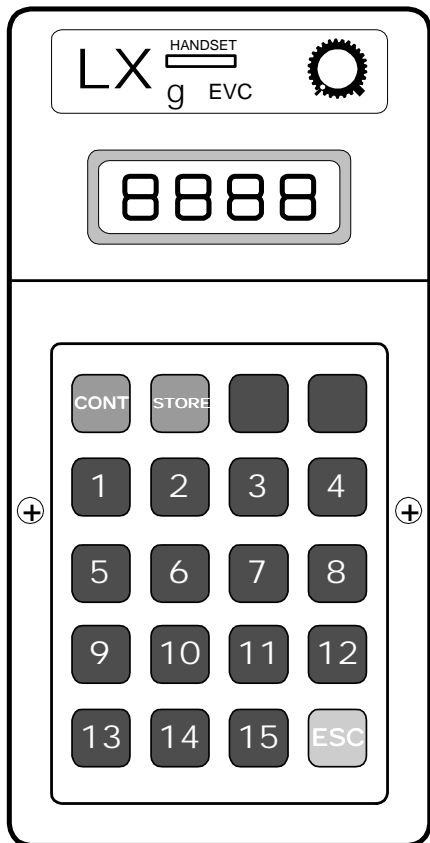

Section 5.4 Setup Functions for Traction Controller

FUNCTION 1 MODE SELECT (Push 1)

Available mode selections are defined in the following table:

Mode	Handset Setting
1	0 to 63
2	64 to 127
3	128 to 255

FUNCTION 2 CREEP SPEED (Push 2)

This function allows for the adjustment of the creep speed of the vehicle. Creep speed can be adjusted when an accelerator input voltage between 3.9 and 3.3 volts or an accelerator ohm input between 6.0 K and 4.0K ohms is provided. For ease of handset adjustment, every eight set points increases the percent on time by 0.2%. *Note, the controller always rounds decimal answers down to the nearest integer during these division calculations.*

Range	2% to 15% on time
Set	0 to 255
Resolution	0.2% per eight set units
Example:	Setting of 20 = 0.4% on time

Important Note: The function is used to optimize motor and control performance and this setting will be determined by GE and OEM engineers at the time of vehicle development. This setting must not be changed by field personnel without the permission of the OEM.

FUNCTION 3 NOT APPLICABLE

This function is not applicable to this type of control and should not be adjusted.

FUNCTION 4 ARMATURE CURRENT LIMIT (Push 4)

This function allows for the adjustment of the armature current limit of the control. The armature current limit at 50% on time is defined by the following equation, where the maximum function value is 255 and the minimum function value is 0:

$$I_A = 418 - [(255 - \text{function value}) / 8] \times 6.5$$

Note, the controller always rounds decimal answers down to the nearest integer during these division calculations.

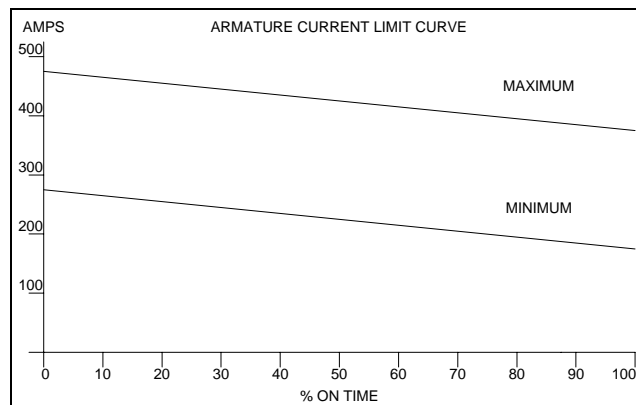

FUNCTION 5 PLUGGING CURRENT LIMIT (Push 5)

This function allows for the adjustment of the plugging distance of the vehicle. The larger the current setting, the shorter the stopping distance. The correlation between the function setting and the actual plug current limit is expressed by the following equation:

$$I_p = [(\text{Function value} / 4) + 8] \times 6.5$$

Range	117 to 400 amps
Set	41 to 216
Example:	Setting of 50 = 130 amps

Note, the controller always rounds decimal answers down to the nearest integer during these division calculations.

FUNCTION 6 NOT APPLICABLE

This function is not applicable to this control type and should not be adjusted.

FUNCTION 7 NOT APPLICABLE

This function is not applicable to this control type and should not be adjusted.

FUNCTION 8 NOT APPLICABLE

This function is not applicable to this control type and should not be adjusted.

FUNCTION 9 NOT APPLICABLE

This function is not applicable to this control type and should not be adjusted.

FUNCTION 10 ARMATURE CURRENT RAMP DOWN RATE

This function allows for the adjustment of the length of time required to ramp armature current to zero when transitioning from motoring to some other state of operation.

FUNCTION 11 TURN ANGLE POT SPEED LIMIT (Push 11)

This function allows for the adjustment of the vehicle speed during a 90° turn, per the curves below:

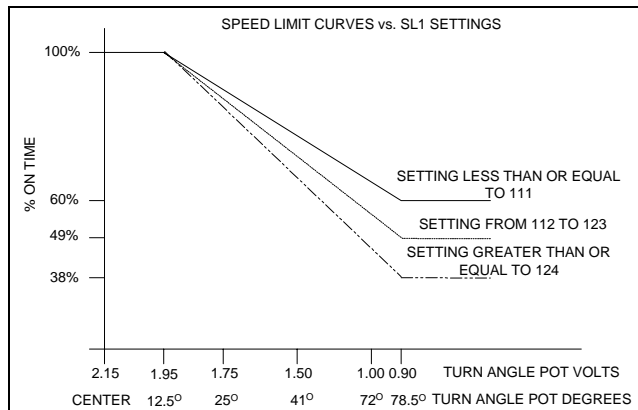

FUNCTION 12 "TOP SPEED" SPEED LIMIT (Push 12)

This function allows for the adjustment of the top speed motor volts as a percentage of battery volts

Range	100% to 0% of battery volts
Setting	45 to 180
Resolution	0.7% per set unit

Example Setting of 75 = 73.5% of battery volts

FUNCTION 13 NOT APPLICABLE

This function is not applicable to this control type and should not be adjusted.

FUNCTION 14 INTERNAL RESISTANCE COMPENSATION (Push 14)

This function is used when the Battery Discharge Indicator is present. Adjustment of this function will improve the accuracy of the BDI. In order to determine this setting, the voltage drop of the battery under load must first be calculated by the following method:

1. Record open circuit voltage (V_o) by measuring the voltage at the control positive and negative power terminals.
2. Load the battery to 100 amps in 1A and record the voltage (V_L) at the control positive and negative power terminals.
3. Calculate voltage drop (V_{Drop}) as follows:
$$V_{Drop} = V_o - V_L$$
4. Use the table below to determine the appropriate setting using the calculated V_{Drop} as a reference.

INTERNAL RESISTANCE COMPENSATION TABLE

Setting	V_{Drop}	Setting	V_{Drop}
2	11.44	17	1.34
3	7.60	18	1.27
4	5.72	19	1.20
5	4.57	20	1.14
6	3.81	21	1.09
7	3.27	22	1.04
8	2.86	23	0.99
9	2.54	24	0.95
10	2.28	25	0.91
11	2.08	26	0.88
12	1.90	27	0.85
13	1.76	28	0.82
14	1.63	29	0.79
15	1.52	30	0.76
16	1.43	31	0.74

FUNCTION 15 NOT APPLICABLE

This function is not applicable to this control type and should not be adjusted.

The following functions have function numbers larger than the numbers on the Handset keyboard. To access these functions, push the CONT key and the number shown in the instructions at the same time. THE SEAT SWITCH MUST BE OPEN.

FUNCTION 16 BDI FLASH LEVEL
(Push CONT 1)

This function allows for the adjustment of the percent of battery charge point at which the dash display begins to flash. At 11% below the setting point of this function, the lift function will be cut off. If the setting is 10 or lower, the lift will not be cut off.

Range	90% to 0%
Setting	90 to 0
Resolution	1% per set unit
Example	Setting of 20 = 20%

FUNCTION 17 CARD TYPE SELECTION
(Push CONT 2)

This function allows for the selection of the card type used for your vehicle's application, i.e. a master control (left) or a slave (right) control. The table below shows the setting to select card application type, depending on which control card is used. *Note that the right (slave) control for a dual motor proportioning system will be set differently than the left (master) control.*

Functions	Setting
Master (left)	0 to 63
Slave (right)	64 to 255

Warning: These settings must be changed by authorized personnel only, following instructions supplied by the vehicle manufacturer.

FUNCTION 18 SEAT TIMER
(Push CONT 3)

This function allows for the adjustment of the time allowable for the seat switch to be open before the control opens the line and steer pump contactors.

Range	0 to 64 seconds
Setting	0 to 128
Resolution	0.5 seconds per set unit
Example	Setting of 20 = 10 seconds

FUNCTION 19 NOT APPLICABLE

This function is not applicable to this control type and should not be adjusted.

FUNCTION 20 NOT APPLICABLE

This function is not applicable to this control type and should not be adjusted.

FUNCTION 21 AUTO REGEN CURRENT LIMIT
(Push CONT 6)

This function allows for the adjustment of the regen braking current limit when the brake pot is fully depressed. The correlation between the function setting and the regen braking current limit is expressed by the following equation:

$$I_R = [(function\ setting/4) \times 6.5]$$

Range	52 to 409 amps
Set	32 to 255
Example:	Setting of 100 = 162 amps

Note, the controller always rounds decimal answers down to the nearest integer during these division calculations.

FUNCTION 22 AUTO CALIBRATION OF POTS
(Push CONT 7)

This function allows for autocalibration of the accelerator, brake and steer angle potentiometers. For detailed procedure, refer to Section 8.

FUNCTION 23 NOT APPLICABLE

This function is not applicable to this control type and should not be adjusted.

FUNCTION 24 NOT APPLICABLE

This function is not applicable to this control type and should not be adjusted.

FUNCTION 25 MONITOR
(Push CONT 10)

This function allows the monitoring of certain control functions by looking directly at the RAM of the microprocessor. Because absolute memory locations need to be known, this function should not be used without detailed instructions from the GE application engineer.

To ensure optimum operation of the control, this function must be left with zero stored in this register.

FUNCTION 26 NOT APPLICABLE

This function is not applicable to this control type and should not be adjusted.

FUNCTION 28 STORED STATUS CODE COUNT POINTER
(Push CONT 13)

This register contains the location of the last stored status code recorded of the 16 stored status codes. These stored status codes have caused a PMT controller shutdown and/or disruption of normal vehicle operation.

To determine which stored status code was the last one recorded, read the number stored in Function 28. Using the **Memory Map** for your logic card, match the "stored status code pointer number" [the number shown in *(bold italics)* in the HS (Handset) number column] on the memory map, with the number obtained from Function 28. This will be the last stored status code recorded.

Note: When scrolling through the stored status code register, the register always starts at status code 1 and scrolls to status code 16. Instructions for scrolling the register are in section 5.3.2 of this instruction booklet.

USER SELECTABLE MODES

The following functions (Functions 48 through 62) are mode settings that are activated by Function 1. Each function must be set using the logic table shown below.

<u>Mode</u>	<u>Handset Setting</u>
1	0 to 63
2	64 to 127
3	128 to 255

Note: The following functions have function numbers larger than the numbers on the Handset keyboard. To access these functions, push the CONT key and the number shown in the following instructions at the same time. The seat switch must be closed.

FUNCTION 48 MODE 1 - ARMATURE CONTROLLED ACCELERATION
(Push CONT 1)

This function allows for the adjustment of the rate of time it takes for the control to accelerate to 100% applied battery voltage to the motor on hard acceleration. The 1A contactor will automatically close 0.2 seconds after the controlled acceleration stops and the accelerator input is less than 0.5 volts or less than 200 ohms.

Range	0.1 to 22.0 seconds
Set	0 to 255
Resolution	0.084 seconds per set unit
Example	Setting of 20 = 1.78 seconds C/A and 1.98 seconds 1A time

This C/A TIME takes effect when the Mode 1 settings are called for by Function 1.

FUNCTION 49 MODE 1 FIELD WEAKENING START
(Push CONT 2)

This function allows for setting the armature current at which minimum field current will be achieved.

Range	0 to 414 amps
Setting	0 to 255
Resolution	1.625 per set unit
Example	Setting of 20 = 32.5 amps

This FIELD WEAKENING START takes effect when the Mode 1 settings are called for by Function 1.

FUNCTION 50 MODE 1 MINIMUM FIELD CURRENT
(Push CONT 3)

This function allows the adjustment of the field weakening level in order to set the top speed of the motor.

Min	Max	Set	Resolution Per Unit Value	Example If set at 71
0	40	51 to 255	0.185 amps	3.7 amps

This MINIMUM FIELD CURRENT takes effect when the Mode 1 settings are called for by Function 1.

FUNCTION 51 MODE 1 RATIO
(Push CONT 4)

This function sets the ratio between armature and field current when transitioning from minimum field to maximum field current. The setting represents the quantity of field current changed for each 1 amp of armature current changed.

Max Setting	Max Change	Set	Resolution Per Unit Value	Example If Set at 5
255	.45	0 to 255	0.00175	0.0071 amps

This RATIO takes effect when the Mode 1 settings are called for by Function 1.

FUNCTION 52 MODE 1 REGEN ARMATURE CURRENT LIMIT
(Push CONT 5)

This function allows for the adjustment of the regen braking current limit of the control. The correlation between the function setting and the regen braking current is expressed by the following equation:

$$I_R = \text{[(function setting/4) x 6.5]}$$

Range 52 to 364 amps
Set 32 to 224
Example: Setting of 50 = 78 amps

**FUNCTION 53 MODE 2 CONTROLLED ACCELERATION
(Push CONT 6)**

Same as Function 48.

This CONTROLLED ACCELERATION takes effect when the Mode 2 settings are called for by Function 1.

**FUNCTION 54 MODE 2 FIELD WEAKENING START
(Push CONT 7)**

Same as Function 49.

This FIELD WEAKENING START takes effect when the Mode 2 settings are called for by Function 1.

**FUNCTION 55 MODE 2 MINIMUM FIELD CURRENT
(Push CONT 8)**

Same as Function 50.

This MINIMUM FIELD CURRENT takes effect when the Mode 2 settings are called for by Function 1.

**FUNCTION 56 MODE 2 RATIO
(Push CONT 9)**

Same as Function 51.

This RATIO takes effect when the Mode 2 settings are called for by the Function 1.

**FUNCTION 57 MODE 2 REGEN ARMATURE CURRENT
LIMIT
(Push CONT 10)**

Same as Function 52.

This REGEN ARMATURE CURRENT LIMIT takes effect when the Mode 2 settings are called for by Function 1.

**FUNCTION 58 MODE 3 CONTROL ACCELERATION
(Push CONT 11)**

Same as Function 48.

This CONTROL ACCELERATION takes effect when the Mode 3 settings are called for by Function 1.

**FUNCTION 59 MODE 3 FIELD WEAKENING START
(Push CONT 12)**

Same as Function 49.

This FIELD WEAKENING START takes effect when the Mode 3 settings are called for by Function 1.

**FUNCTION 60 MODE 3 MINIMUM FIELD
(Push CONT 13)**

Same as Function 50

This MINIMUM FIELD takes effect when the Mode 3 settings are called for by Function 1.

**FUNCTION 61 MODE 3 RATIO
(Push CONT 14)**

Same as Function 51.

This RATIO takes effect when the Mode 3 settings are called for by Function 1.

**FUNCTION 62 MODE 3 REGEN CURRENT LIMIT
(Push CONT 15)**

Same as Function 52.

This REGEN CURRENT LIMIT takes effect when the Mode 3 settings are called for by Function 1.

Section 5.5 Summary of Current Limit Adjustments

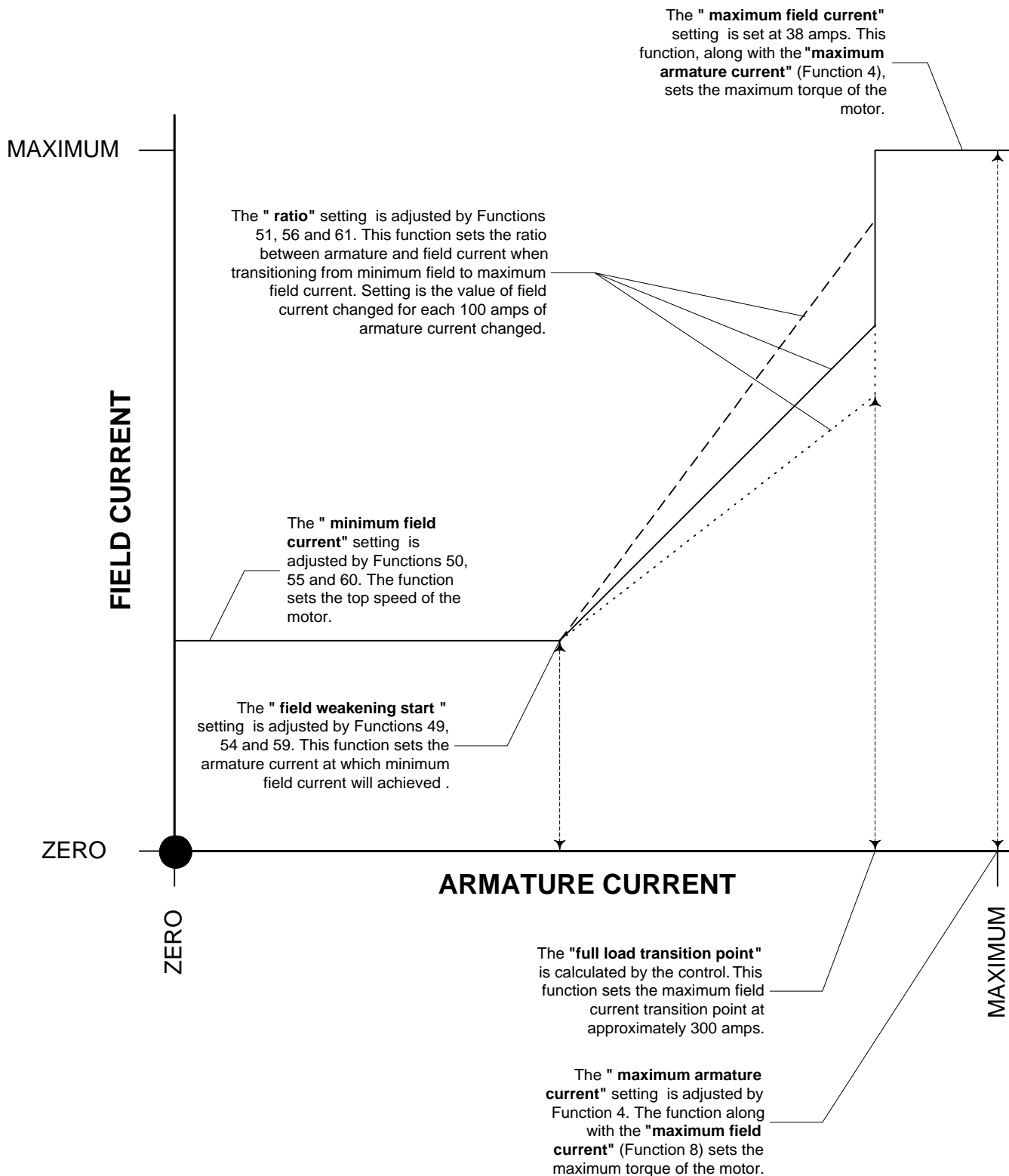

Section 6.0 DASH DISPLAYS

Section 6.1 Application

The SX family Standard and Interactive Dash Displays allow the operator and maintenance personnel easy access to truck operation information and real-time system diagnostics of the controller, motor and various accessories. Hourmeter readings, battery discharge information, maintenance information and system status codes are clearly displayed during startup and running modes. Shielded cable connections are made to the Dash Display by means of five (5) 22-gage wires to the "Y" Plug of the traction and hydraulic pump controls.

Section 6.2 Standard Dash Displays

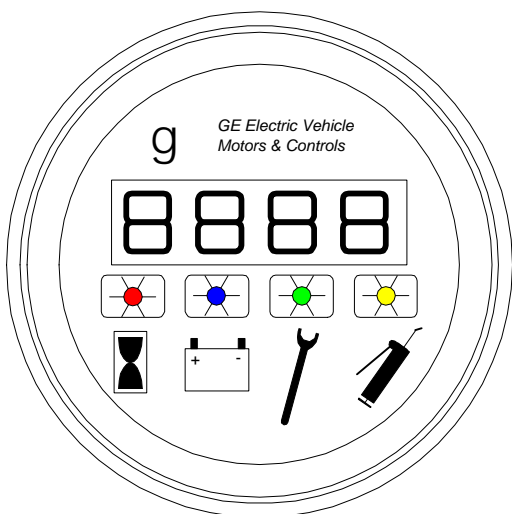

The GE Standard Dash Display is a four segment Light Emitting Diode (LED) instrument that displays the GE LX, ZX, and SX Status Codes, Hourmeter Readings, Battery Discharge Indication, and Maintenance Required Code. The four LED's above the symbols indicate the active readout mode.

Section 6.2.1 Connections

Connections are made to the Dash Display with five (5) 22-gage wires to Plug "Y" of each control. Shielded cable is required to eliminate signal interference.

Section 6.2.2 Part Number

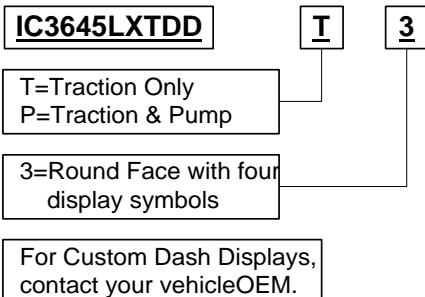

Section 6.2.3 Connector Reference Numbers

- AMP#102241-3 Dash Display mating plug
- AMP#1-87195-8 Dash Display mating pin
- 44A723596-G09 Dash Display plug kit
- AMP#175965-2 "Y" Plug
- AMP#175180-1 "Y" Plug receptacle

Section 6.3 Start-Up Display Sequence

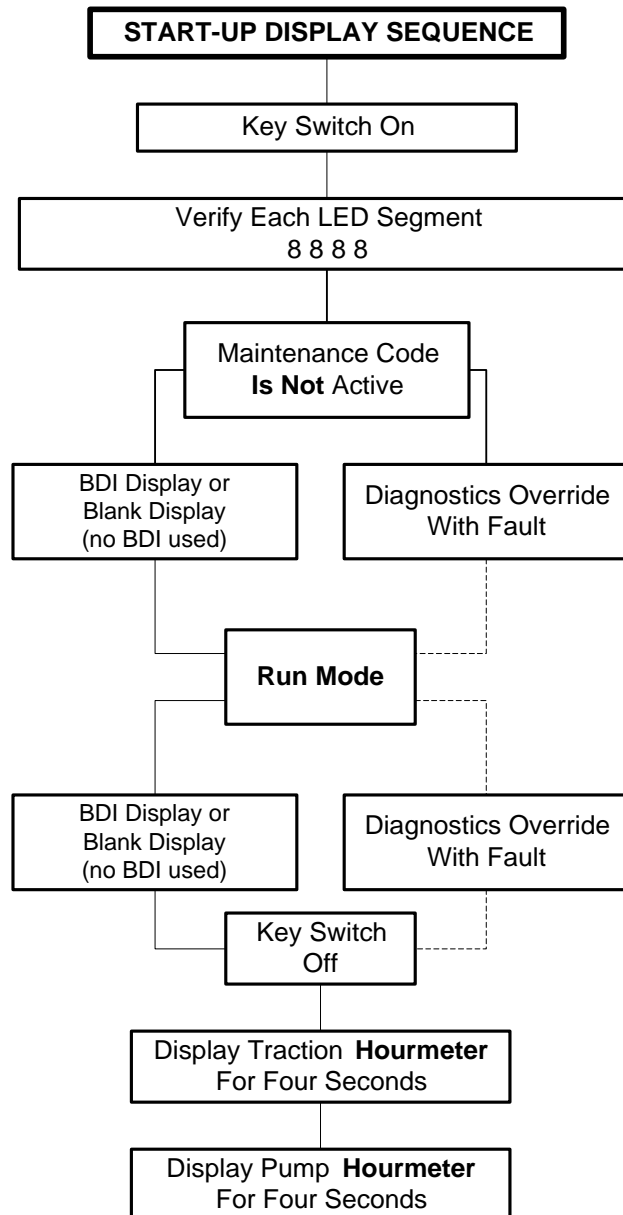

Section 6.4 Outline Drawings

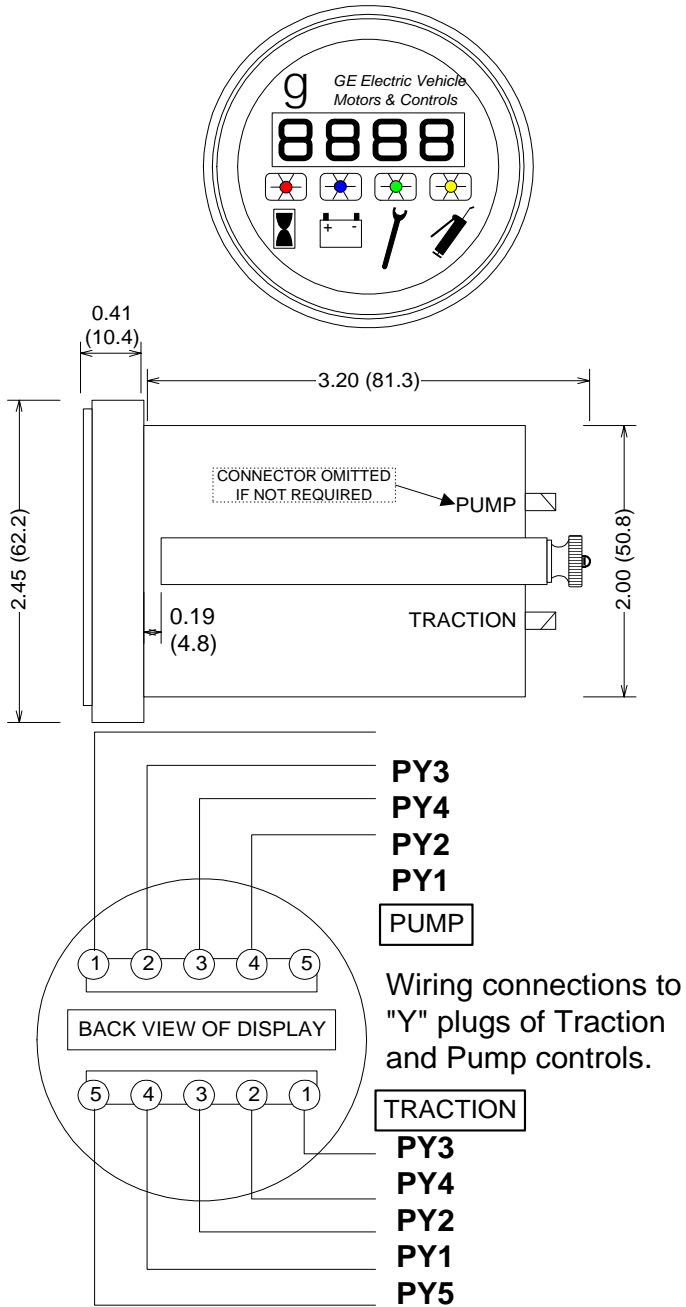

Section 7.0 TURN ANGLE POTENTIOMETER INSTALLATION

Section 7.1 General

The potentiometer used for the turn angle must be a 270 degree rotation device that is attached to the steer wheel in a manner to cause a 1:1 rotation ratio between the two devices. Any ohm value potentiometer can be used, but it is suggested that it be at least 2KW or above, to keep the wattage of the potentiometer to a minimum. The turn angle potentiometer provides a voltage divider circuit that allows the left and right motor controller to determine the turn angle of the rear steer wheel of the vehicle. The potentiometer is connected to the two controls as show in Figure 1. After the potentiometer is installed on the vehicle, it will need to be adjusted to insure proper operation of the vehicle.

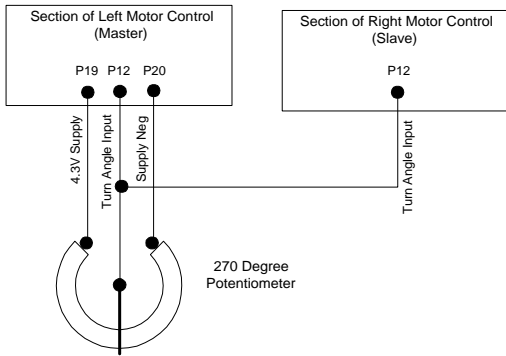

Figure 1

OPERATION:

To insure proper operation, the input voltage at P12 on both the left and right controls must coincide with the turn angle of the steer wheel. When the steer wheel is straight ahead (Zero Degree Turn Angle), the input voltage at each control should be 2.15 volts. As the vehicle turns left, this input voltage will decrease, as the vehicle turns right, the input voltage will increase. The graph in Figure 2 outlines the input voltages, the actions of the controls and the corresponding turn angles of the steer wheel. A complete listing of input voltages, steer angles and control actions can be found in **Section 7.2 - 270 Degree Potentiometer Input**. As an example of control operation as compared to the input voltage, the following series of events takes place in a left turn from the zero to 90 degree steer wheel position. In the first 16° of

travel (2.15 to 1.90 volts), there is no change to inside wheel speed. Between 16° (1.90V) and 78° (0.91V), the inside motor will reduce its speed linearly from 100% on-time to the value set by Function 11. The inside wheel will reduce its speed proportionally to the outside wheel speed, between 16° (1.90V) to 66° (1.10V). At an angle greater than 71° , the inside wheel reverses and operates at the speed indicated by the setting of Function 11.

SETUP:

Before any adjustments are done. Jack up the drive wheels.

Install the potentiometer on the vehicle steer wheel in such a way to allow adjustment of the shaft with the potentiometer and connected to both the left and right controls. Setup of the turn angle pot can be done in several ways, detailed below.

Volt Meter Method

Attach a volt meter, positive lead to P12 and negative lead to P20 of the control. Insure that the vehicle steering wheel is turned so that the wheels are pointed straight ahead (and the steer angle pot is at the zero degree angle). Connect the battery and adjust the potentiometer until the voltage between P12 and P20 is 2.15 volts. Complete the auto calibration routine for the steer angle potentiometer as outlined in Section 8 of this manual.

Section 7.2 270 Degree Potentiometer Input

270 DEGREE POTENTIOMETER FOR STEER ANGLE INPUT

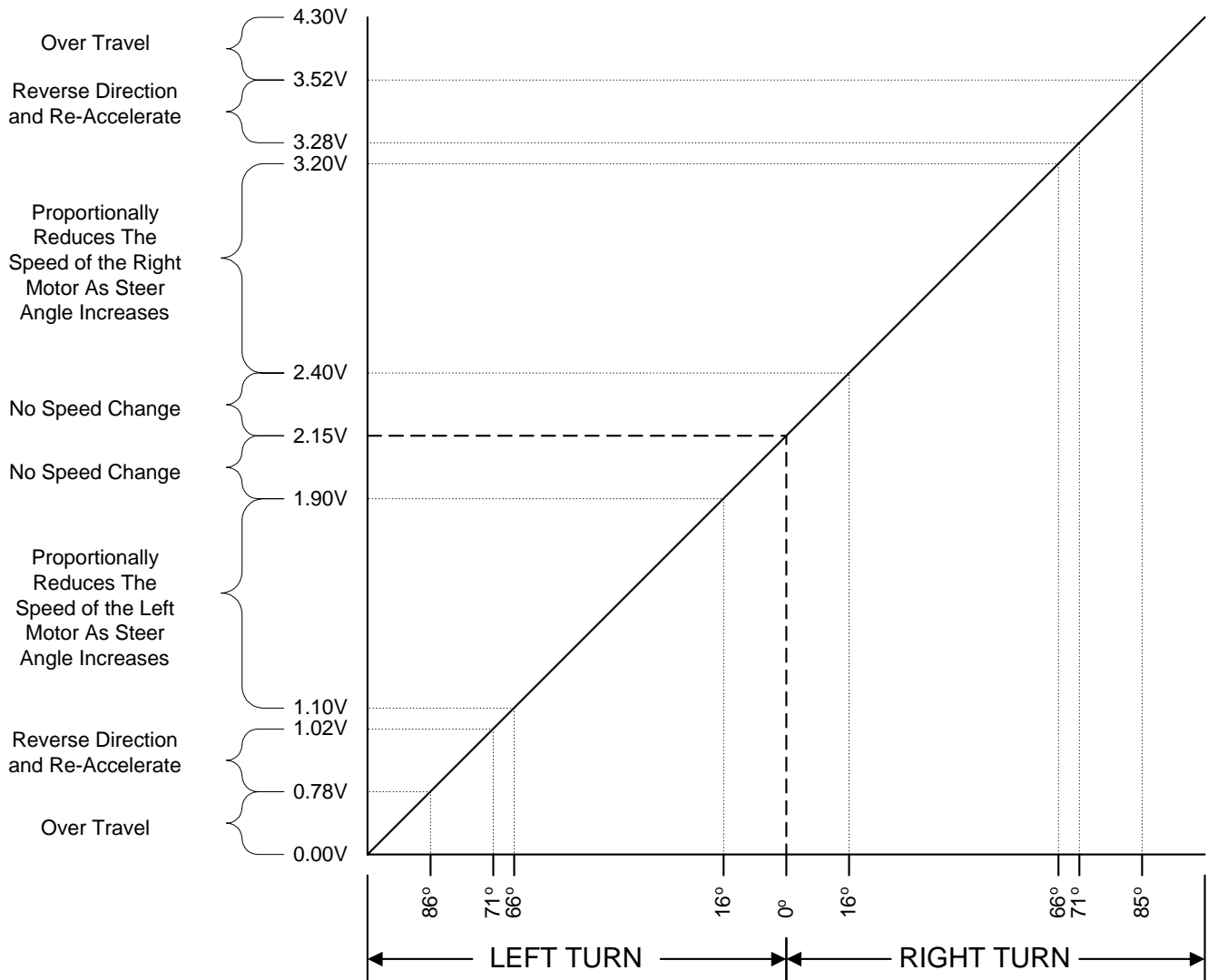

Figure 2

Section 7.3 Turn Angle Input Volts vs. Steer Wheel Degrees vs. Handset Readings

270 Degree Potentiometer						
Left			Right			Actions
Volts	Deg	HS	Volts	Deg	HS	
2.15	Ctr	110	2.15	Ctr	110	No Change
2.13	1	109	2.17	1	110	No Change
2.12	2	108	2.18	2	111	No Change
2.10	3	107	2.20	3	112	No Change
2.09	4	106	2.21	4	113	No Change
2.07	5	106	2.23	5	114	No Change
2.05	6	105	2.25	6	115	No Change
2.04	7	104	2.26	7	115	No Change
2.02	8	103	2.28	8	116	No Change
2.01	9	102	2.29	9	117	No Change
1.99	10	102	2.31	10	118	No Change
1.97	11	101	2.33	11	119	No Change
1.96	12	100	2.34	12	119	No Change
1.94	13	99	2.36	13	120	No Change
1.93	14	98	2.37	14	121	No Change
1.91	15	97	2.39	15	122	No Change
1.90	16	97	2.40	16	123	Proportional Reduce
1.88	17	96	2.42	17	123	Proportional Reduce
1.86	18	95	2.44	18	124	Proportional Reduce
1.85	19	94	2.45	19	125	Proportional Reduce
1.83	20	93	2.47	20	126	Proportional Reduce
1.82	21	93	2.48	21	127	Proportional Reduce
1.80	22	92	2.50	22	128	Proportional Reduce
1.78	23	91	2.52	23	128	Proportional Reduce
1.77	24	90	2.53	24	129	Proportional Reduce
1.75	25	89	2.55	25	130	Proportional Reduce
1.74	26	89	2.56	26	131	Proportional Reduce
1.72	27	88	2.58	27	132	Proportional Reduce
1.70	28	87	2.60	28	132	Proportional Reduce
1.69	29	86	2.61	29	133	Proportional Reduce
1.67	30	85	2.63	30	134	Proportional Reduce
1.66	31	84	2.64	31	135	Proportional Reduce
1.64	32	84	2.66	32	136	Proportional Reduce
1.62	33	83	2.68	33	136	Proportional Reduce
1.61	34	82	2.69	34	137	Proportional Reduce
1.59	35	81	2.71	35	138	Proportional Reduce
1.58	36	80	2.72	36	139	Proportional Reduce
1.56	37	80	2.74	37	140	Proportional Reduce
1.54	38	79	2.76	38	141	Proportional Reduce
1.53	39	78	2.77	39	141	Proportional Reduce
1.51	40	77	2.79	40	142	Proportional Reduce
1.50	41	76	2.80	41	143	Proportional Reduce
1.48	42	76	2.82	42	144	Proportional Reduce
1.47	43	75	2.83	43	145	Proportional Reduce
1.45	44	74	2.85	44	145	Proportional Reduce
1.43	45	73	2.87	45	146	Proportional Reduce

270 Degree Potentiometer						
Left			Right			Actions
Volts	Deg	HS	Volts	Deg	HS	
1.42	46	72	2.88	46	147	Proportional Reduce
1.40	47	71	2.90	47	148	Proportional Reduce
1.39	48	71	2.91	48	149	Proportional Reduce
1.37	49	70	2.93	49	149	Proportional Reduce
1.35	50	69	2.95	50	150	Proportional Reduce
1.34	51	68	2.96	51	151	Proportional Reduce
1.32	52	67	2.98	52	152	Proportional Reduce
1.31	53	67	2.99	53	153	Proportional Reduce
1.29	54	66	3.01	54	154	Proportional Reduce
1.27	55	65	3.03	55	154	Proportional Reduce
1.26	56	64	3.04	56	155	Proportional Reduce
1.24	57	63	3.06	57	156	Proportional Reduce
1.23	58	63	3.07	58	157	Proportional Reduce
1.21	59	62	3.09	59	158	Proportional Reduce
1.19	60	61	3.11	60	158	Proportional Reduce
1.18	61	60	3.12	61	159	Proportional Reduce
1.16	62	59	3.14	62	160	Proportional Reduce
1.15	63	58	3.15	63	161	Proportional Reduce
1.13	64	58	3.17	64	162	Proportional Reduce
1.11	65	57	3.19	65	162	Proportional Reduce
1.10	66	56	3.20	66	163	Creep Speed
1.08	67	55	3.22	67	164	Zero Speed
1.07	68	54	3.23	68	165	Zero Speed
1.05	69	54	3.25	69	166	Zero Speed
1.04	70	53	3.26	70	167	Zero Speed
1.02	71	52	3.28	71	167	Reverse
1.00	72	51	3.30	72	168	Reverse
0.99	73	50	3.31	73	169	Reverse
0.97	74	50	3.33	74	170	Reverse
0.96	75	49	3.34	75	171	Reverse
0.94	76	48	3.36	76	171	Reverse
0.92	77	47	3.38	77	172	Reverse
0.91	78	46	3.39	78	173	Reverse
0.89	79	45	3.41	79	174	Reverse
0.88	80	45	3.42	80	175	Reverse
0.86	81	44	3.44	81	175	Reverse
0.84	82	43	3.46	82	176	Reverse
0.83	83	42	3.47	83	177	Reverse
0.81	84	41	3.49	84	178	Reverse
0.80	85	41	3.50	85	179	Reverse
0.78	86	40	3.52	86	180	Reverse
0.76	87	39	3.54	87	180	Over Travel
0.75	88	38	3.55	88	181	Over Travel
0.73	89	37	3.57	89	182	Over Travel
0.72	90	37	3.58	90	183	Over Travel

**SECTION 8.0 AUTOCALIBRATION OF ACCELERATOR,
BRAKE AND STEER ANGLE POTENTIOMETERS**

Section 8.0 General

If Function 22 is set to a value of 250 or greater, the control will auto calibrate the accelerator, brake and steer angle potentiometers in succession. Individual auto calibration routines are detailed below.

Section 8.1 Calibration of the Accelerator Potentiometer

When calibrating the accelerator pot, program Function 22 to a value between 15 and 20, and then exit programming mode. Cycle the key switch on and off to store the function setting.

When returning the key switch to the "ON" position, make sure that the forward, reverse and start switches are open, and that the seat switch is closed. If one of these conditions is not met, a "-83" status code will appear on the dash display. Once all of the above conditions have been met, four "A" 's will appear on the dash display:

AAAA

When the four "A" 's are displayed, close the forward directional switch, with the accelerator pedal fully released. The dash display should show three "A" 's:

AAA

Return the forward switch to the open position, and the dash display should show two "A" 's:

AA

Fully depress the accelerator pedal and close the forward switch. Only one "A" should be displayed:

A

Reopen the forward switch. The truck will either return to a normal operating state or a "-86" status code will appear on the dash display. If the "-86" code appears, either the full accelerator pedal voltage was greater than 4.5 volts, or the voltage span from no pedal depression to full pedal depression was less than 2.6 volts. Either condition requires external adjustment to the accelerator pot prior to repeating the process above.

Section 8.2 Calibration of the Steer Angle Potentiometer

When calibrating the steer angle pot, program Function 22 to a value between 30 and 35, and then exit programming

mode. Cycle the key switch on and off to store the function setting.

When returning the key switch to the "ON" position, make sure that the forward, reverse and start switches are open, and that the seat switch is closed. If one of these conditions is not met, a "-83" status code will appear on the dash display. Once all of the above conditions have been met, four "U" 's will appear on the dash display:

UUUU

When the four "U" 's are displayed, close the forward directional switch, with the steering wheel positioned to keep the wheels straight ahead. The dash display should show three "U" 's:

UUU

Return the forward switch to the open position, and the dash display should show two "U" 's:

UU

Close the forward switch again. Only one "U" should be displayed:

U

Reopen the forward switch. The truck will either return to a normal operating state or a "-86" status code will appear on the dash display. If the "-86" code appears, either the center position for the steer angle pot is less than 1.90 volts or greater than 2.40 volts. Either condition requires external adjustment to the steer angle pot prior to repeating the process above.

Section 8.3 Calibration of the Brake Potentiometer

When calibrating the brake pot, program Function 22 to a value between 40 and 45, and then exit programming mode. Cycle the key switch on and off to store the function setting.

When returning the key switch to the "ON" position, make sure that the forward, reverse and start switches are open, and that the seat switch is closed. If one of these conditions is not met, a "-83" status code will appear on the dash display. Once all of the above conditions have been met, four "-" 's will appear on the dash display:

When the four "-" 's are displayed, close the forward directional switch, with the brake pedal fully released. The dash display should show three "-" 's:

Return the forward switch to the open position, and the dash display should show two "- " 's:

--

Close the forward switch again while fully depressing the brake pedal. Only one "- " should be displayed:

-

Reopen the forward switch. The truck will either return to a normal operating state or a "-86" status code will appear on the dash display. If the "-86" code appears, the span voltage from minimum brake pedal displacement to full brake pedal displacement is less than 1 volt. This condition requires external adjustment to the brake pot prior to repeating the process above.

SECTION 9.0 MEMORY MAPS

Section 9.1 Typical Memory Map for Dual Motor Proportioning Controls

E ²	Func No.	HS No.	Traction Control Function	Access By	Restrictions
0	1	1	Mode Select	HS or PC	None
1	2	2	Creep Speed	HS or PC	None
2	3	3	Not Applicable	HS or PC	None
3	4	4	Armature Current Limit	HS or PC	None
4	5	5	Plugging Current Limit	HS or PC	None
5	6	6	Not Applicable	HS or PC	None
6	7	7	Not Applicable	HS or PC	None
7	8	8	Not Applicable	HS or PC	None
8	9	9	Not Applicable	HS or PC	None
9	10	10	Armature Current Ramp Down Rate	HS or PC	None
10	11	11	Turn Angle Pot Speed Limit	HS or PC	None
11	12	12	"Top Speed" Speed Limit	HS or PC	None
12	13	13	Not Applicable	HS or PC	None
13	14	14	Internal Resistance Compensation	HS or PC	None
14	15	15	Not Applicable	HS or PC	None
15	16	16	BDI Flash Level	HS or PC	None
16	17	17	Card Type Selection	HS or PC	None
17	18	18	Seat Timer	HS or PC	None
18	19	19	Not Applicable	HS or PC	None
19	20	20	Not Applicable	HS or PC	None
20	21	21	Auto Regen Current Limit	HS or PC	None
21	22	22	Autocalibration of Pots	HS or PC	For DD on power up
22	23	23	Not Applicable	HS or PC	None
23	24	24	Not Applicable	HS or PC	None
24	25	25	Monitor	HS or PC	GE Temporary Storage
25	26	26	Not Applicable	HS or PC	GE Temporary Storage
26	27	27	Not Applicable	HS or PC	GE Temporary Storage
27	28	28	Stored Status Code Count Pointer	HS or PC	None
28	29	29	Hours	HS or PC	None
29	30	30	Hours	HS or PC	None
30	31		Brake Pot Low Point	PC Only	None
31	32		Brake Pot High Point	PC Only	None
32	33	(18)	Not Applicable	PC Only	Reset to Zero Only
33	34		Not Applicable	PC Only	Reset to Zero Only
34	35		Not Applicable	PC Only	Reset to Zero Only
35	36		Not Applicable	PC Only	Reset to Zero Only
36	37	(20)	Not Applicable	PC Only	Reset to Zero Only
37	38		Not Applicable	PC Only	Reset to Zero Only
38	39		Not Applicable	PC Only	Reset to Zero Only
39	40		Not Applicable	PC Only	Reset to Zero Only
40	41	(22)	Not Applicable	PC Only	Reset to Zero Only
41	42		Not Applicable	PC Only	Reset to Zero Only
42	43		Not Applicable	PC Only	Reset to Zero Only
43	44		Not Applicable	PC Only	Reset to Zero Only

E ²	Func No.	HS No.	Traction Control Function	Access By	Restrictions
45	46		Not Applicable	PC Only	Reset to Zero Only
46	47		Not Applicable	PC Only	Reset to Zero Only
47	48		Not Applicable	PC Only	Reset to Zero Only
48	49	(26)	Not Applicable	PC Only	Reset to Zero Only
49	50		Not Applicable	PC Only	Reset to Zero Only
50	51		Not Applicable	PC Only	Reset to Zero Only
51	52		Not Applicable	PC Only	Reset to Zero Only
52	53	(28)	Not Applicable	PC Only	Reset to Zero Only
53	54		Not Applicable	PC Only	Reset to Zero Only
54	55		Not Applicable	PC Only	Reset to Zero Only
55	56		Not Applicable	PC Only	Reset to Zero Only
56	57	(30)	Not Applicable	PC Only	Reset to Zero Only
57	58		Not Applicable	PC Only	Reset to Zero Only
58	59		Not Applicable	PC Only	Reset to Zero Only
59	60		Not Applicable	PC Only	Reset to Zero Only
60	61	(32)	Not Applicable	PC Only	Reset to Zero Only
61	62		Not Applicable	PC Only	Reset to Zero Only
62	63		Not Applicable	PC Only	Reset to Zero Only
63	64		Not Applicable	PC Only	Reset to Zero Only
64	65	(34)	Not Applicable	PC Only	Reset to Zero Only
65	66		Not Applicable	PC Only	Reset to Zero Only
66	67		Not Applicable	PC Only	Reset to Zero Only
67	68		Not Applicable	PC Only	Reset to Zero Only
68	69	(36)	Not Applicable	PC Only	Reset to Zero Only
69	70		Not Applicable	PC Only	Reset to Zero Only
70	71		Not Applicable	PC Only	Reset to Zero Only
71	72		Not Applicable	PC Only	Reset to Zero Only
72	73	(38)	Not Applicable	PC Only	Reset to Zero Only
73	74		Not Applicable	PC Only	Reset to Zero Only
74	75		Not Applicable	PC Only	Reset to Zero Only
75	76		Not Applicable	PC Only	Reset to Zero Only
76	77	(40)	Not Applicable	PC Only	Reset to Zero Only
77	78		Not Applicable	PC Only	Reset to Zero Only
78	79		Not Applicable	PC Only	Reset to Zero Only
79	80		Not Applicable	PC Only	Reset to Zero Only
80	81	(42)	Not Applicable	PC Only	Reset to Zero Only
81	82		Not Applicable	PC Only	Reset to Zero Only
82	83		Not Applicable	PC Only	Reset to Zero Only
83	84		Not Applicable	PC Only	Reset to Zero Only
84	85	(44)	Not Applicable	PC Only	Reset to Zero Only
85	86		Not Applicable	PC Only	Reset to Zero Only
86	87		Not Applicable	PC Only	Reset to Zero Only
87	88		Not Applicable	PC Only	Reset to Zero Only
88	89	(46)	Not Applicable	PC Only	Reset to Zero Only
89	90		Not Applicable	PC Only	Reset to Zero Only
90	91		Not Applicable	PC Only	Reset to Zero Only
91	92		Not Applicable	PC Only	Reset to Zero Only

E ²	Func No.	HS No.	Traction Control Function	Access By	Restrictions
92	93	(48)	Not Applicable	PC Only	Reset to Zero Only
93	94		Not Applicable	PC Only	Reset to Zero Only
94	95		Not Applicable	PC Only	Reset to Zero Only
95	96		Not Applicable	PC Only	Reset to Zero Only
96	97	48	Mode 1 Control Acceleration	HS or PC	None
97	98	49	Mode 1 Field Weakening Start	HS or PC	None
98	99	50	Mode 1 Minimum Field	HS or PC	None
99	100	51	Mode 1 Ratio	HS or PC	None
100	101	52	Mode 1 Regen Current Limit	HS or PC	None
101	102	53	Mode 2 Control Acceleration	HS or PC	None
102	103	54	Mode 2 Field Weakening Start	HS or PC	None
103	104	55	Mode 2 Minimum Field	HS or PC	None
104	105	56	Mode 2 Ratio	HS or PC	None
105	106	57	Mode 2 Regen Current Limit	HS or PC	None
106	107	58	Mode 3 Control Acceleration	HS or PC	None
107	108	59	Mode 3 Field Weakening Start	HS or PC	None
108	109	60	Mode 3 Minimum Field	HS or PC	None
109	110	61	Mode 3 Ratio	HS or PC	None
110	111	62	Mode 3 Regen Current Limit	HS or PC	None
111	112	63	Brake Fault Multiplier	PC Only	None
112	113		Not Applicable	PC Only	OEM Read Only
113	114		Not Applicable	PC Only	OEM Read Only
114	115		Not Applicable	PC Only	OEM Read Only
115	116		Not Applicable	PC Only	OEM Read Only
116	117		GE Use	PC Only	OEM Read Only
117	118		GE Use	PC Only	OEM Read Only
118	119		GE Use	PC Only	OEM Read Only
119	120		GE Use	PC Only	OEM Read Only
120	121		Control Acceleration Clamp	PC Only	None
121	122		FW Start Clamp	PC Only	None
122	123		Minimum Field Clamp	PC Only	None
123	124		Ratio Clamp	PC Only	None
124	125		Regen C/L Clamp	PC Only	None
125	126		Turn Pot Offset	PC Only	None
126	127		Re-scaled All Slope	PC Only	None
127	128		Re-scaled All Y-Int	PC Only	None

Numbers in **(bold italics)** are Stored Status Code pointers.