

Curtis 1510(A)

This sheet is provided to aid in the installation of your remanufactured CURTIS controller. Upon installation, you may encounter problems that may, or may not, be due to a faulty controller. The following steps must be taken to help diagnose a possible cart fault or faulty controller. An analog or digital volt ohm meter (VOM) will be needed to perform these checks.



WARRANTY WILL BE VOID **If These Steps are Not Performed Before Installing The Control**

➔ STEPS TO PERFORM *BEFORE* CONTROL INSTALLATION ←

CHECK MOTOR WINDINGS:

- Set your VOM to RESISTANCE (Ω).
- With your motor disconnected, measure A1 to A2. This must measure BETWEEN $.3\Omega$ and 1Ω .
- With your motor disconnected, measure F1 to F2. This must measure BETWEEN 1Ω and 2Ω .
- With your motor disconnected, measure A1 to F1. This must measure OPEN.
- With your motor disconnected, measure F1 to motor case. This must measure greater than $5M\Omega$.

CHECK MAIN SOLENOID:

- Disconnect all wires from the main solenoid.
- Set your VOM to RESISTANCE (Ω).
- Measure the solenoid coil. This must measure NO LESS than 100Ω .
- Connect VOM leads to the main solenoid lugs.
- Attach jumpers from main battery positive and negative to the coil (small terminals).
- Meter must jump from infinity to LESS THAN $.3\Omega$.
- Remove jumpers and reconnect solenoid wiring from the harness. (If suppression diode is present, The non-banded side must go to the blue/white wire – pin 12 from controller.)

CHECK THE CART WIRE HARNESS:

- Check the connectors on the wire harness for corrosion, loose, broken, burnt or missing pins.
- Repair or replace pins as necessary.

**IF ANY OF THE ABOVE ITEMS ARE NOT WITHIN THE SPECIFIED RANGES THE CONTROLLER WILL FAIL.
THESE ITEMS MUST BE CORRECTED BEFORE THE CONTROLLER IS INSTALLED OR WARRANTY WILL BE VOID.**

It is recommended to replace your solenoid at the time of controller replacement. FSIP now stocks popular replacement White Rodgers solenoids for your convenience.

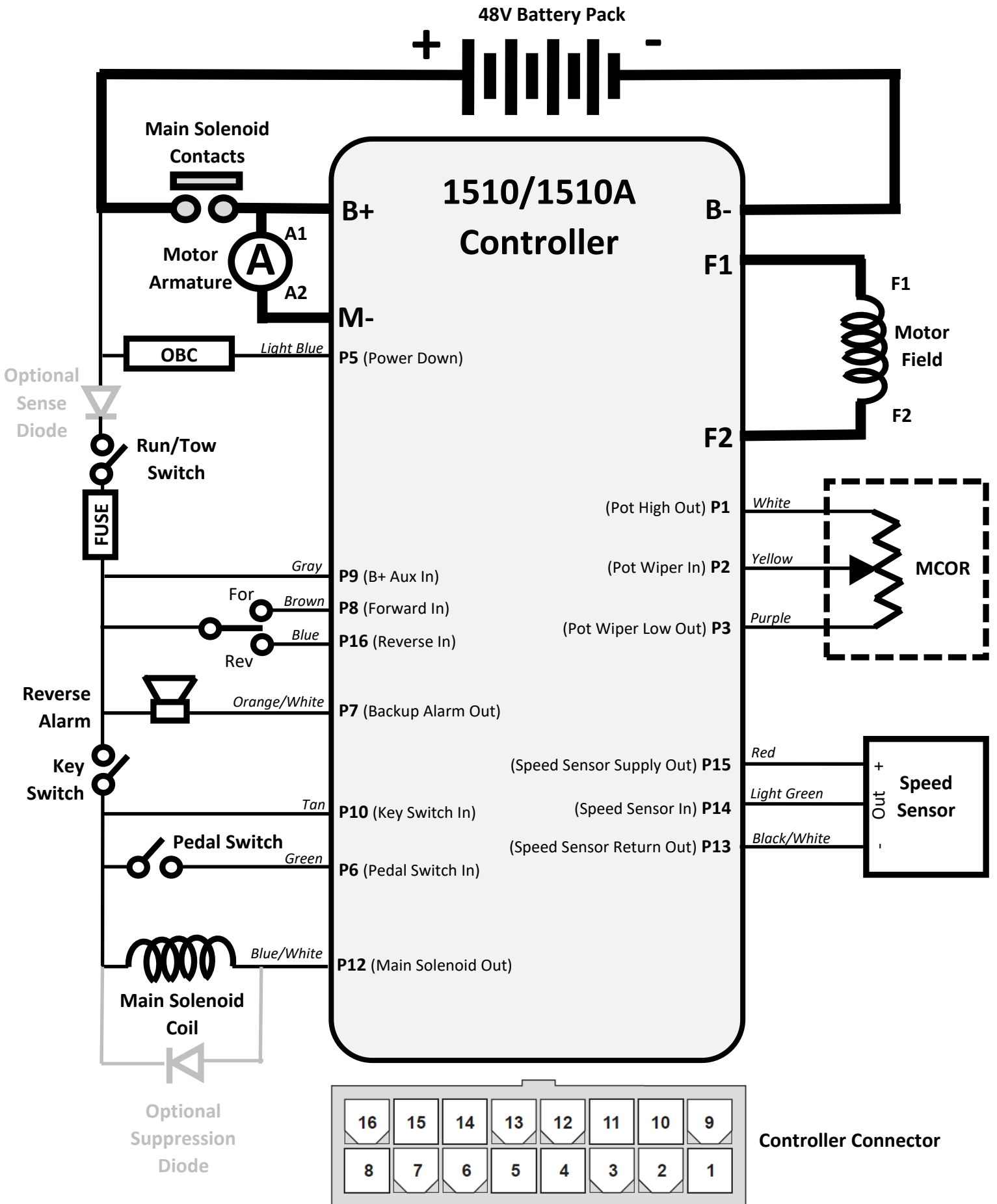

Club Car Precedent (IQ) Troubleshooting Sequence

FOR SAFETY, ALWAYS LIFT THE DRIVE WHEELS OFF THE GROUND WHEN TROUBLESHOOTING!

ALL TESTS ARE CONDUCTED WITH RUN-TOW/MAINTENANCE SWITCH IN THE RUN POSITION AND WITH A GOOD BATTERY PACK VOLTAGE MEASUREMENT. ALSO, THE CONNECTOR MUST BE ATTACHED TO THE CONTROLLER WHEN MAKING THESE CHECKS. YOU WILL NEED TO 'BACK PROBE' THE PINS FROM THE WIRE SIDE OF THE CONNECTOR. USE A PAPERCLIP IF NECESSARY.

Attach voltmeter negative (-) lead to main battery – for the following tests

Use the following sequence when checking individual pins (don't skip steps). **If you find a fault, do not move on to the next step until the fault is corrected:**

- Measure the voltage at the main battery positive post (let's call it Pack Voltage)
- Pin 5 With charger disconnected**, must be greater than 30V (if less than 30V this control will be dead)
 - *If not, your OBC may be in sleep mode. Put your cart on charge for 1 minute, disconnect then recheck. If you still do not have more than 30V at this pin, you may have an OBC issue*
- Pin 9** Must be equal to Pack Voltage
 - *If not Pack Voltage, check wiring, Sense Diode (if present), Run-Tow/Maintenance Switch or Fuse*
- Pin 8 With F/R Switch in Reverse**, must equal 0 volts
 - *If not 0 volts, check wiring and F/R Switch for a shorted condition*
- Pin 8 With F/R Switch in Forward**, must equal Pack Voltage
 - *If not Pack Voltage, check wiring and F/R Switch for an open condition*
- Pin 16 With F/R Switch in Forward**, must equal 0 volts
 - *If not 0 volts, check wiring and F/R Switch for a shorted condition*
- Pin 16 With F/R Switch in Reverse** must equal Pack Voltage
 - *If not Pack Voltage, check wiring and F/R Switch for an open condition*
- Pin 7** Must equal Pack Voltage
 - *If not Pack Voltage, check wiring and Reverse Alarm for an open condition*
- Pin 10 With Key Off**, must equal 0 volts
 - *If not 0 volts, check Key Switch for short condition*
- Pin 10 With Key On**, must equal Pack Voltage
 - *If not Pack Voltage, check Key Switch for open condition*
- Pin 6 With Pedal Up**, must equal 0 volts
 - *If not 0 volts, check wiring and Pedal Switch for a shorted condition*
- Pin 6 With Pedal Down**, must equal Pack Voltage
 - *If not Pack Voltage, check wiring and Pedal Switch for an open condition*
- Pin 12** Must equal Pack Voltage
 - *If not Pack Voltage, check wiring and Main Solenoid Coil for an open condition*
- Pin 1** Must equal 5 volts
 - *If not 5 volts, check wiring and check with MCOR removed – if voltage goes to 5 volts, replace MCOR*
- Pin 2 With Pedal Up**, must equal 0 volts
 - *If not 0 volts, check wiring and MCOR*

Continued on next page ...

- **Pin 2** *With Pedal Down*, must equal 5 volts
 - *If not 5 volts, check wiring and MCOR*
- **Pin 3** Must equal 0 volts
 - *If not 0 volts, harness and/or harness connector is defective, check wiring*
- **Pin 15** Must equal 15 volts
 - *If not 15 volts, check wiring and check with Speed Sensor removed – if voltage goes to 15 volts, replace Speed Sensor*
- **Pin 14** *While slowly turning the drive wheel*, must toggle between 0 volts and 5 volts
 - *If not toggling, check wiring and if necessary replace Speed Sensor*

Helpful Hints

- If the cart is in limp mode (traveling less than 8MPH), and a Sense Diode is present in your vehicle, check the diode for continuity. If the diode has continuity in both directions, it is defective. In this case, the controller senses a Main Welded condition and places the cart in limp mode. Replace the Sense Diode with Club Car part number 102576801. This diode, if present, will be located near the Run/Tow Switch.
- **DO NOT UNDER ESTIMATE THE IMPORTANCE OF MOTOR RESISTANCE CHECKS AND MAIN SOLENOID CHECKS. MANY CART ISSUES ARE CAUSED BY BURNT/DAMAGED BRUSHES THAT WILL BE FOUND AS PART OF THE ARMATURE RESISTANCE CHECK. ALSO A SHORTED ARMATURE AND FIELD WITHIN THE MOTOR WILL DAMAGE THIS CONTROLLER.**

Flight Systems Industrial Products also offers the following Technical Support options ...



Troubleshooting Manuals / Codes
www.fsip.biz/TroubleshootingManuals.html



Live Tech Support Chat
www.fsip.biz



Technical Support Forum
fsip.websitetoolbox.com



Frequently Asked Questions
www.fsip.biz/FAQ.html

Phone Support
 1-800-333-1194 (Option 4)

**PRE-INSTALLATION
 INSTRUCTIONS MUST BE
 FOLLOWED OR WARRANTY
 WILL BE VOID**

IMPORTANT!
CLUB CAR PRECEDENT IQ
TROUBLESHOOTING INFORMATION
INCLUDED IN THIS PACKET