

**SEPARATELY EXCITED (SX) TRANSISTORIZED MOTOR CONTROLLERS
 FOR NEIGHBORHOOD ELECTRIC VEHICLE APPLICATION**

INSTALLATION AND OPERATION MANUAL

(GE MODEL IC3645SH7R354D2)

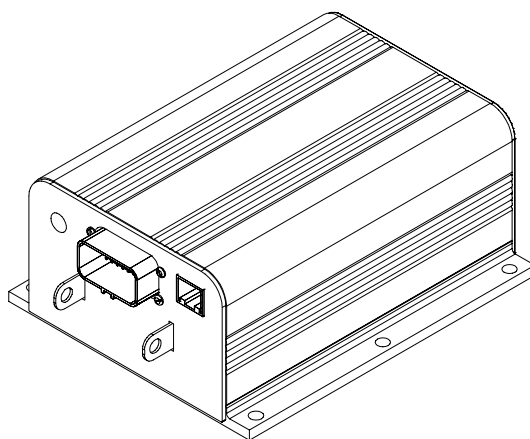

Note: The information contained herein is intended to assist OEM's, Dealers and Users of electric vehicles in the application, installation and service of GE solid-state controllers. This manual does not purport to cover all variations in OEM vehicle types. Nor does it provide for every possible contingency to be met involving vehicle installation, operation or maintenance. For additional information and/or problem resolution, please refer the matter to the OEM vehicle manufacturer through his normal field service channels. Do not contact GE directly for this assistance.

General Electric Company April 2002

Table of Contents

Section 1.0	INTRODUCTION	3
1.1	Motor Characteristics	3
1.2	Solid-State Reversing	4
1.3	Flexible System Application.....	4
1.4	More Features with Fewer Components.....	4
Section 2.0	FEATURES OF SX FAMILY OF MOTOR CONTROLLERS	5
2.1	Performance.....	5
2.1.1	Oscillator Card Features	5
2.1.1.a	Standard Operation.....	5
2.1.1.b	Control Acceleration	5
2.1.2	Current Limit	5
2.1.3	Plug Braking	5
2.1.4	Regenerative Braking to Base Speed.....	5
2.1.5	Auxiliary Speed Control.....	5
2.1.5.a	Field Weakening.....	5
2.1.5.b	Speed Limits	5
2.1.5.c	Top Speed Regulation	6
2.1.6	Ramp Start	6
2.1.7	On-Board Coil Drivers and Internal Coil Suppression	6

Table of Contents (Continued)

2.2	System Protective Override	6
2.2.1	Start Switch Check	6
2.2.2	Accelerator Volts Hold Off.....	6
2.2.3	Pulse Monitor Trip (PMT).....	6
2.2.4	Thermal Protector (TP).....	6
2.2.5	Low Voltage	6
2.3	Diagnostics.....	6
2.3.1	Status Codes.....	6
2.3.1.a	Standard Status Codes.....	6
2.3.1.b	Stored Status Codes	7
2.3.2	Hourmeter Readings	7
2.3.3	Dash Display Routine and Battery Discharge Indication (BDI).....	7
2.3.4	Internal Resistance Compensation	7
2.3.5	Handset	7
2.3.6	RS-232 Communication Port	7
2.3.7	Circuit Board Coil Driver Modules.....	7
Section 3.0	ORDERING INFORMATION, ELEMENTARY AND OUTLINE DRAWINGS.....	8
3.1	Ordering Information for Separately Excited Controls.....	8
3.2	Outline: SX-2 Package Size.....	9
3.3	Standard Elementary for NEV Application	10
3.4	Standard NEV Application Input/Output List.....	11
Section 4.0	TROUBLESHOOTING AND DIAGNOSTIC STATUS CODES.....	12
4.1	General Maintenance Instructions.....	12
4.2	Cable Routing and Separation	12
4.2.1	Application Responsibility	12
4.2.2	Signal/Power Level Definitions	12
4.2.2.a	Low Level Signals (Level L).....	12
4.2.2.b	High Level Signals (Level H).....	13
4.2.2.c	Medium-Power Signals (Level MP)	13
4.2.2.d	High-Power Signals (Level HP)	13
4.2.3	Cable Spacing Guidelines	13
4.2.3.a	General Cable Spacing.....	13
4.2.4	Cabling for Vehicle Retrofits.....	13
4.2.5	RF Interference.....	13
4.2.6	Suppression.....	13
4.3	Recommended Lubrication of Pins and Sockets Prior to Installation.....	14
4.4	General Troubleshooting Instructions	15
4.5	Traction Controller Status Codes	16-28
Section 5.0	SX FAMILY - GE HANDSET INSTRUCTIONS	29
5.1	General Features	29
5.2	Purpose/Setup Functions	29
5.3	Setup Function Procedures	30
5.3.1	Setup Mode	30
5.3.2	Status Code Scrolling.....	30
5.3.3	SX Handset Plug Connections and Outline Drawing.....	30
5.4	Setup Functions for Traction Controller	31-35
5.5	Summary of Current Limit Adjustments.....	36
Section 6.0	MEMORY MAP.....	37-39

Section 1. INTRODUCTION

Section 1.1 Motor Characteristics

The level of sophistication in the controllability of traction motors has changed greatly over the past several years. Vehicle manufacturers and users are continuing to expect more value and flexibility in electric vehicle motor and control systems as they are applied today. In order to respond to these market demands, traction system designers have been forced to develop new approaches to reduce cost and improve functions and features of the overall system. Development is being done in a multi-generational format that allows the market to take advantage of today's technology, while looking forward to new advances on the horizon. GE has introduced a second generation system using separately excited DC shunt wound motors. The separately excited DC motor system offers many of the features that are generally found on the advanced AC systems. Historically, most electric vehicles have relied on series motor designs because of their ability to produce very high levels of torque at low speeds. But, as the demand for high efficiency systems increases, i.e., systems that are more closely applied to customers' specific torque requirements, shunt motors are now often being considered over series motors. In most applications, by independently controlling the field and armature currents in the separately excited motor, the best attributes of both the series and the shunt wound motors can be combined.

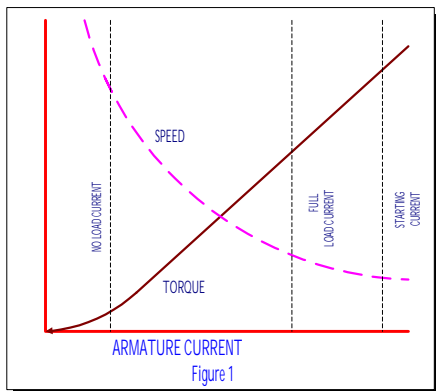

As shown in the typical performance curves of Figure 1, the high torque at low speed characteristic of the series motor is evident.

In a shunt motor, the field is connected directly across the voltage source and is therefore independent of variations in load and armature current. If field strength is held constant, the torque developed will vary directly with the armature current. If the mechanical load on the motor increases, the motor slows down, reducing the back EMF (which depends on the speed, as well as the constant field strength). The reduced back EMF allows the armature

current to increase, providing the greater torque needed to drive the increased mechanical load. If the mechanical load is decreased, the process reverses. The motor speed and the back EMF increase, while the armature current and the torque developed decrease. Thus, whenever the load changes, the speed changes also, until the motor is again in electrical balance.

In a shunt motor, the variation of speed from no load to normal full load on level ground is less than 10%. For this reason, shunt motors are considered to be constant speed motors (Figure 2).

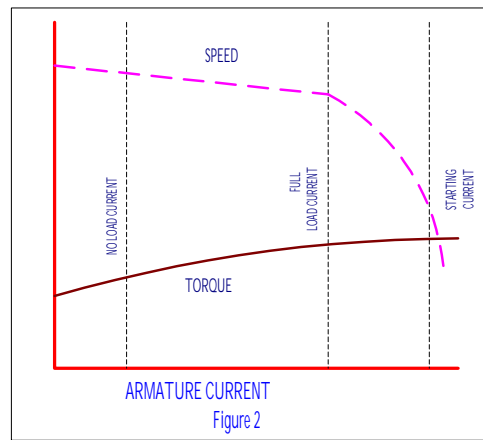

In the separately excited motor, the motor is operated as a fixed field shunt motor in the normal running range. However, when additional torque is required, for example, to climb non-level terrain, such as ramps and the like, the field current is increased to provide the higher level of torque. In most cases, the armature to field ampere turn ratio can be very similar to that of a comparable size series motor (Figure 3.)

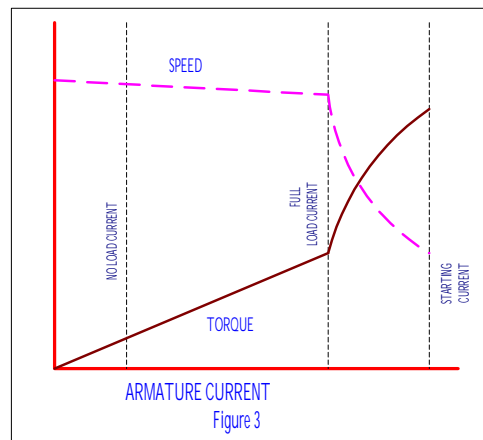

Aside from the constant horsepower characteristics described above, there are many other features that provide increased performance and lower cost. The following description provides a brief introduction to some of these features.

Section 1. 2 Solid-State Reversing

The direction of armature rotation on a shunt motor is determined by the direction in which current flows through the field windings. Because the shunt motor field typically only requires about 10% of the armature current at full torque, it is normally cost effective to replace the double-pole, double-throw reversing contactor with a low power transistor H-Bridge circuit (Figure 4).

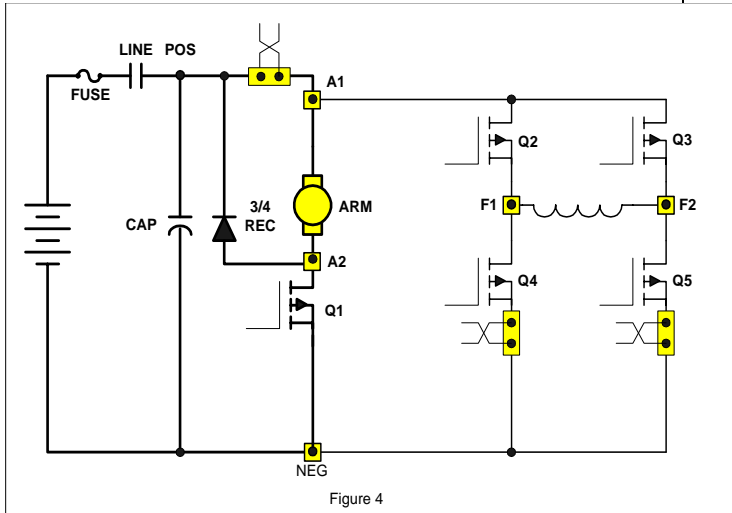

Figure 4

By energizing the transistors in pairs, current can be made to flow in either direction in the field. The field and armature control circuits typically operate at 12KHZ to 15KHZ, a frequency range normally above human hearing. This high frequency, coupled with the elimination of directional contactors, provides for very quiet vehicle operation.

The line contactor is normally the only contactor required for the shunt motor traction circuit. This contactor is used for both pre-charge of the line capacitors and for emergency shut down of the motor circuit, in case of problems that would cause a full motor torque condition. The line can be energized and de-energized by the various logic combinations of the vehicle, i.e. activate on key, seat or start switch closure, and de-energize on time out of idle vehicle. Again, these options add to the quiet operation of the vehicle.

Section 1. 3 Flexible System Application

Because the shunt motor controller has the ability to control both the armature and field circuits independently, the system can normally be adjusted for maximum system efficiencies at certain operating parameters. Generally speaking, with the ability to independently control the field

and armature, the motor performance curve can be maximized through proper control application.

Section 1. 4 More Features with Fewer Components

Field weakening with a series wound motor is accomplished by placing a resistor in parallel with the field winding of the motor. Bypassing some of the current flowing in the field into the resistor causes the field current to be less, or weakened. With the field weakened, the motor speed will increase, giving the effect of "overdrive". To change the "overdrive speed", it is necessary to change the resistor value. In a separately excited motor, independent control of the field current provides for infinite adjustments of "overdrive" levels, between the motor base speed and maximum weak field. The desirability of this feature is enhanced by the elimination of the contactor and resistor required for field weakening with a series motor.

With a separately excited motor, overhauling speed limit, or downhill speed, will also be more constant. By its nature, the shunt motor will try to maintain a constant speed downhill. This characteristic can be enhanced by increasing the field strength with the control. Overhauling load control works in just the opposite way of field weakening, as armature rotation slows with the increase of current in the field. An extension of this feature is a zero-speed detect feature

which prevents the vehicle from free-wheeling down an incline, should the operator neglect to set the brake.

Regenerative braking (braking energy returned to the battery) may be accomplished completely with solid-state technology. The main advantage of regenerative braking is increased motor life. Motor current is reduced by 50% or better during braking while maintaining the same braking torque as electrical braking with a diode clamp around the armature. The lower current translates into longer brush life and reduced motor heating. Solid state regenerative braking also eliminates a power diode, current sensor and contactor from the circuit.

For GE, the future is now, as we make available a new generation of electric traction motor systems for electric vehicles having separately excited DC shunt motors and controls. Features that were once thought to be only available on future AC or brushless DC technology vehicles systems are now achievable and affordable.

Section 2. FEATURES OF SX FAMILY OF TRANSISTOR MOTOR CONTROLLERS

Section 2.1 Performance

Section 2.1.1 Oscillator Card Features

Section 2.1.1.a Standard Operation

The oscillator section of the card has two adjustable features, creep speed and minimum field current. With the accelerator at maximum ohms or volts, the creep speed can be adjusted by Function 2 of the Handset or a trimpot. The field control section allows the adjustment of the field weakening level in order to set the top speed of the motor. This top speed function (Minimum Field Current) is enabled when the armature current is less than the value set by Function 24 and the accelerator input voltage is less than 1 volt. Top Speed can be adjusted by Function 7 of the Handset or a trimpot.

The % ON-time has a range of approximately 0 to 100 percent. The SX controllers operate at a constant frequency and the % ON-time is controlled by the pulse width of the voltage/current applied to the motor circuits.

Section 2.1.1.b Control Acceleration

This feature allows for adjustment of the rate of time it takes for the control to accelerate to 100% applied battery voltage to the motor on hard acceleration. Armature C/A is adjusted by Function 3 from 0.1 to 22 seconds.

Section 2.1.2 Current Limit

This circuit monitors motor current by utilizing sensors in series with the armature and field windings. The information detected by the sensor is fed back to the card so that current may be limited to a preset value. If heavy load currents are detected, this circuit overrides the oscillator and limits the average current to a value set by Function 4 and Function 8 of the Handset. The C/L setting is based on the maximum thermal rating of the control. Because of the flyback current through 3REC, the motor current is usually greater than battery current, except at 100% ON time.

Section 2.1.3 Plug Braking

Slow down is accomplished when reversing direction by providing a small amount of retarding torque for deceleration. If the vehicle is moving, and the directional lever is moved from one direction to the other, the plug signal is initiated. Once the plug signal has been initiated, the field is reversed, and the armature current is regulated to the plug current limit. Armature current is regulated by increasing the field current as the vehicle slows down. Once the field current reaches a preset value, set by Function 10, and armature plug current can no longer be maintained, the braking function is canceled, and the control reverts back to motoring.

All energy produced by the motor during plugging is dumped as heat in the motor in this braking mode.

Section 2.1.4 Regenerative Braking to Base Speed

Regenerative braking to base speed is a function of the vehicle motor design which slows the vehicle to a speed corresponding to the base speed of the motor whenever the start switch is opened or the control detects an overspeed condition. The field FETs pulse on/off to regulate the armature current. During regen, armature current is allowed to flow from the armature through the current sensor, the battery, the armature transistor and back to the armature. All regen current is returned to the battery. Regen current will continue to flow until the speed of the motor drops below its base speed, at which point the vehicle will coast.

Section 2.1.5 Auxiliary Speed Control

Section 2.1.5.a Field Weakening

This function allows the adjustment of the field weakening level in order to set the top speed of the motor. The function is enabled when the armature current is less than the value set by Function 24. It is important to note that this function is used to optimize motor and control performance, and this setting will be determined by GE and OEM engineers at the time of vehicle development. *This setting must not be changed by field personnel without the permission of the OEM.*

Section 2.1.5.b Speed Limits

This feature provides a means to limit motor speed by controlling the armature voltage. The speed limit setting provides a clamp on the accelerator voltage command, limiting the conduction period of the armature FET's.

There are two speed limit settings, reverse speed limit and turf speed limit. When the reverse direction is selected, pin 5 is high, and the reverse speed limit will be used and the turf switch is not checked by software. When the forward direction is selected, pin 4 is high. The turf speed limit will be enabled if the turf speed switch input, pin 6, is low.

The voltage to the motor armature will vary as a function of the speed limit settings and the battery volts. The motor speed will vary as a function of load and battery volts.

Section 2.1.5.c Top Speed Regulation

This feature requires a system tachometer. The standard GE system tach is built into the motor and provides four pulses per armature revolution. Once the control has been calibrated to the vehicle parameters (gear ratio and wheel rolling radius), using Function 1, speed can be measured with a resolution of +/- 1 mph. When traveling

down an incline, if the vehicle speed increases to the over speed setting, the control automatically transitions to the regen mode. The maximum incline on which the control will be able to maintain regulation is determined by the characteristics of the motor, the maximum regen armature current limit setting (Function 9), and the maximum regen field current limit setting (Function 10).

When the vehicle reaches the bottom of the incline, and the vehicle speed decreases below the over speed setting on the level surface, the control automatically transitions back to the normal running mode.

Section 2.1.6 Ramp Start

This feature provides maximum control torque to restart a vehicle on an incline. The memory for this function is the directional switch. When stopping on an incline, the directional switch must be left in its original or neutral position to allow the control to initiate full power when restarted. The accelerator potentiometer input will modulate ramp start current.

Section 2.1.7 On-Board Coil Drivers and Internal Coil Suppression

A coil driver for the LINE contactor is on-board the control card. This contactor must have a coil rated for the vehicle battery volts, with a maximum current of 1 amp.

Section 2.2 System Protective Override

Section 2.2.1 Start Switch Check

If the key switch is opened, the control shuts off and cannot be restarted until the start switch opens (see Status Code –11, described in Section 4.5 of this manual).

Section 2.2.2 Accelerator Volts Hold Off

This feature checks the voltage level at the accelerator input whenever the key switch is activated. If, at key on, the voltage is greater than 1.24 volts, the control will not operate. This feature assures that the control is calling for low speed operation at start up (see Status Code –8, described in Section 4.5 of this manual).

Section 2.2.3 Pulse Monitor Trip (PMT)

The PMT design contains three features which shut down, or lock out, control operation if a fault conditions occurs that would cause a disruption of normal vehicle operation:

- Look ahead
- Look again
- Automatic look again and reset

The PMT circuit will not allow the control to start under the following conditions:

- The control monitors armature FET's at start-up and during running.
- The control will not allow the line contactor to close at start-up, or will drop it out during running, if the armature FET's are of low resistance, so as to cause uncontrolled vehicle movement.

Section 2.2.4 Thermal Protector (TP)

This temperature sensitive device is internal to the power transistor (Q1) module. If the transistor's temperature begins to exceed the design limits, the thermal protector will lower the maximum current limit, and maintain the transistors within their temperature limits. As the control cools, the thermal protector will automatically reset, returning the control to full power.

Section 2.2.5 Low Voltage

Batteries under load, particularly if undersized or more than 80 percent discharged, will produce low voltages at the control terminals. The SX control is designed for use down to 50 percent of a nominal battery voltage of 36-84 volts, and 75 percent of a nominal battery voltage of 24 volts. Lower battery voltage may cause the control to operate improperly, however, the resulting PMT should open the Line contactor, in the event of a failure.

Section 2.3 Diagnostics

The control detects the system's present operating status and this status can be displayed to either the Dash Display or the Handset.

Section 2.3.1 Status Codes

Section 2.3.1a Standard Status Codes

The SX control has a wide variety of Status Codes that assist the service technician and operator in trouble shooting the vehicle. If mis-operation of the vehicle occurs, a status code will be displayed on the Dash Display for vehicles so equipped, or be available from the status code displayed when the Handset is plugged into the "Y" plug of the logic card.

With the status code number, follow the procedures outlined in DIAGNOSTIC STATUS CODES to determine the problem and appropriate corrective action.

Note: The Status Code Instruction Sheets do not purport to cover all possible causes of a display of a "status code". They do provide instructions for checking the most direct inputs that can cause status codes to appear.

Section 2.3.1.b Stored Status Codes

This feature records the last 16 "Stored Status Codes" that have caused a PMT controller shut down and/or disrupted normal vehicle operation. (PMT type faults are reset by cycling the key switch). These status codes, along with the corresponding BDI and hourmeter readings, can be accessed with the Handset, or by using the RS 232 communications port and dumping the information to a Personal Computer terminal.

Section 2.3.2 Hourmeter Readings

This feature will display the recorded hours of use of the traction control to the Dash Display (if used) each time the key switch is turned off.

Section 2.3.3 Dash Display Routine and Battery Discharge Indication (BDI)

The latest in microprocessor technology is used to provide accurate battery state of charge information and to supply passive and active warning signals to the vehicle operator. The control outputs a signal for dash display to display the vehicle speed in MPH once every 0.1 seconds for 9.5 seconds. After that point, the dash display shows the battery discharge indicator value once.

Section 2.3.4 Internal Resistance Compensation

This feature is used when the Battery Discharge Indicator is present. Adjustment of this function will improve the accuracy of the BDI.

Section 2.3.5 Handset

This is a multi-functional tool used with the LX, ZX, and SX Series GE solid state controls. The Handset consists of a Light Emitting Diode (LED) display and a keyboard for data entry.

Features and functions:

- Monitor existing system status codes for traction controls. Monitor intermittent random status codes.
- Monitor battery state of charge, if available.

- Monitor hour meter reading on traction controls. Monitor or adjust the control functions.

Section 2.3.6 RS 232 Communication Port

This serial communication port displays the vehicle speed in MPH nine times, and then flashes a Status Code -90, once, if the motor is overheating. Refer to Section 4.5 of this manual, for additional description of Status Code -90. If the motor is not overheating, the BDI value will be displayed once, in place of Status Code -90 output.

The serial port also provides service personnel with access to operating information and control settings via a personal computer.

Section 2.3.7 Circuit Board Coil Driver Modules

Coil drivers are internal to the control card, and are the power devices that operate the Line contactor coils. On command from the control card, these drivers initiate opening and closing the contactor coils. All driver modules are equipped with reverse battery protection, such that, if the battery is connected incorrectly, the contactors cannot be closed electrically.

Section 3.0 ORDERING INFORMATION, ELEMENTARY AND OUTLINE DRAWINGS

Section 3.1 Ordering Information for Separately Excited Controls

Example:

Part Number:	IC3645	SH	4	D	33	2	C3
Argument Number:	01	02	03	04	05	06	07

Argument 01: Basic Electric Vehicle Control Number

Argument 02: Control Type:
 SH = Separately Excited Control (Plugging)
 SR = Separately Excited Control (Regen to Zero)

Argument 03: Operating Voltage:

1 = 120 volts	5 = 36/48 volts
2 = 24 volts	6 = 24/36 volts
3 = 36 volts	7 = 72/80 volts
4 = 48 volts	

Argument 04: Package Size:

D = 6.86" X 6.67"
R = 6.86" X 8.15"
U = 8.66" X 8.13"
W = 8.66" X 10.83"

Argument 05: Armature Current
 (2 characters)

22 = 220 Amps
33 = 330 Amps
40 = 400 Amps

etc.

Argument 06: Field Current
 (1 character)

2 = 20 Amps
3 = 30 Amps
4 = 40 Amps

etc.

Argument 07: Customer / Revision

A1 = Customer A / Revision 1
B1 = Customer B / Revision 1

etc.

Section 3.2 Outline: SX-2 Package Size

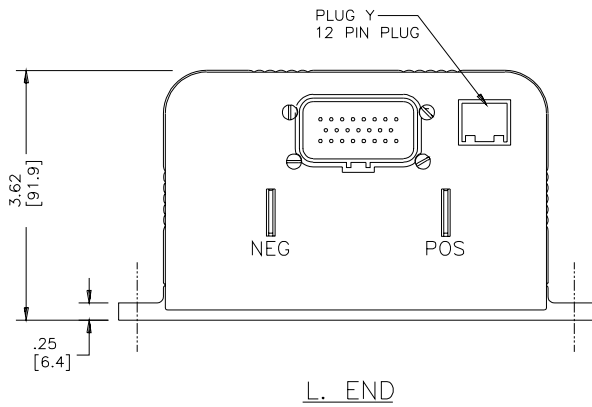
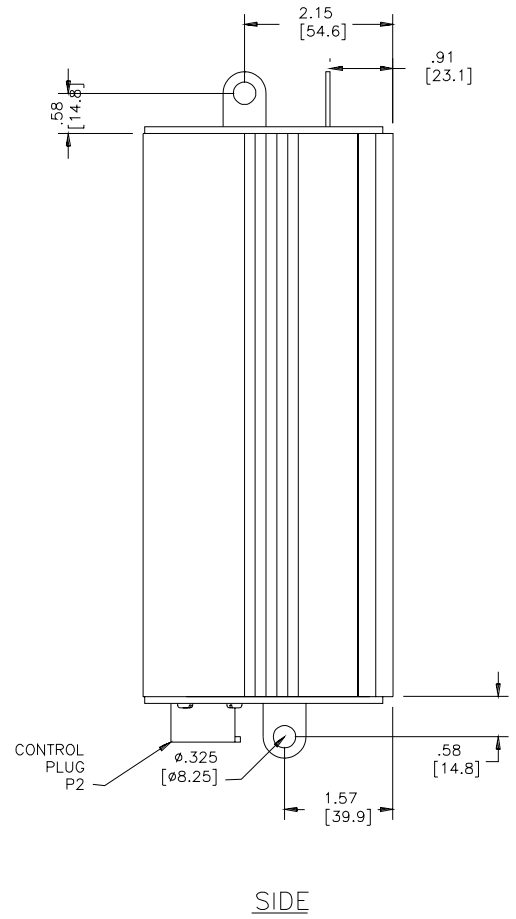
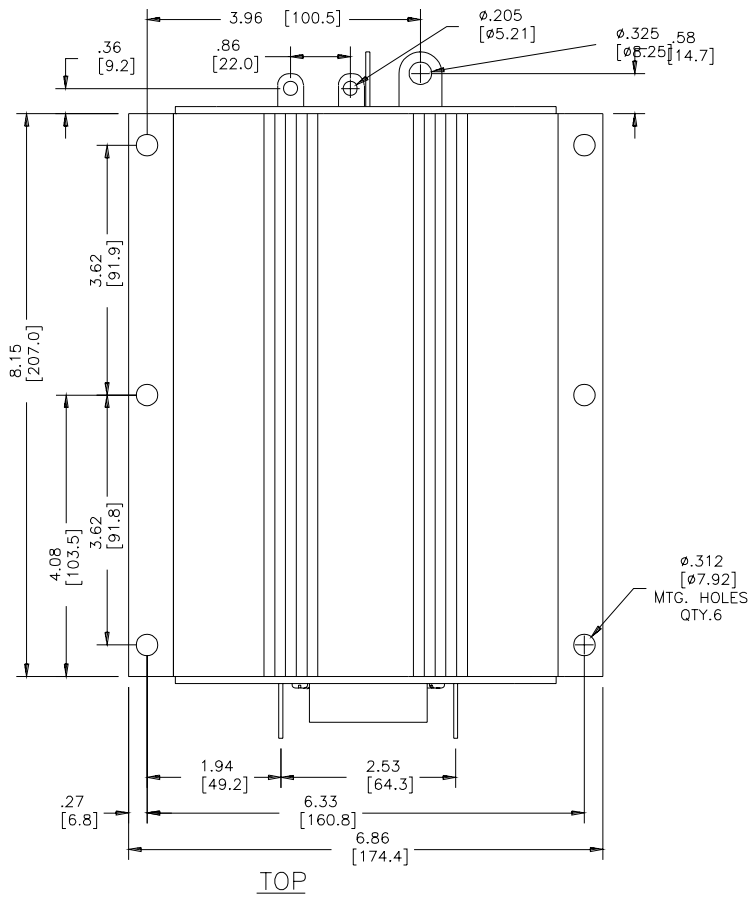

Section 3.3 Standard Elementary for Neighborhood Electric Vehicle Application

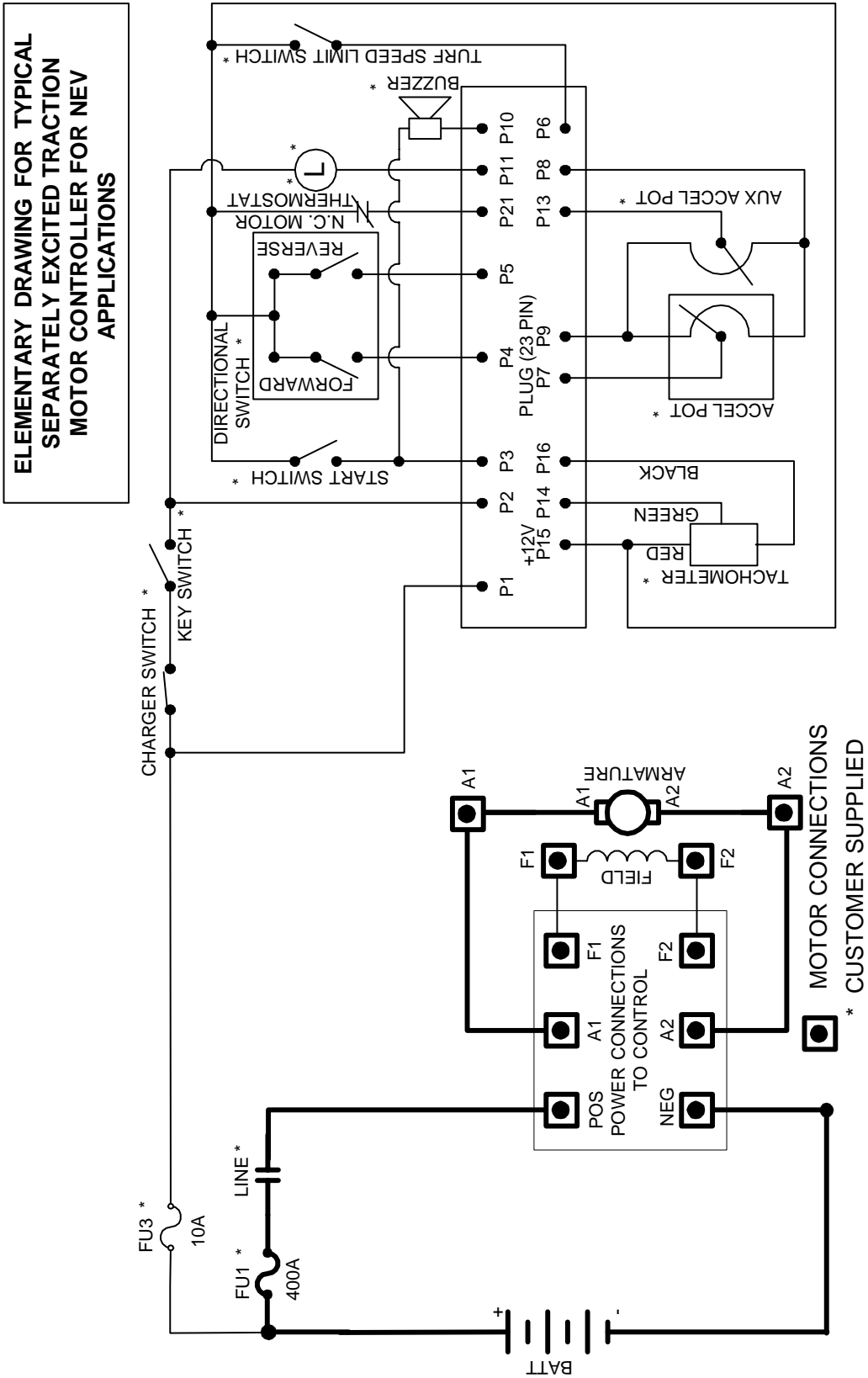

Section 3.4 Standard Neighborhood Electric Vehicle Application Input/Output List

Connections to Main Plug (23 Pin) and "Y" Plug (8 Pin)

PIN	MAIN PLUG INPUT/OUTPUT DESCRIPTION
1	BATTERY VOLTS FROM BATTERY
2	BATTERY VOLTS FROM KEY
3	12 VOLT INPUT FROM ACCELERATOR START SWITCH
4	12 VOLT INPUT FROM FORWARD SWITCH
5	12V VOLT INPUT FROM REVERSE SWITCH
6	12V VOLT INPUT FROM TURF SPEED LIMIT SWITCH
7	ACCELERATOR INPUT VOLTAGE SIGNAL
8	BATTERY NEGATIVE FOR CONTROL ACCESSORIES
9	ACCELERATOR POT +5 VOLTS SUPPLY (3 WIRE POT)
10	BACK UP ALARM
11	LINE CONTACTOR COIL DRIVER
12	N/A
13	AUXILIARY ACCELERATOR POT INPUT
14	TACHOMETER INPUT SIGNAL
15	TACHOMETER 12 VOLT OUTPUT
16	NEGATIVE FOR TACH
17	N/A
18	N/A
19	N/A
20	N/A
21	NORMALLY CLOSED MOTOR THERMOSTAT
22	SERIAL RECEIVE
23	SERIAL TRANSMIT
PIN	"Y" PLUG INPUT/OUTPUT DESCRIPTION
1	CLOCK (OUT)
2	DATA (OUT)
3	ENABLE (OUT)
4	NEGATIVE
5	+5V SUPPLY
6	STORE (IN) (HANDSET)
7	I _M OUTPUT
8	VALUE
9	FUNCTION
10	N/A
11	SERIAL RECEIVE
12	SERIAL TRANSMIT

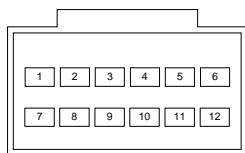

WIRE END VIEW "Y" PLUG

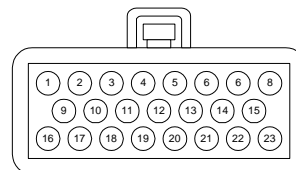

WIRE END VIEW - MAIN PLUG

Section 4.0 TROUBLESHOOTING AND DIAGNOSTIC STATUS CODES

Section 4.1 General Maintenance Instructions

The transistor control, like all electrical apparatus, does have some thermal losses. The semiconductor junctions have finite *temperature* limits, above which these devices may be damaged. For these reasons, normal maintenance should guard against any action which will expose the components to excessive heat and/or those conditions which will reduce the heat dissipating ability of the control, such as restricting air flow.

The following Do's and Don't's should be observed:

Any controls that will be applied in ambient temperatures over 100° F (40° C) should be brought to the attention of the vehicle manufacturer.

All external components having inductive coils must be filtered. Refer to vehicle manufacturer for specifications.

The wiring should not be directly steam cleaned. In dusty areas, blow low-pressure air over the control to remove dust. In oily or greasy areas, a mild solution of detergent or denatured alcohol can be used to wash the control, and then low-pressure air should be used to completely dry the control.

For the control to be most effective, it must be mounted against the frame of the vehicle. The metal vehicle frame, acting as an additional heat sink, will give improved vehicle performance by keeping the control package cooler. *Apply a thin layer of heat-transfer grease (such as Dow Corning 340) between the control heat sink and the vehicle frame.*

Control wire plugs and other exposed transistor control parts should be kept free of dirt and paint that might change the effective resistance between points.

CAUTION: The vehicle should not be plugged when the vehicle is jacked up and the drive wheels are in a free wheeling position. The higher motor speeds can create excessive voltages that can be harmful to the control.

Do not hipot (or megger) the control. Refer to control manufacturer before hipotting.

Use a lead-acid battery with the voltage and ampere hour rating specified for the vehicle. Follow normal battery maintenance procedures, recharging before 80 percent discharged with periodic equalizing charges.

Visual inspection of GE contactors contained in the traction and pump systems is recommended to occur during every

160 hours of vehicle operation. Inspection is recommended to verify that the contactors are not binding and that the tips are intact and free of contaminants.

GE does not recommend that any type of welding be performed on the vehicle after the installation of the control(s) in the vehicle. GE will not honor control failures during the warranty period when such failures are attributed to welding while the control is installed in the vehicle.

Section 4.2 Cable Routing and Separation

Electrical noise from cabling of various voltage levels can interfere with a microprocessor-based control system. To reduce this interference, GE recommends specific cable separation and routing practices, consistent with industry standards.

Section 4.2.1 Application Responsibility

The customer and customer's representative are responsible for the mechanical and environmental locations of cables. They are also responsible for applying the level rules and cabling practices defined in this section. To help ensure a lower cost, noise-free installation, GE recommends early planning of cable routing that complies with these level separation rules.

On new installations, sufficient space should be allowed to efficiently arrange mechanical and electrical equipment.

On vehicle retrofits, level rules should be considered during the planning stages to help ensure correct application and a more trouble-free installation.

Section 4.2.2. Signal/Powerlevel Definitions

The signal/power carrying cables are categorized into four defining levels: low, high, medium power, and high power. Within those levels, signals can be further divided into classes.

Sections 4.2.2.a through 4.2.2.d define these levels and classes, with specific examples of each. Section 4.2.3 contains recommendations for separating the levels.

4.2.2.a Low-Level Signals (Level L)

Low-level signals are designated as *level L*. These consist of:

- Analog signals 0 through ± 15 V
- Digital signals whose logic levels are less than 15 V DC
- 4 – 20 mA current loops
- DC busses less than 15 V and 250 mA

The following are specific examples of level L signals used in drive equipment cabling:

- Control common tie
- DC buses feeding sensitive analog or digital hardware
- All wiring connected to components associated with sensitive analog hardware with less than 5V signals (for example, potentiometers and tachometers)
- Digital tachometers and resolvers
- Dash display cabling
- RS-232 cabling

Note: Signal inputs to analog and digital blocks should be run as shielded twisted-pair (for example, inputs from tachometers, potentiometers, and dash displays).

4.2.2.b High-Level Signals (Level H)

High-level signals are designated as *level H*. These signals consist of:

- Analog and digital signals greater than 15 V DC and less than 250 mA

For example, switch inputs connected to battery volts are examples of level H signals used in drive equipment cabling.

4.2.2.c Medium-Power Signals (Level MP)

Medium power signals are designated as *level MP*. These signals consist of:

- DC switching signals greater than 15 V
- Signals with currents greater than 250 mA and less than 10A

The following are specific examples of level MP signals used in drive equipment cabling:

- DC busses less than 10 A
- Contactor coils less than 10 A
- Machine fields less than 10 A

4.2.2.d. High Power Signals (Level HP)

Power wiring is designated as *level HP*. This consists of DC buses and motor wiring with currents greater than 10 A. The following are specific examples of level HP signals used in drive equipment cabling:

- Motor armature loops
- DC outputs 10 A and above
- Motor field loops 10 A and above

4.2.3. Cable Spacing Guidelines

Recommended spacing (or clearance) between cables (or wires) is dependent on the level of the wiring inside them. For correct level separation when installing cable, the

customer must apply the **general guidelines** (section 4.2.3.a), outlined below.

4.2.3.a General Cable Spacing

The following general practices should be used for *all levels* of cabling:

- All cables and wires of like signal levels and power levels must be grouped together.
- In general, different levels must run in separate wire bundles, as defined in the different classes, identified above. Intermixing cannot be allowed, unless noted by exception.
- Interconnecting wire runs should carry a level designation.
- If wires are the same level and same type signal, group those wires from one location to any other location together in multiconductor cables or bind them together with twine or zip-ties.
- When unlike signals must cross, cross them in 90° angles at a maximum spacing. Where it is not possible to maintain spacing, place a grounded steel barrier between unlike levels at the crossover point.

4.2.4 Cabling for Vehicle Retrofits

Reducing electrical noise on vehicle retrofits requires careful planning. Lower and higher levels should never encircle each other or run parallel for long distances. It is practical to use existing wire runs or trays as long as the level spacing (see section 4.2.2) can be maintained for the full length of the run.

Existing cables are generally of high voltage potential and noise producing. Therefore, route levels L and H in a path separate from existing cables, whenever possible.

For level L wiring, use barriers in existing wire runs to minimize noise potential.

Do not loop level L signal wires around level H, level MP, or HP wires.

4.2.5 RF Interference

To prevent radio frequency (RF) interference, care should be taken in routing power cables in the vicinity of radio-controlled devices.

Section 4.2.6 Suppression

Unless specifically noted otherwise, suppression (for example, a snubber) is required on all inductive devices controlled by an output. This suppression minimizes noise and prevents damage caused by electrical surges.

Section 4.3 Recommended Lubrication of Pins and Sockets Prior to Installation

Beginning in January of 1999, GE implemented the addition of a lubricant to all connections using pins and sockets on EV100/EV200 and Gen II products. Any connection made by GE to the A, B, X, Y, or Z plugs, includes the lubricant NYE 760G to prevent fretting of these connections during vehicle operation.

Fretting occurs during microscopic movement at the contact points of the connection. This movement exposes the base metal of the connector pin which, when oxygen is present, allows oxidation to occur. Sufficient build up of the oxidation can cause intermittent contact and intermittent vehicle operation. This can occur at any similar type of connection, whether at the control or in any associated vehicle wiring, and the resultant intermittent contact can provide the same fault indication as actual component failure.

The addition of the NYE 760G lubricant will prevent the oxidation process by eliminating the access of oxygen to the contact point. GE recommends the addition of this lubricant to the 12 pin and 23 pin plugs of all new Gen II controls at the time of their installation into a vehicle

When servicing existing vehicles exhibiting symptoms of intermittent mis-operation or shutdown by the GE control, GE recommends the addition of this lubricant to all 12 and 23 pin plugs, after proper cleaning of the connectors, as a preventative measure to insure fretting is not an issue before GE control replacement. Also, for long term reliable control operation, the plug terminals must be maintained per these instructions with the recommended contact cleaner and lubricant which provides a high degree of environmental and fretting protection.

New and re-manufactured control plugs are cleaned and lubricated prior to shipment from the factory. However, in applications where severe vibration or high temperature cycling and excessive humidity (such as freezers) are present, it is recommended that the plug terminals be cleaned and lubricated every year, per this instructions. In normal applications, plug maintenance should be performed every two years, unless intermittent problems arise with the plugs, requiring more immediate attention.

Warning: Do not use any other cleaners or lubricants other than the ones specified.

WARNING: Before conducting maintenance on the vehicle, jack up the drive wheels, disconnect the battery and discharge the capacitors. Consult the Operation and Service Manual for your particular vehicle for details on discharging the capacitors; this procedure differs between SCR and Transistor controls.

1. **Disconnect** plug from controller or mating plug.

2. **Locate** the plug that contains the socket (female) terminals. *Maintenance needs only to be performed on the plug containing the socket (female) type terminals. Reconnecting the plugs will lubricate the pin (male) terminals.*

3. **Clean** each terminal using Chemtronics contact cleaner "Pow-R-WasH CZ " as shown in Figure 1.

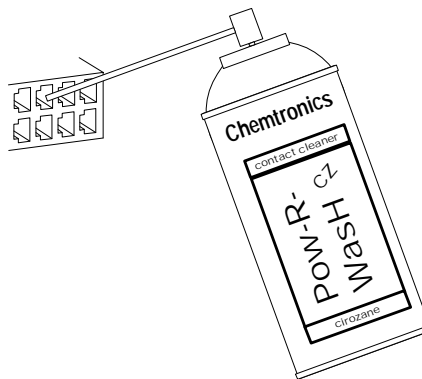

Figure 1

4. **Lubricate** each terminal using Nye 760G lubricant as shown in figure 2. Apply enough lubricant to each terminal opening to completely fill each opening to a depth of .125" minimum.

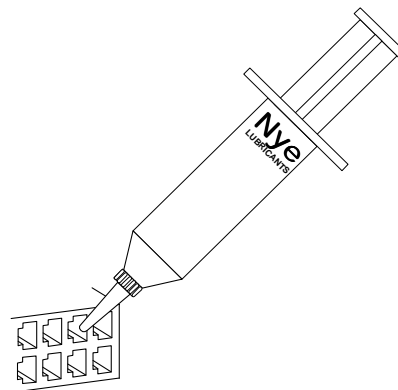

Figure 2

5. **Reconnect** plugs.

Reference

Cleaner	Chemtronics Pow-R-WasH CZ Contact Cleaner
Lubricant	Nye Lubricants NYOGEL 760G
GE Plug Lub Kit	Contains both above products: 328A1777G1

Section 4.4 General Troubleshooting Instructions

Trouble-shooting the ZX family of controls should be quick and easy when following the instructions outlined in the following status code instruction sheets.

If mis-operation of the vehicle occurs, a status code will be displayed on the Dash Display (for vehicles equipped with a Dash Display) or made available by plugging a Handset into the plug "Y" location, and then reading the status code.

With the status code number, follow the procedures outlined in the status code instruction sheets to determine the problem.

Important Note: Due to the interaction of the logic card with all vehicle functions, almost any status code or control fault could be caused by the logic card. After all other status code procedures have been followed and no problem is found, the controller should then be replaced as the last option to correct the problem.

The same device designations have been maintained on different controls but the wire numbers may vary. Refer to the elementary and wiring diagrams for your specific control. The wire numbers shown on the elementary diagram will have identical numbers on the corresponding wiring diagrams for a specific vehicle, but these numbers may be different from the numbers referenced in this publication.

WARNING: Before trouble-shooting, jack up the drive wheels, disconnect the battery and discharge the capacitors. Reconnect the battery as needed for specific checks. Capacitors should be discharged by connecting a 200 ohm 2 watt resistor between the positive and negative terminals on the control panel.

Check resistance on R x 1000 scale from frame to power and control terminals. A resistance of less than 20,000 ohms can cause misleading symptoms. Resistance less than 1000 ohms should be corrected first.

Before proceeding, visually check for loose wiring, mis-aligned linkage to the accelerator switch, signs of overheating of components, etc.

Tools and test equipment required are: clip leads, volt-ohm meter (20,000 ohms per volt) and basic hand tools.

Section 4.5 Traction Control Codes

TRACTION STATUS CODE	DESCRIPTION OF STATUS	CAUSE OF STATUS INDICATION
NONE	Segments do not illuminate on the Dash Display and/or the Handset.	No input voltage to the control card or the display unit.
MEMORY RECALL NO	CORRECTIVE ACTIONS	<u>TROUBLE-SHOOTING DIAGRAM</u>
Circuits valid for Traction Controller	<p><u>SYMPTOM</u> Display screen on Dash Display and/or Handset is blank.</p> <p><u>POSSIBLE CAUSE</u> Positive or negative control voltage is not present.</p> <ul style="list-style-type: none"> • Insure that the key switch is closed and voltage is present between P1 & battery negative (Power Terminal "NEG"). Also check for voltage between P2 and control negative. <p>Open circuit between control card Plug Y & the Dash Display or Handset.</p> <ul style="list-style-type: none"> • Check for an open circuit or loose connection going from the "Y" plug and the Dash Display or Handset. <p>Defective Dash Display or Handset.</p> <ul style="list-style-type: none"> • Replace Dash Display or Handset. 	

TRACTION STATUS CODE	DESCRIPTION OF STATUS	CAUSE OF STATUS INDICATION
-05	Start switch fails to close.	This status code will be displayed when the accelerator voltage at P7 is >1.5V, with the start switch open (P3<7.2V)
MEMORY RECALL NO	CORRECTIVE ACTIONS	<u>TROUBLE-SHOOTING DIAGRAM</u>
Circuits valid for Traction Controller	<p><u>SYMPTOM</u> Control will not operate.</p> <p><u>POSSIBLE CAUSE</u> Defective start switch circuit.</p> <ul style="list-style-type: none"> • Check start switch to insure closure when accelerator pedal is depressed. • Check for open circuit or loose connections in start switch wiring. <p>Defective accelerator switch.</p> <ul style="list-style-type: none"> • Check accelerator switch potentiometer for proper operation and ohmic value 	

TRACTION STATUS CODE	DESCRIPTION OF STATUS	CAUSE OF STATUS INDICATION
-06	The accelerator pedal is depressed with no direction selected.	This status code will be displayed when the accelerator voltage, at P7 > 1.5V, and no direction is selected (P4 and P5 are both less than 7.2V)
MEMORY RECALL NO	CORRECTIVE ACTIONS	<u>TROUBLE-SHOOTING DIAGRAM</u>
Circuits valid for Traction Controller	<p><u>SYMPTOM</u> Control will not operate.</p> <p><u>POSSIBLE CAUSE</u> Accelerator pedal is depressed before closing forward or reverse directional switch.</p> <ul style="list-style-type: none"> Status code will disappear when directional switch is closed or when accelerator pedal is released. <p>Defective directional switch</p> <ul style="list-style-type: none"> Check forward or reverse switch to insure closure when direction is selected. <p>Open circuit between directional switch(es) and 12V positive or between directional switch(es) and P4 or P5.</p> <ul style="list-style-type: none"> Check all control wires and connections shown in trouble shooting diagram. 	

TRACTION STATUS CODE	DESCRIPTION OF STATUS	CAUSE OF STATUS INDICATION
-08	Accelerator voltage input is too high on power up after initial key switch closure.	This status code will be displayed when the accelerator input voltage at P7 > 1.24V and either the battery plug or key switch is opened and closed.
MEMORY RECALL NO	CORRECTIVE ACTIONS	<u>TROUBLE-SHOOTING DIAGRAM</u>
Circuits valid for Traction Controller	<p><u>SYMPTOM</u> Control will not operate</p> <p><u>POSSIBLE CAUSE</u> Accelerator input is mis-adjusted or defective.</p> <ul style="list-style-type: none"> Input voltage at P7 should be less than 1.24 volts. Adjust or replace accelerator unit to insure that the voltage at P7 is less than 1.24 volts before depressing pedal. <p>Disconnect wire from P7. Check for short circuit from wire to P15. Resistance should be greater than 3.5K ohms.</p> <p>Open circuit at P8 or open potentiometer wiper at P7 – verify continuity of wiring at both points.</p>	

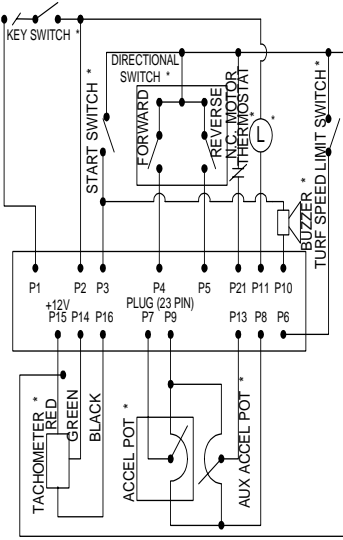
TRACTION STATUS CODE	DESCRIPTION OF STATUS	CAUSE OF STATUS INDICATION
-09	Both the forward and reverse switches are closed at the same time.	This status code will be displayed when P4 and P5 are less than 7.2 volts, and P7 is less than 2.5 volts.
MEMORY RECALL NO	CORRECTIVE ACTIONS	<u>TROUBLE-SHOOTING DIAGRAM</u>
Circuits valid for Traction Controller	<p><u>SYMPTOM</u> Control will not operate.</p> <p><u>POSSIBLE CAUSE</u> Accelerator pedal is depressed before closing forward or reverse directional switch.</p> <ul style="list-style-type: none"> Status code will disappear when directional switch is closed or when accelerator pedal is released. <p>Defective directional switch</p> <ul style="list-style-type: none"> Check forward or reverse switch to insure closure when direction is selected. <p>Open circuit between directional switch(es) and 12V positive or between directional switch(es) and P4 or P5.</p> <ul style="list-style-type: none"> Check all control wires and connections shown in Trouble Shooting Diagram. 	 <p>The diagram shows a 23-pin connector with pins P1 through P16. P1 is +12V, P15 is ground. P2, P3, P4, P5, P7, P8, P9, P10, P11, P12, P13, P14, P16 are connected to various components: KEY SWITCH, START SWITCH, DIRECTIONAL SWITCH (FORWARD/REVERSE), NTC MOTOR THERMOSTAT, BUZZER, TURF SPEED LIMIT SWITCH, TACHOMETER (RED, GREEN, BLACK), ACCEL POT, and AUX ACCEL POT.</p>

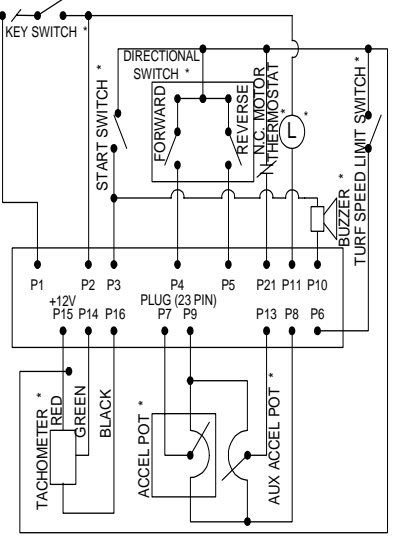
TRACTION STATUS CODE	DESCRIPTION OF STATUS	CAUSE OF STATUS INDICATION
-11	Start switch closed on power up after initial key switch closure.	This status code will be displayed when P3 is greater than 7.2V when the key switch is closed.
MEMORY RECALL NO	CORRECTIVE ACTIONS	<u>TROUBLE-SHOOTING DIAGRAM</u>
Circuits valid for Traction Controller	<p><u>SYMPTOM</u> Control will not operate.</p> <p><u>POSSIBLE CAUSE</u> Start switch is mis-adjusted or defective.</p> <ul style="list-style-type: none"> Input voltage at P3 should be less than 7.2V at key switch closure. Adjust or replace accelerator unit to insure that the voltage at P3 is less than 7.2V before closing the start switch. <p>Short circuit between P15 and P3 in start switch input circuit.</p> <ul style="list-style-type: none"> Disconnect wire from P3. Check for short circuit from this wire to 12V positive. Resistance should be greater than 4.7K ohms. <p>Defective control.</p> <ul style="list-style-type: none"> Disconnect wire from P3. Measure voltage from P3 to negative. Voltage should be zero. If not, replace the control. 	 <p>The diagram is identical to the one for status code -09, showing the 23-pin connector and its connections to the KEY SWITCH, START SWITCH, DIRECTIONAL SWITCH, NTC MOTOR THERMOSTAT, BUZZER, TURF SPEED LIMIT SWITCH, TACHOMETER, ACCEL POT, and AUX ACCEL POT.</p>

TRACTION STATUS CODE	DESCRIPTION OF STATUS	CAUSE OF STATUS INDICATION
-15	Battery voltage is too low at initial key switch closure.	This status code will be displayed when the battery volts are less than 68.3 volts at initial key switch on.
MEMORY RECALL NO	CORRECTIVE ACTIONS	<u>TROUBLE-SHOOTING DIAGRAM</u>
Circuits valid for Traction Controller	<p><u>SYMPTOM</u> Control will not operate.</p> <p><u>POSSIBLE CAUSE</u> Discharged battery</p> <ul style="list-style-type: none"> • Check battery voltage to confirm that it is a minimum of 68.3 volts. Charge battery, if required. <p>Defective battery</p> <ul style="list-style-type: none"> • Check each battery cell for proper voltage (greater than 1.95 volts at cell). Replace or repair battery. <p>Incorrect control card adjustment.</p> <ul style="list-style-type: none"> • Check Function 15 for proper adjustment for battery being used. See Handset instruction sheet for details. Adjust to proper settings. <p>Check "minimum" battery volts at P1 & NEG.</p>	

TRACTION STATUS CODE	DESCRIPTION OF STATUS	CAUSE OF STATUS INDICATION
-16	Battery voltage is too high at initial key switch closure.	This status code will be displayed when the battery volts are greater than 86 volts at initial key switch on.
MEMORY RECALL NO	CORRECTIVE ACTIONS	<u>TROUBLE-SHOOTING DIAGRAM</u>
Circuits valid for Traction Controller	<p><u>SYMPTOM</u> Control will not operate.</p> <p><u>POSSIBLE CAUSE</u> Discharged battery</p> <ul style="list-style-type: none"> • Check battery voltage to confirm that it is a minimum of 68.3 volts. Charge battery, if required. <p>Battery overcharged or incorrect battery used.</p> <ul style="list-style-type: none"> • Check each battery cell for proper voltage (maximum 2.4 volts per cell). If voltage is excessive, check battery charger for proper output voltage. <p>Incorrect control card adjustment.</p> <ul style="list-style-type: none"> • Check Function 15 for proper adjustment for battery being used. See Handset instruction sheet for details. Adjust to proper settings. <p>Check "maximum" battery volts at P1 & NEG.</p>	

TRACTION STATUS CODE	DESCRIPTION OF STATUS	CAUSE OF STATUS INDICATION
-21	Accelerator voltage is too high.	This status code will be displayed when the accelerator voltage at P7 is greater than 4.5 volts.
MEMORY RECALL NO	CORRECTIVE ACTIONS	<u>TROUBLE-SHOOTING DIAGRAM</u>
Circuits valid for Traction Controller	<p><u>SYMPTOM</u> Control will not operate.</p> <p><u>POSSIBLE CAUSE</u> Accelerator input is mis-adjusted or defective.</p> <ul style="list-style-type: none"> Input voltage at P7 should be less than 4.5 volts after initial key switch closure. Open wire exists between potentiometer negative and P8. Open wire exists between P7 and potentiometer negative. 	<p>The diagram shows a 23-pin connector with pins P1 through P16. P1 is +12V, P2 is GREEN, P3 is BLACK, P4 is TACHOMETER (RED, GREEN, BLACK), P5 is ACCEL POT, P6 is AUX ACCEL POT, P7 is PLUG (23 PIN), P8 is THERMOSTAT, P9 is BOZZER, P10 is TURF SPEED LIMIT SWITCH, P11 is L, P12 is REVERSE, P13 is FORWARD, P14 is START SWITCH, P15 is DIRECTIONAL SWITCH, and P16 is KEY SWITCH. The diagram illustrates the wiring for these components, including a tachometer, directional switch, start switch, and two accelerators (ACCEL POT and AUX ACCEL POT).</p>

TRACTION STATUS CODE	DESCRIPTION OF STATUS	CAUSE OF STATUS INDICATION
-23	Motor field current is too high when the start switch is closed and the reverse direction is selected.	This status code will be displayed when the current draw in the motor field is too high on start up in the reverse direction.
MEMORY RECALL NO	CORRECTIVE ACTIONS	<u>TROUBLE-SHOOTING DIAGRAM</u>
Circuits valid for Traction Controller	<p><u>SYMPTOM</u> Control will not operate.</p> <p><u>POSSIBLE CAUSE</u> Defective control.</p> <ul style="list-style-type: none"> Replace controller unit. 	<p>NO GRAPHIC FOR THIS STATUS CODE</p>

TRACTION STATUS CODE	DESCRIPTION OF STATUS	CAUSE OF STATUS INDICATION
-24	Motor field current is too high on when the start switch is closed and the forward direction is selected.	This status code will be displayed when the current draw in the motor field is too high on start up in the forward direction.
MEMORY RECALL NO	CORRECTIVE ACTIONS	<u>TROUBLE-SHOOTING DIAGRAM</u>
Circuits valid for Traction Controller	<p><u>SYMPTOM</u> Control will not operate.</p> <p><u>POSSIBLE CAUSE</u> Defective control.</p> <ul style="list-style-type: none"> • Replace controller unit. 	<p>NO GRAPHIC FOR THIS STATUS CODE</p>

TRACTION STATUS CODE	DESCRIPTION OF STATUS	CAUSE OF STATUS INDICATION
-27	12V buss is too low.	This status code will be displayed when the voltage at P1 is less than 9.35V.
MEMORY RECALL YES	CORRECTIVE ACTIONS	<u>TROUBLE-SHOOTING DIAGRAM</u>
Circuits valid for Traction Controller	<p><u>SYMPTOM</u> Line contactor opens and closes and then can only be closed by opening and closing the key switch.</p> <p><u>POSSIBLE CAUSE</u> Discharged battery.</p> <ul style="list-style-type: none"> • Check battery to insure proper state of charge. Voltage may be dropping below 12V under load. <p>Loose connection at P1.</p> <ul style="list-style-type: none"> • Insure that the wire connection at P1 is tight. <p>Defective control.</p> <ul style="list-style-type: none"> • Replace controller unit. 	<p>The diagram shows a 12V battery with positive (+) and negative (-) terminals. A fuse labeled 'FU3' is connected to the positive terminal. The circuit continues through a 'CHARGER SWITCH' and a 'KEY SWITCH' in series. The output of the key switch is connected to terminal 'P1'. Terminal 'P2' is also shown but is not connected to any other component in this diagram. A 'NEG' terminal is also shown, connected to the negative terminal of the battery.</p>

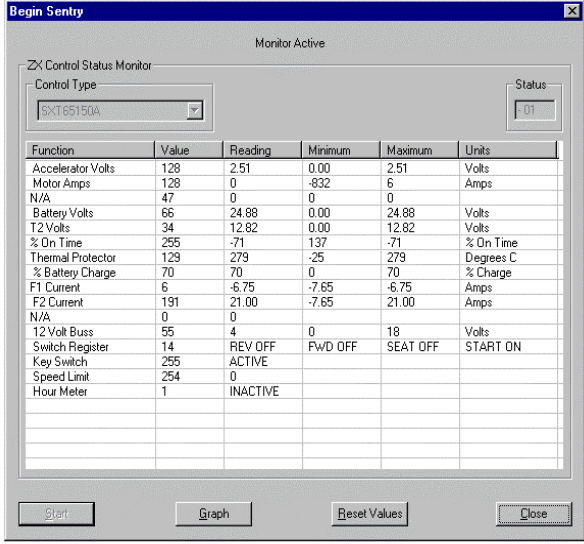
TRACTION STATUS CODE	DESCRIPTION OF STATUS	CAUSE OF STATUS INDICATION																																																																																																						
-41	Open thermal protector (TP) or transistor over temperature.	This status code will be displayed when the voltage at the thermal protector is too high.																																																																																																						
MEMORY RECALL YES	CORRECTIVE ACTIONS	TROUBLE-SHOOTING DIAGRAM																																																																																																						
Circuits valid for Traction Controller	<p>SYMPTOM Reduced or no power to traction motor in control range.</p> <p>POSSIBLE CAUSE Control is in thermal cut back.</p> <ul style="list-style-type: none"> Allow control to cool, status code should disappear. <p>Defective control.</p> <ul style="list-style-type: none"> Replace controller unit. (Values of greater than 4 V at the thermal protector are typically indicative of a failed control.) <p><i>GE Sentry for Windows</i> software can be used to monitor control operation, and it will display a value for the thermal protector that is greater than 84 (corresponding to 1.65V), triggering this status code.</p>	 <table border="1"> <thead> <tr> <th>Function</th> <th>Value</th> <th>Reading</th> <th>Minimum</th> <th>Maximum</th> <th>Units</th> </tr> </thead> <tbody> <tr><td>Accelerator Volts</td><td>128</td><td>2.51</td><td>0.00</td><td>2.51</td><td>Volts</td></tr> <tr><td>Motor Amps</td><td>128</td><td>0</td><td>-832</td><td>6</td><td>Amps</td></tr> <tr><td>N/A</td><td>47</td><td>0</td><td>0</td><td>0</td><td></td></tr> <tr><td>Battery Volts</td><td>66</td><td>24.88</td><td>0.00</td><td>24.88</td><td>Volts</td></tr> <tr><td>T2 Volts</td><td>34</td><td>12.82</td><td>0.00</td><td>12.82</td><td>Volts</td></tr> <tr><td>% On Time</td><td>255</td><td>-71</td><td>137</td><td>-71</td><td>% On Time</td></tr> <tr><td>Thermal Protector</td><td>129</td><td>279</td><td>-25</td><td>279</td><td>Degrees C</td></tr> <tr><td>% Battery Charge</td><td>70</td><td>70</td><td>0</td><td>70</td><td>% Charge</td></tr> <tr><td>F1 Current</td><td>6</td><td>-6.75</td><td>-7.65</td><td>-6.75</td><td>Amps</td></tr> <tr><td>F2 Current</td><td>191</td><td>21.00</td><td>-7.65</td><td>21.00</td><td>Amps</td></tr> <tr><td>N/A</td><td>0</td><td>0</td><td></td><td></td><td></td></tr> <tr><td>12 Volt Buss</td><td>55</td><td>4</td><td>0</td><td>18</td><td>Volts</td></tr> <tr><td>Switch Register</td><td>14</td><td>REV OFF</td><td>FwD OFF</td><td>SEAT OFF</td><td>START ON</td></tr> <tr><td>Key Switch</td><td>255</td><td>ACTIVE</td><td></td><td></td><td></td></tr> <tr><td>Speed Limit</td><td>254</td><td>0</td><td></td><td></td><td></td></tr> <tr><td>Hour Meter</td><td>1</td><td>INACTIVE</td><td></td><td></td><td></td></tr> </tbody> </table>	Function	Value	Reading	Minimum	Maximum	Units	Accelerator Volts	128	2.51	0.00	2.51	Volts	Motor Amps	128	0	-832	6	Amps	N/A	47	0	0	0		Battery Volts	66	24.88	0.00	24.88	Volts	T2 Volts	34	12.82	0.00	12.82	Volts	% On Time	255	-71	137	-71	% On Time	Thermal Protector	129	279	-25	279	Degrees C	% Battery Charge	70	70	0	70	% Charge	F1 Current	6	-6.75	-7.65	-6.75	Amps	F2 Current	191	21.00	-7.65	21.00	Amps	N/A	0	0				12 Volt Buss	55	4	0	18	Volts	Switch Register	14	REV OFF	FwD OFF	SEAT OFF	START ON	Key Switch	255	ACTIVE				Speed Limit	254	0				Hour Meter	1	INACTIVE			
Function	Value	Reading	Minimum	Maximum	Units																																																																																																			
Accelerator Volts	128	2.51	0.00	2.51	Volts																																																																																																			
Motor Amps	128	0	-832	6	Amps																																																																																																			
N/A	47	0	0	0																																																																																																				
Battery Volts	66	24.88	0.00	24.88	Volts																																																																																																			
T2 Volts	34	12.82	0.00	12.82	Volts																																																																																																			
% On Time	255	-71	137	-71	% On Time																																																																																																			
Thermal Protector	129	279	-25	279	Degrees C																																																																																																			
% Battery Charge	70	70	0	70	% Charge																																																																																																			
F1 Current	6	-6.75	-7.65	-6.75	Amps																																																																																																			
F2 Current	191	21.00	-7.65	21.00	Amps																																																																																																			
N/A	0	0																																																																																																						
12 Volt Buss	55	4	0	18	Volts																																																																																																			
Switch Register	14	REV OFF	FwD OFF	SEAT OFF	START ON																																																																																																			
Key Switch	255	ACTIVE																																																																																																						
Speed Limit	254	0																																																																																																						
Hour Meter	1	INACTIVE																																																																																																						

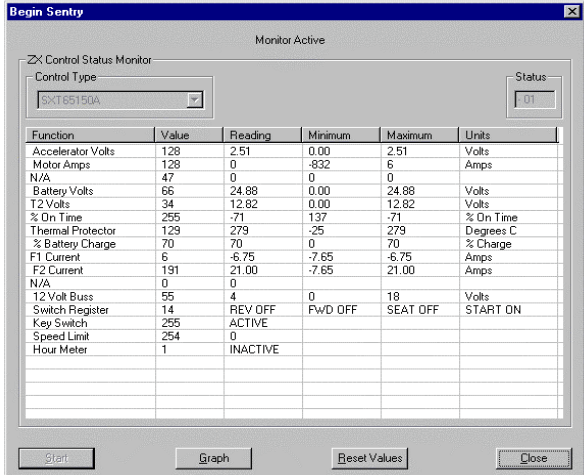
TRACTION STATUS CODE	DESCRIPTION OF STATUS	CAUSE OF STATUS INDICATION																																																																																																						
-42	Motor armature offset voltage is too high.	This status code will be displayed when the value of motor amps is greater than 138 (corresponding to 2.7 volts) with no current flowing in the motor circuit.																																																																																																						
MEMORY RECALL NO	CORRECTIVE ACTIONS	TROUBLE-SHOOTING DIAGRAM																																																																																																						
Circuits valid for Traction Controller	<p>SYMPTOM Control will not operate.</p> <p>POSSIBLE CAUSE Defective control.</p> <ul style="list-style-type: none"> Replace controller unit. <p><i>GE Sentry for Windows</i> software can be used to monitor control operation, and it will display a value for the motor amps that is greater than 138, (corresponding to 2.7V), triggering this status code.</p>	 <table border="1"> <thead> <tr> <th>Function</th> <th>Value</th> <th>Reading</th> <th>Minimum</th> <th>Maximum</th> <th>Units</th> </tr> </thead> <tbody> <tr><td>Accelerator Volts</td><td>128</td><td>2.51</td><td>0.00</td><td>2.51</td><td>Volts</td></tr> <tr><td>Motor Amps</td><td>128</td><td>0</td><td>-832</td><td>6</td><td>Amps</td></tr> <tr><td>N/A</td><td>47</td><td>0</td><td>0</td><td>0</td><td></td></tr> <tr><td>Battery Volts</td><td>66</td><td>24.88</td><td>0.00</td><td>24.88</td><td>Volts</td></tr> <tr><td>T2 Volts</td><td>34</td><td>12.82</td><td>0.00</td><td>12.82</td><td>Volts</td></tr> <tr><td>% On Time</td><td>255</td><td>-71</td><td>137</td><td>-71</td><td>% On Time</td></tr> <tr><td>Thermal Protector</td><td>129</td><td>279</td><td>-25</td><td>279</td><td>Degrees C</td></tr> <tr><td>% Battery Charge</td><td>70</td><td>70</td><td>0</td><td>70</td><td>% Charge</td></tr> <tr><td>F1 Current</td><td>6</td><td>-6.75</td><td>-7.65</td><td>-6.75</td><td>Amps</td></tr> <tr><td>F2 Current</td><td>191</td><td>21.00</td><td>-7.65</td><td>21.00</td><td>Amps</td></tr> <tr><td>N/A</td><td>0</td><td>0</td><td></td><td></td><td></td></tr> <tr><td>12 Volt Buss</td><td>55</td><td>4</td><td>0</td><td>18</td><td>Volts</td></tr> <tr><td>Switch Register</td><td>14</td><td>REV OFF</td><td>FwD OFF</td><td>SEAT OFF</td><td>START ON</td></tr> <tr><td>Key Switch</td><td>255</td><td>ACTIVE</td><td></td><td></td><td></td></tr> <tr><td>Speed Limit</td><td>254</td><td>0</td><td></td><td></td><td></td></tr> <tr><td>Hour Meter</td><td>1</td><td>INACTIVE</td><td></td><td></td><td></td></tr> </tbody> </table>	Function	Value	Reading	Minimum	Maximum	Units	Accelerator Volts	128	2.51	0.00	2.51	Volts	Motor Amps	128	0	-832	6	Amps	N/A	47	0	0	0		Battery Volts	66	24.88	0.00	24.88	Volts	T2 Volts	34	12.82	0.00	12.82	Volts	% On Time	255	-71	137	-71	% On Time	Thermal Protector	129	279	-25	279	Degrees C	% Battery Charge	70	70	0	70	% Charge	F1 Current	6	-6.75	-7.65	-6.75	Amps	F2 Current	191	21.00	-7.65	21.00	Amps	N/A	0	0				12 Volt Buss	55	4	0	18	Volts	Switch Register	14	REV OFF	FwD OFF	SEAT OFF	START ON	Key Switch	255	ACTIVE				Speed Limit	254	0				Hour Meter	1	INACTIVE			
Function	Value	Reading	Minimum	Maximum	Units																																																																																																			
Accelerator Volts	128	2.51	0.00	2.51	Volts																																																																																																			
Motor Amps	128	0	-832	6	Amps																																																																																																			
N/A	47	0	0	0																																																																																																				
Battery Volts	66	24.88	0.00	24.88	Volts																																																																																																			
T2 Volts	34	12.82	0.00	12.82	Volts																																																																																																			
% On Time	255	-71	137	-71	% On Time																																																																																																			
Thermal Protector	129	279	-25	279	Degrees C																																																																																																			
% Battery Charge	70	70	0	70	% Charge																																																																																																			
F1 Current	6	-6.75	-7.65	-6.75	Amps																																																																																																			
F2 Current	191	21.00	-7.65	21.00	Amps																																																																																																			
N/A	0	0																																																																																																						
12 Volt Buss	55	4	0	18	Volts																																																																																																			
Switch Register	14	REV OFF	FwD OFF	SEAT OFF	START ON																																																																																																			
Key Switch	255	ACTIVE																																																																																																						
Speed Limit	254	0																																																																																																						
Hour Meter	1	INACTIVE																																																																																																						

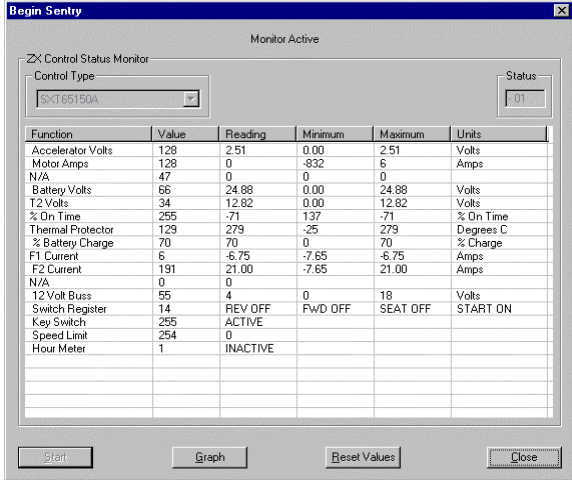
TRACTION STATUS CODE	DESCRIPTION OF STATUS	CAUSE OF STATUS INDICATION
-43	Motor armature offset voltage is too low.	This status code will be displayed when the value of motor amps is less than 117 (corresponding to 2.3 volts) with no current flowing in the motor circuit.
MEMORY RECALL NO	CORRECTIVE ACTIONS	TROUBLE-SHOOTING DIAGRAM
Circuits valid for Traction Controller	<p>SYMPTOM Control will not operate.</p> <p>POSSIBLE CAUSE Defective control.</p> <ul style="list-style-type: none"> Replace controller unit. <p><i>GE Sentry for Windows</i> software can be used to monitor control operation, and it will display a value for the motor amps that is less than 117 (corresponding to 2.3V), triggering this status code.</p>	

TRACTION STATUS CODE	DESCRIPTION OF STATUS	CAUSE OF STATUS INDICATION
-44	Armature transistor did not turn off properly.	This status code will be displayed when, during control operation, the armature transistor fails to turn off. This will result in a PMT condition
MEMORY RECALL YES	CORRECTIVE ACTIONS	TROUBLE-SHOOTING DIAGRAM
Circuits valid for Traction Controller	<p>SYMPTOM Line contactor opens and closes, then can only be closed by opening and closing the key switch.</p> <p>POSSIBLE CAUSE Defective control.</p> <ul style="list-style-type: none"> Replace controller unit. 	<p>NO GRAPHIC FOR THIS STATUS CODE</p>

TRACTION STATUS CODE	DESCRIPTION OF STATUS	CAUSE OF STATUS INDICATION
-45	Armature transistor did not turn on properly.	This status code will be displayed when, during control operation, the armature transistor fails to turn on properly. This will result in a PMT condition
MEMORY RECALL YES	CORRECTIVE ACTIONS	<u>TROUBLE-SHOOTING DIAGRAM</u>
Circuits valid for Traction Controller	<p><u>SYMPTOM</u> Line contactor opens and closes, then can only be closed by opening and closing the key switch.</p> <p><u>POSSIBLE CAUSE</u> Defective control.</p> <ul style="list-style-type: none"> Replace controller unit. 	NO GRAPHIC FOR THIS STATUS CODE

TRACTION STATUS CODE	DESCRIPTION OF STATUS	CAUSE OF STATUS INDICATION
-46	"Look Ahead" test for A2 volts is less than 12.5% of battery volts.	This status code will be displayed when the voltage at A2 is less than 12.5% of battery volts and I_m is greater than 52 amps, when the control is in the neutral state, with no start switch or direction selected.
MEMORY RECALL YES	CORRECTIVE ACTIONS	<u>TROUBLE-SHOOTING DIAGRAM</u>
Circuits valid for Traction Controller	<p><u>SYMPTOM</u> Line contactor will not pickup.</p> <p><u>POSSIBLE CAUSE</u> Check for short circuit from the motor armature to the frame of the vehicle.</p> <p>Defective control.</p> <ul style="list-style-type: none"> Replace controller unit. 	<p>The diagram shows a battery (BATT) connected to a control unit. The positive terminal of the battery goes through fuse FU3 (10A) to the POS terminal of the control unit. The negative terminal goes through fuse FU1 (400A) to the NEG terminal. The control unit has terminals A1 and A2 for the motor. The motor has terminals F1 and F2 for the field winding and A1 and A2 for the armature. The field winding is connected between F1 and F2. The armature is connected between A1 and A2.</p>

TRACTION STATUS CODE	DESCRIPTION OF STATUS	CAUSE OF STATUS INDICATION
-49	Motor field current is too low during the run mode.	This status code will be displayed when the current draw in the motor field is less than 1.3 amps and armature current is greater than 100 amps for more than 1.27 seconds during the run mode.
MEMORY RECALL YES	CORRECTIVE ACTIONS	<u>TROUBLE-SHOOTING DIAGRAM</u>
Circuits valid for Traction Controller	<p><u>SYMPTOM</u> Control will not operate.</p> <p><u>POSSIBLE CAUSE</u> Defective control.</p> <ul style="list-style-type: none"> • Replace controller unit. 	<p>NO GRAPHIC FOR THIS STATUS CODE</p>

TRACTION STATUS CODE	DESCRIPTION OF STATUS	CAUSE OF STATUS INDICATION
-51	Capacitor volts are low before the line contactor closes.	This status code will be displayed during "key on" when the capacitor volts is less than 85% of battery volts at initial key switch on.
MEMORY RECALL NO	CORRECTIVE ACTIONS	<u>TROUBLE-SHOOTING DIAGRAM</u>
Circuits valid for Traction Controller	<p><u>SYMPTOM</u> Line contactor does not close when capacitor does not pre-charge.</p> <p><u>POSSIBLE CAUSE</u> Defective control fuse.</p> <ul style="list-style-type: none"> • Check control fuse for open circuit condition. Replace fuse, if necessary. <p>Defective control.</p> <ul style="list-style-type: none"> • Replace controller unit. 	<p>The diagram illustrates the power supply circuit for the traction controller. It starts with a battery (BATT) connected to a 400A fuse (FU1) and a 10A fuse (FU3). The circuit then passes through a line contactor (LINE) to a control unit. The control unit has terminals POS, NEG, A1, and A2. The POS terminal is connected to the A1 terminal of the motor field winding. The NEG terminal is connected to the A2 terminal of the motor field winding. The motor field winding is connected to the A1 and A2 terminals of the motor armature.</p>

TRACTION STATUS CODE	DESCRIPTION OF STATUS	CAUSE OF STATUS INDICATION
-57	Controller "motor current sensor" input is too low during running.	This status code will be displayed when the voltage input from the current sensor is too low (less than 1.43V, -350 amps) during running.
MEMORY RECALL YES	CORRECTIVE ACTIONS	<u>TROUBLE-SHOOTING DIAGRAM</u>
Circuits valid for Traction Controller	<p><u>SYMPTOM</u> Control will not operate.</p> <p><u>POSSIBLE CAUSE</u> Defective control.</p> <ul style="list-style-type: none"> • Replace controller unit. <p>Line contactor tips bounce or are not fully picked up.</p>	<p>NO GRAPHIC FOR THIS STATUS CODE</p>

TRACTION STATUS CODE	DESCRIPTION OF STATUS	CAUSE OF STATUS INDICATION
-66	The field current exceeds the current limit of the field transistor.	This status code will be displayed when the field transistor exceeds its current limit. The line contactor will drop out and the key switch will have to be recycled to restart the control.
MEMORY RECALL YES	CORRECTIVE ACTIONS	<u>TROUBLE-SHOOTING DIAGRAM</u>
Circuits valid for Traction Controller	<p><u>SYMPTOM</u> Control will not operate or is sluggish on start up. Line contactor opens.</p> <p><u>POSSIBLE CAUSES</u></p> <ul style="list-style-type: none"> • Shorted field F1 to F2 • F1 or F2 terminals shorted to battery positive (B+) or to battery negative (B-) • Binding line contactor • Visually inspect tips, clean them with a solvent. • Noise • Confirm that all inductive loads/accessories are suppressed. • Excessive motor and control heating (control is in thermal cutback) 	

TRACTION STATUS CODE	DESCRIPTION OF STATUS	CAUSE OF STATUS INDICATION
-76	Capacitor (1C) voltage too high during regenerative braking.	This status code will be displayed when the voltage at 1C exceeds 96 volts during the regenerative braking cycle.
MEMORY RECALL YES	CORRECTIVE ACTIONS	<u>TROUBLE-SHOOTING DIAGRAM</u>
Circuits valid for Traction Controller	<p><u>SYMPTOM</u> Line contactor opens and closes, then opens and can only close by opening and closing the key switch.</p> <p><u>POSSIBLE CAUSE</u> Defective control.</p> <ul style="list-style-type: none"> Replace controller unit. 	

TRACTION STATUS CODE	DESCRIPTION OF STATUS	CAUSE OF STATUS INDICATION
-77	Capacitor (1C) voltage too high during motoring.	This status code will be displayed when the voltage at 1C exceeds 96 volts during motoring.
MEMORY RECALL YES	CORRECTIVE ACTIONS	<u>TROUBLE-SHOOTING DIAGRAM</u>
Circuits valid for Traction Controller	<p><u>SYMPTOM</u> Line contactor opens and closes, then opens and can only close by opening and closing the key switch.</p> <p><u>POSSIBLE CAUSE</u> Defective control.</p> <ul style="list-style-type: none"> Replace controller unit. 	

TRACTION STATUS CODE	DESCRIPTION OF STATUS	CAUSE OF STATUS INDICATION
-90	Motor thermostat is open during control operation.	This status code will be displayed when the voltage at P21 < 5.66V for at least 30 seconds.
MEMORY RECALL YES	CORRECTIVE ACTIONS	<u>TROUBLE-SHOOTING DIAGRAM</u>
Circuits valid for Traction Controller	<p><u>SYMPTOM</u> Maximum motor armature current will be limited to 100 amps, and vehicle performance will be sluggish.</p> <p><u>POSSIBLE CAUSE</u> Thermostat wire has been lost.</p> <ul style="list-style-type: none"> Verify thermostat connections inside motor. <p>Verify connection at P21.</p>	

Section 5. SX FAMILY GE HANDSET INSTRUCTIONS

Section 5.1 General Features

The GE Handset is a multi-functional tool to be used with the LX, ZX, and SX Series GE solid-state controls. The Handset consists of a Light Emitting Diode (LED) display and a keyboard for data entry. *Note: A different handset cord is required for use with SX controls than that used with LX and ZX controls.*

Section 5.2 Purpose / Setup Functions

The purpose of the Handset is to allow authorized personnel to perform the following functions of the SX family of Controls:

- Monitor existing system fault codes
- Monitor intermittent random fault codes
- Monitor battery state of charge on systems with BDI
- Monitor hourmeter reading
- Monitor or adjust the following control functions:
 - Creep speed
 - Armature Controlled Acceleration and 1A Time
 - Regenerative Braking Current Limit and Disable
 - Armature and Field Current Limit
 - Plugging Distance (Current)
 - Pedal Position Plug Range or Disable
 - 1A Drop Out Current or Disable
 - Speed Limit Points
 - Truck Management Fault Speed Limit
 - Internal Resistance Compensation for Battery State of Charge Indication
 - Battery Voltage (36/48 volts is auto ranging)
 - Selection of Card Operation Type.

Warning: Before connecting or disconnecting the Handset tool, turn off the key switch, unplug the battery and jack up the drive wheels of the vehicle.

At the transistor control traction card, unplug the "Y plug" if the dash display is in use, and plug in the Handset to the plug location "Y" on the control card. After installing the Handset tool, plug the battery in and turn the key switch on. The chart at the right details the start-up display sequence that will occur.

Note: The dash display must be disconnected when the Handset is plugged in, or the control power supply will be overloaded.

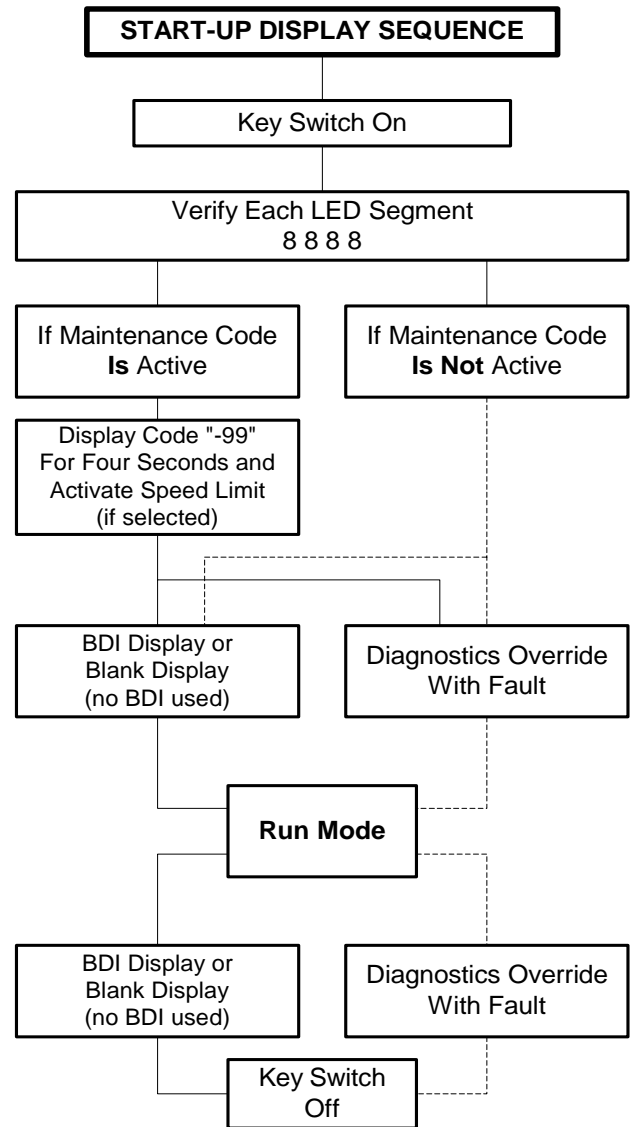

Warning: Before making any adjustments to the control, you must consult the operating and maintenance instructions supplied by the vehicle manufacturer. Failure to follow proper set up instructions could result in mis-operation or damage to the control system.

Section 5.3 Setup Function Procedures

With the Handset connected, hold down the **CONT** key and turn on the key switch. This will place you in the setup mode, ready to monitor or adjust control function settings.

NOTE: The term "Push" means to depress key for approximately one second.

Section 5.3.1 Setup Mode

SET-UP MODE		
ACTION	DISPLAY SHOWS	REMARKS
Hold Down CONT And Turn On Key	8 8 8 8	Segment Check Displayed
Push Function Number	U 0 0 5	Selected Function No. Is Displayed
After One Second Time Delay	0 8 5	Stored Value For The Function Is Displayed
Push CONT	0 8 5	Display Value Will Blink
Change Value with Adjustment Knob	1 2 5	Value Changes While Blinking
Push STORE	1 2 5	New Value Stored And Blinking Stops
Push ESC	8 8 8 8	Segment Check Displayed

At this point, another function can be monitored/changed by pushing another function number, or the vehicle can be placed in the run mode by holding the **ESC** key down for one second or longer. The display will return to either the diagnostics mode, the BDI display, or a blank display (if BDI is not used and there are no fault codes). The vehicle can now be operated with the Handset connected or the Handset can be disconnected before operation.

NOTE: You can return to the segment check mode at any time, by holding down the **ESC** key until 8888 appears in the display.

Section 5.3.2 Status Code Scrolling

The SX family of controllers furnishes a function register that contains the last 16 "stored status codes" that shut down vehicle operation (a PMT type fault that is reset by cycling the key switch) and the battery state of charge

reading at the time the fault occurred. The first of the 16 status codes will be overwritten each time a new status code occurs. This stored status code register can be cleared from memory by using the Handset.

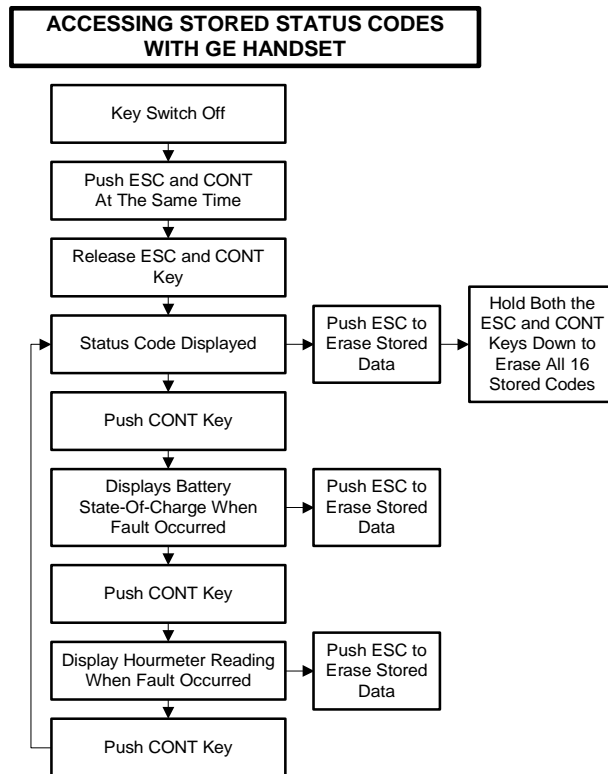

Section 5.3.3 SX Family Handset, Plug Connections and Outline Drawing

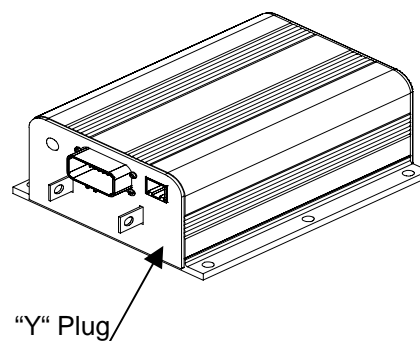

Handset Cable Part Number - 325B1002G1 (12 pin plug)
Handset Part Number - IC3645LXHS1EC2 (12 pin plug)
(includes handset, cable and case)

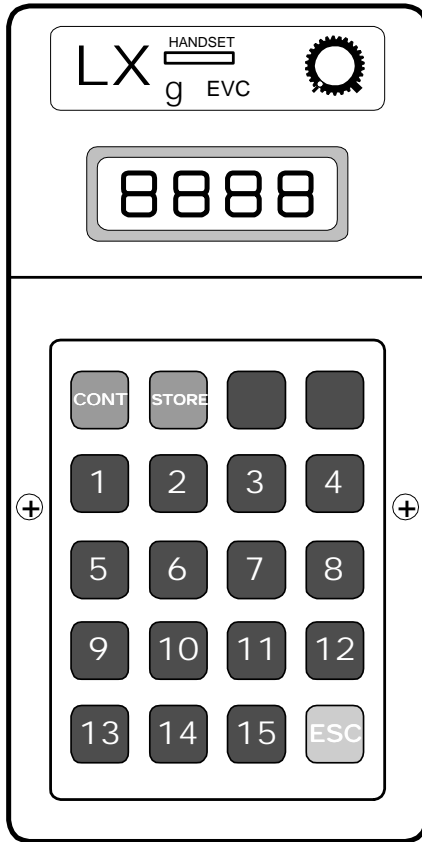

Section 5.4 Setup Functions for Traction Controller

FUNCTION 1 MPH SCALING (Push 1)

This function allows for the pulses from the tachometer to be scaled to miles per hour, based on the number of pulses received by the control in a given time. For example, if you were scaling to 8 MPH, it would correspond to the length of time that it took to capture 8 tachometer pulses when the vehicle is traveling at 8 MPH.

Range 0 to 1.28 seconds
Set 0 to 255
Resolution 0.005 seconds per set unit
Example Setting of 18 = 0.09 seconds

FUNCTION 2 CREEP SPEED (Push 2)

This function allows for the adjustment of the creep speed of the vehicle when the accelerator potentiometer is at its minimum value and the start switch is closed.

Range 2% to 15% on time
Set 0 to 255
Resolution 0.047% per set unit
Example Setting of 205 = $(205 \times 0.047) + 2$
= 11% on time

Important Note: The function is used to optimize motor and control performance and this setting will be determined by GE and OEM engineers at the time of vehicle development. This setting must not be changed by field personnel without the permission of the OEM.

FUNCTION 3 ARMATURE ACCELERATION RATE FORWARD (Push 3)

This function allows for the adjustment of the rate of time it takes for the control to accelerate to 100% applied battery voltage to the motor on hard acceleration in the forward direction.

Range 0.1 to 25.5 seconds
Set 1 to 255
Resolution 0.086 seconds per set unit
Example: Setting of 20 = $20 \times 0.086 = 1.72$ seconds

FUNCTION 4 MAX ARMATURE CURRENT LIMIT (Push 4)

This function allows for the adjustment of the armature current limit of the control during motoring.

Range 150 to 357 amps
Set 0 to 255
Resolution 0.8125 amps per unit
Example: Setting of 255 = $(255 \times 0.8125) + 150$
= 357 amps

FUNCTION 5 RESPONSE TIME OF BATTERY STATE OF CHARGE UPDATES (Push 5)

This function allows for the adjustment of the response time of the battery state of charge updates. A larger setting corresponds to a longer response time per each decrement of the battery state of charge indication.

Range 2 to 66 seconds
Set 8 to 255
Calculation $((\text{Setting}/8) + 1) \times 2 = \text{seconds}$
Example Setting of 16 = $((16/8) + 1) \times 2 = 6$ seconds

**FUNCTION 6 ARMATURE ACCELERATION RATE
 REVERSE
 (Push 6)**

This function allows for the adjustment of the rate of time it takes for the control to accelerate to 100% applied battery voltage to the motor on hard acceleration in the reverse direction.

Range	0.1 to 25.5 seconds
Set	1 to 255
Resolution	0.086 seconds per set unit
Example:	Setting of 29 = $29 \times 0.086 = 2.5$ seconds

**FUNCTION 7 MIN. FIELD CURRENT
 (Push 7)**

This function allows the adjustment of the field weakening level in order to set the top speed of the motor.

Range	0 to 37 amps
Set	51 to 255
Resolution	0.185 amps per set unit
Example	Setting of 82 = $(82-51) \times 0.185 = 5.7$ amps

CAUTION: Do not set this function to a value less than 51.

Important Note: The function is used to optimize motor and control performance and this setting will be determined by GE and OEM engineers at the time of vehicle development. This setting must not be changed by field personnel without the permission of the OEM.

**FUNCTION 8 MAX FIELD CURRENT
 (Push 8)**

This function allows for the adjustment of the maximum field current in order to obtain the maximum torque of the motor.

Range	0 to 37 amps
Set	51 to 255
Resolution	0.185 amps per set unit
Example	Setting of 251 = $(251-51) \times 0.185 = 37$ amps

CAUTION: Do not set this function to a value less than 51.

Important Note: The function is used to optimize motor and control performance and this setting will be determined by GE and OEM engineers at the time of vehicle development. This setting must not be changed by field personnel without the permission of the OEM.

**FUNCTION 9 REGEN ARMATURE CURRENT LIMIT
 (Push 9)**

This function allows for the adjustment of the maximum armature current limit during regenerative braking.

Range	32 to 240 amps
Set	1 to 255
Resolution	0.8157 amps per set unit
Example	Setting of 221 = $(221 \times 0.8157) + 32 = 212$ amps

**FUNCTION 10 PLUG/REGEN FIELD CURRENT LIMIT
 (Push 10)**

This function allows for the adjustment of the maximum field current limit during regenerative braking.

Range	0 to 37 amps
Set	51 to 255
Resolution	0.185 amps per set unit
Example	Setting of 180 = $(180-51) \times 0.185 = 24$ amps

CAUTION: Do not set this function to a value less than 51.

Important Note: The function is used to optimize motor and control performance and this setting will be determined by GE and OEM engineers at the time of vehicle development. This setting must not be changed by field personnel without the permission of the OEM.

**FUNCTION 11 TURF SPEED LIMIT
 (Push 11)**

This function allows for the adjustment of the top speed of the vehicle (maximum battery volts to the motor) when it is in Turf Mode.

Range	100% to 0% (or creep speed)
Set	51 to 170
Resolution	0.78% per set unit
Example:	Setting of 0 = no speed limit Setting of 170 = maximum speed reduction Setting of 122 = $100\% - ((122-51) - (\text{creep val}/8)) \times 0.78$

FUNCTION 12 REVERSE SPEED LIMIT
(Push 12)

This function allows for the adjustment of the top speed of the vehicle (maximum battery volts to the motor) when it is being operated in the reverse direction.

- Range 100% to 0% of battery volts
- Set 51 to 170
- Resolution 0.78% per set unit
- Example: Setting of 0 = no speed limit
- Setting of 170 = maximum speed reduction
- Setting of 149 = $100\% - ((149 - 51) - (\text{creep val}/8)) \times 0.78$

FUNCTION 13 PERCENT CHARGE SWITCH PLUG TO REGEN
(Push 13)

This function adjusts the percentage of battery volts at which the control switches from regenerative to plug braking on overspeed.

A setting of less than 100 will result in the control going into plug braking during an overspeed condition. A setting of greater than 100 will result in the control going into regenerative braking during an overspeed condition. The default setting of 100 will always result in regenerative braking during overspeed.

FUNCTION 14 INTERNAL RESISTANCE COMPENSATION
(Push 14)

This function is used when the Battery Discharge Indicator is present. Adjustment of this function will improve the accuracy of the BDI. In order to determine this setting, the voltage drop of the battery under load must first be calculated by the following method:

1. Record open circuit voltage (V_0) by measuring the voltage at the control positive and negative power terminals.
2. Load the traction motor to 100 amps in 1A and record the voltage (V_L) at the control positive and negative power terminals.
3. Calculate voltage drop (V_{Drop}) as follows:

$$V_{Drop} = V_0 - V_L$$
4. Use the table below to determine the appropriate setting using the calculated V_{Drop} as a reference.

INTERNAL RESISTANCE COMPENSATION
TABLE

Setting	V_{Drop}	Setting	V_{Drop}
2	11.44	17	1.34
3	7.60	18	1.27
4	5.72	19	1.20
5	4.57	20	1.14
6	3.81	21	1.09
7	3.27	22	1.04
8	2.86	23	0.99
9	2.54	24	0.95
10	2.28	25	0.91
11	2.08	26	0.88
12	1.90	27	0.85
13	1.76	28	0.82
14	1.63	29	0.79
15	1.52	30	0.76
16	1.43	31	0.74

FUNCTION 15 BATTERY VOLTS
(Push I5)

In order for the battery discharge indication feature of this control to operate properly, this function must be set to a value between 70 and 80.

The following functions have function numbers larger than the numbers on the Handset keyboard. To access these functions, push the CONT key and the number shown in the instructions at the same time. THE TURF SPEED SWITCH MUST BE OPEN.

FUNCTION 16 BATTERY VOLTAGE TRIP POINT FOR MOTOR CURRENT REDUCTION
(Push CONT1)

This function adjusts the battery voltage trip level at which the armature current begins to decrease to prevent the battery voltage from dipping even lower.

- Range 0 to 255
- Setting 0 to 255
- Calculation $(\text{Setting}/5.29) + 36V = \text{trip volts}$
- Example Setting of 105 = $(105/5.29) + 36 = 55.8 \text{ volts}$

FUNCTION 17 CARD TYPE SELECTION
(Push CONT 2)

This function allows for the selection of the card type for this vehicle's application. This function should always be set to 117 for this control.

FUNCTION 18 LINE CONTACTOR DROP OUT TIME DELAY
(Push CONT 3)

This function allows for the adjustment of the time allowable for the control to be idle before the line contactor opens.

Range	0 to 25.5 seconds
Setting	0 to 255
Resolution	0.1 seconds per set unit
Example:	Setting of 255 = 25.5 seconds

FUNCTION 19 FIELD CURRENT RAMP RATE DURING REGEN/PLUGGING
(Push CONT 4)

This function adjusts the rate at which field current ramps to full value during regenerative or plug braking.

Range	0 to 0.255 seconds
Setting	0 to 255
Resolution	0.001 seconds per set unit
Example:	Setting of 12 = 0.012 seconds

FUNCTION 20 MPH OVER SPEED LIMIT
(Push CONT 5)

This function adjusts the value of the over speed limit of the control.

Resolution	1 MPH per set unit
Example:	Setting of 28 = 28 MPH

Important Note: The function is used to optimize motor and control performance and this setting will be determined by GE and OEM engineers at the time of vehicle development. This setting must not be changed by field personnel without the permission of the OEM.

FUNCTION 21 RATE FIELD CHANGES IN OVERSPEED
(Push CONT 6)

This function adjusts how quickly the control responds to an over speed condition (as defined by the setting value of function 20). A higher setting will result in the control requiring a longer response time to an over speed condition.

Range	0 to 0.255 seconds
Setting	0 to 255
Resolution	0.001 seconds per set unit
Example:	Setting of 2 = 0.002 seconds

Important Note: The function is used to optimize motor and control performance and this setting will be determined by GE and OEM engineers at the time of vehicle development. This setting must not be changed by field personnel without the permission of the OEM.

FUNCTION 23 ERROR COMPENSATION
(Push CONT 8)

This function is used to reduce the ripple in field current due to the interaction between motor field design and the digital field current regulation circuit. The value for this function should be set to 32.

Important Note: The function is used to optimize motor and control performance and this setting will be determined by GE and OEM engineers at the time of vehicle development. This setting must not be changed by field personnel without the permission of the OEM.

FUNCTION 24 FIELD WEAKENING START (or MOTOR KNEE POINT)
(Push CONT 9)

This function allows for setting the armature current at which minimum field current will be achieved.

Range	0 to 350 Amps
Setting	0 to 255
Resolution	1.625 per set unit
Example:	Setting of 47 = 76.38 amps.

Important Note: The function is used to optimize motor and control performance and this setting will be determined by GE and OEM engineers at the time of vehicle development. This setting must not be changed by field personnel without the permission of the OEM.

FUNCTION 25 MONITOR
(Push CONT 10)

This function allows the monitoring of certain control functions by looking directly at the RAM of the microprocessor. Because absolute memory locations need to be known, this function should not be used without detailed instructions from the GE application engineer.

To ensure optimum operation of the control, this function must be left with zero stored in this register.

FUNCTION 26 RATIO OF FIELD TO ARMATURE AMPS

(Push CONT 11)

This function sets the ratio between armature and field current when transitioning from minimum field to maximum field current. The setting represents the quantity of field current changed for each 1 amp of armature current changed.

Max Fld Ref	Max Change	Set	Resolution Per unit value	Example If set at 3
40	.27	0 to 10	0.027 amps	0.081 amps

**FUNCTION 27 HOUR METER MINUTES
(Push CONT 12)**

This function adjusts the number of 30 second intervals registering in the hour meter. This function is typically not set by an OEM, it is usually only read from the register.

Range	0 to 60 minutes
Resolution	0.5 minutes per set unit
Setting	0 to 120
Example	Setting of 60 = 60 x 0.5 = 30 minutes

**FUNCTION 28 STORED STATUS CODE COUNT
POINTER
(Push CONT 13)**

This register contains the location of the last stored status code recorded of the 16 stored status codes. These stored status codes have caused a PMT controller shutdown and/or disruption of normal vehicle operation.

To determine which stored status code was the last one recorded, read the number stored in Function 28. Using the **Memory Map** for your logic card, match the "**stored status code pointer number**" [the number shown in *(bold italics)* in the HS (Handset) number column] on the memory map, with the number obtained from Function 28. This will be the last stored status code recorded.

Note: When scrolling through the stored status code register, the register always starts at status code 1 and scrolls to status code 16. Instructions for scrolling the register are in section 5.3.2 of this instruction booklet.

**FUNCTION 29 HOUR METER TENS AND UNITS
HOURS SET
(Push CONT 14)**

This function allows for the adjustment of the tens and units hours of the hour meter.

Range	0 to 99
-------	---------

Set	0 to 99
Example	<u>9999</u> Hours

**FUNCTION 30 HOUR METER THOUSANDS
AND HUNDREDS HOURS SET
(Push CONT 15)**

This function allows for the adjustment of the thousands and hundreds hours of the hour meter.

Range	0 to 99
Set	0 to 99
Example	<u>9999</u> Hours

Section 5.5 Summary of Current Limit Adjustments

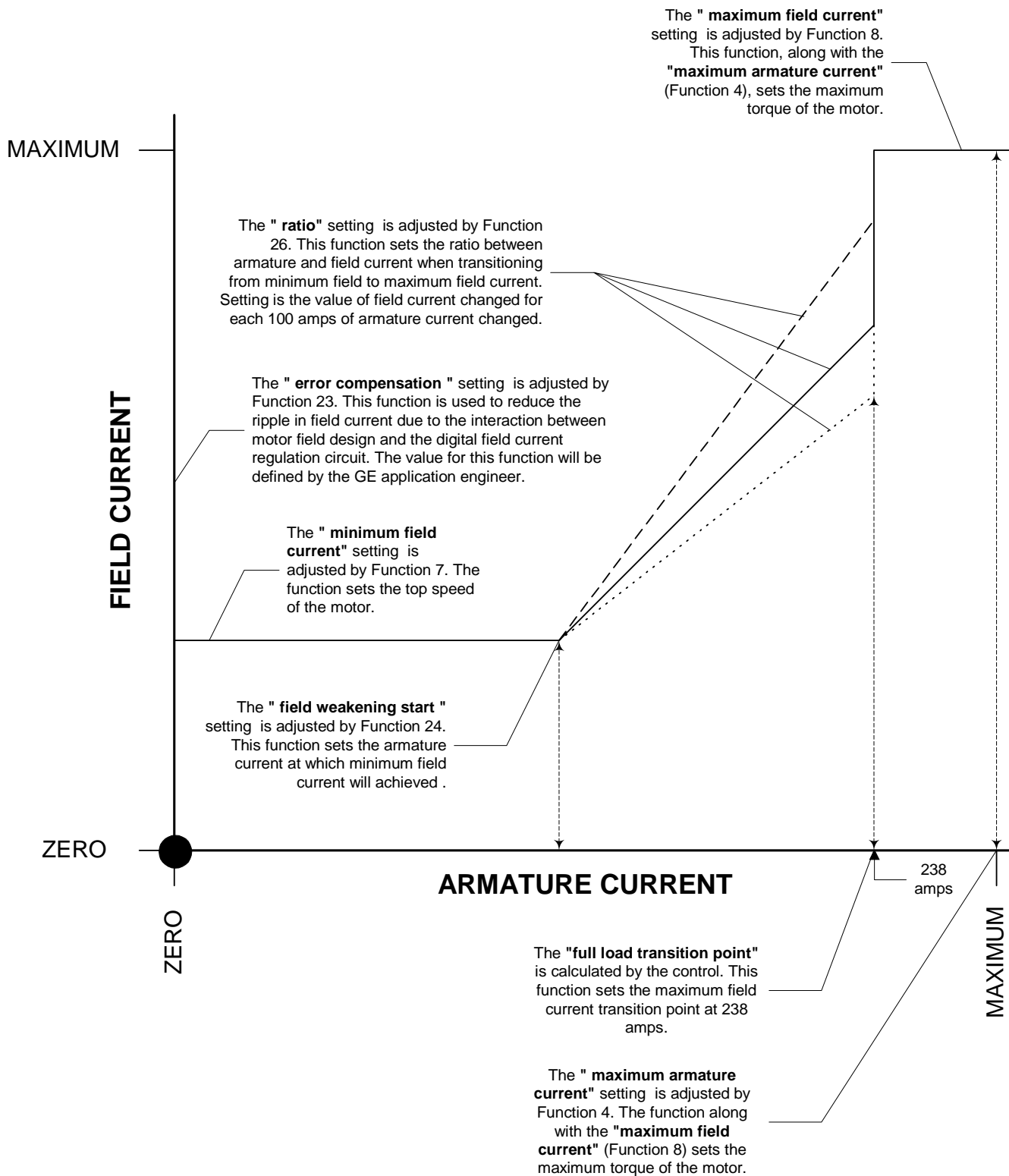

Section 6.0 MEMORY MAP

E ²	Func No.	HS No.	Traction Control Function	Access By	Restrictions
0	1	1	MPH Scaling	HS or PC	None
1	2	2	Creep Speed	HS or PC	None
2	3	3	Armature Acceleration Rate Forward	HS or PC	None
3	4	4	Max Armature Current Limit	HS or PC	None
4	5	5	Response Time of Battery State of Charge Updates	HS or PC	None
5	6	6	Armature Acceleration Rate Reverse	HS or PC	None
6	7	7	Min Field Current	HS or PC	None
7	8	8	Max Field Current	HS or PC	None
8	9	9	Regen Armature Current Limit	HS or PC	None
9	10	10	Field Current for Regen and Plug Braking	HS or PC	None
10	11	11	Turf Speed Limit	HS or PC	None
11	12	12	Reverse Speed Limit	HS or PC	None
12	13	13	Percent Charge Switch Plug to Regen	HS or PC	None
13	14	14	IR Compensation	HS or PC	None
14	15	15	Battery Volts Select	HS or PC	None
15	16	16	Battery Voltage Trip Point for Mtr Current Reduction	HS or PC	None
16	17	17	Card Type Selection	HS or PC	None
17	18	18	Line Contactor Drop Out Time Delay	HS or PC	None
18	19	19	Field Current Ramp Rate During Regen	HS or PC	None
19	20	20	MPH Overspeed Limit	HS or PC	None
20	21	21	Rate Field Changes in Overspeed	HS or PC	None
21	22	22	Pulse Counts	HS or PC	For DD on power up
22	23	23	Error Compensation	HS or PC	None
23	24	24	Field Weakening Start	HS or PC	None
24	25	25	Monitor	HS or PC	GE Temporary Storage
25	26	26	Ratio of Field to Armature Amps	HS or PC	None
26	27	27	Hour Meter Minutes	HS or PC	None
27	28	28	Fault Count Pointer	HS or PC	None
28	29	29	Hour Meter Tens and Units	HS or PC	None
29	30	30	Hour Meter Thousands and Hundreds	HS or PC	None
30	31		Aux HM (Tens/Ones)	PC Only	None
31	32		Aux HM (Thou/Hun)	PC Only	None
32	33	(18)	Stored Status Code #1	PC Only	Reset to Zero Only
33	34		BDI 1	PC Only	Reset to Zero Only
34	35		Hours (Tens/Ones) 1	PC Only	Reset to Zero Only
35	36		Hours (Thou/Hun) 1	PC Only	Reset to Zero Only
36	37	(20)	Stored Status Code #2	PC Only	Reset to Zero Only
37	38		BDI 2	PC Only	Reset to Zero Only
38	39		Hours (Tens/Ones) 2	PC Only	Reset to Zero Only
39	40		Hours (Thou/Hun) 2	PC Only	Reset to Zero Only
40	41	(22)	Stored Status Code #3	PC Only	Reset to Zero Only
41	42		BDI 3	PC Only	Reset to Zero Only
42	43		Hours (Tens/Ones) 3	PC Only	Reset to Zero Only
43	44		Hours (Thou/Hun) 2	PC Only	Reset to Zero Only
44	45	(22)	Stored Status Code #4	PC Only	Reset to Zero Only

E ²	Func No.	HS No.	Traction Control Function	Access By	Restrictions
45	46		BDI 4	PC Only	Reset to Zero Only
46	47		Hours (Tens/Ones) 4	PC Only	Reset to Zero Only
47	48		Hours (Thou/Hun) 4	PC Only	Reset to Zero Only
48	49	(26)	Stored Status Code #5	PC Only	Reset to Zero Only
49	50		BDI 5	PC Only	Reset to Zero Only
50	51		Hours (Tens/Ones) 5	PC Only	Reset to Zero Only
51	52		Hours (Thou/Hun) 5	PC Only	Reset to Zero Only
52	53	(28)	Stored Status Code #6	PC Only	Reset to Zero Only
53	54		BDI 6	PC Only	Reset to Zero Only
54	55		Hours(Tens/Ones) 6	PC Only	Reset to Zero Only
55	56		Hours(Thou/Hun) 6	PC Only	Reset to Zero Only
56	57	(30)	Stored Status Code #7	PC Only	Reset to Zero Only
57	58		BDI 7	PC Only	Reset to Zero Only
58	59		Hours(Tens/Ones) 7	PC Only	Reset to Zero Only
59	60		Hours(Thou/Hun) 7	PC Only	Reset to Zero Only
60	61	(32)	Stored Status Code #8	PC Only	Reset to Zero Only
61	62		BDI 8	PC Only	Reset to Zero Only
62	63		Hours(Tens/Ones) 8	PC Only	Reset to Zero Only
63	64		Hours(Thou/Hun) 8	PC Only	Reset to Zero Only
64	65	(34)	Stored Status Code #9	PC Only	Reset to Zero Only
65	66		BDI 9	PC Only	Reset to Zero Only
66	67		Hours(Tens/Ones) 9	PC Only	Reset to Zero Only
67	68		Hours(Thou/Hun) 9	PC Only	Reset to Zero Only
68	69	(36)	Stored Status Code #10	PC Only	Reset to Zero Only
69	70		BDI 10	PC Only	Reset to Zero Only
70	71		Hours(Tens/Ones) 10	PC Only	Reset to Zero Only
71	72		Hours(Thou/Hun) 10	PC Only	Reset to Zero Only
72	73	(38)	Stored Status Code #11	PC Only	Reset to Zero Only
73	74		BDI 11	PC Only	Reset to Zero Only
74	75		Hours(Tens/Ones) 11	PC Only	Reset to Zero Only
75	76		Hours(Thou/Hun) 11	PC Only	Reset to Zero Only
76	77	(40)	Stored Status Code #12	PC Only	Reset to Zero Only
77	78		BDI 12	PC Only	Reset to Zero Only
78	79		Hours(Tens/Ones) 12	PC Only	Reset to Zero Only
79	80		Hours(Thou/Hun) 12	PC Only	Reset to Zero Only
80	81	(42)	Stored Status Code #13	PC Only	Reset to Zero Only
81	82		BDI 13	PC Only	Reset to Zero Only
82	83		Hours(Tens/Ones) 13	PC Only	Reset to Zero Only
83	84		Hours(Thou/Hun) 13	PC Only	Reset to Zero Only
84	85	(44)	Stored Status Code # 14	PC Only	Reset to Zero Only
85	86		BDI 14	PC Only	Reset to Zero Only
86	87		Hours(Tens/Ones) 14	PC Only	Reset to Zero Only
87	88		Hours(Thou/Hun) 14	PC Only	Reset to Zero Only
88	89	(46)	Stored Status Code # 15	PC Only	Reset to Zero Only
89	90		BDI 15	PC Only	Reset to Zero Only
90	91		Hours (Tens/Ones) 15	PC Only	Reset to Zero Only

E ²	Func No.	HS No.	Traction Control Function	Access By	Restrictions
91	92		Hours (Thou/Hun) 15	PC Only	Reset to Zero Only
92	93	(48)	Stored Status Code #16	PC Only	Reset to Zero Only
94	95		Hours (Tens/Ones) 16	PC Only	Reset to Zero Only
95	96		Hours (Thou/Hun) 16	PC Only	Reset to Zero Only
96	97	48	Not applicable	HS or PC	None
97	98	49	Not applicable	HS or PC	None
98	99	50	Not applicable	HS or PC	None
99	100	51	Not applicable	HS or PC	None
100	101	52	Not applicable	HS or PC	None
101	102	53	Not applicable	HS or PC	None
102	103	54	Not applicable	HS or PC	None
103	104	55	Not applicable	HS or PC	None
104	105	56	Not applicable	HS or PC	None
105	106	57	Not applicable	HS or PC	None
106	107	58	Not applicable	HS or PC	None
107	108	59	Not applicable	HS or PC	None
108	109	60	Not applicable	HS or PC	None
109	110	61	Not applicable	HS or PC	None
110	111	62	Not applicable	HS or PC	None
111	112	63	Not applicable	HS or PC	None
112	113		Secure HM (Tens/Ones)	PC Only	OEM Read Only
113	114		Secure HM (Thou/Hun)	PC Only	OEM Read Only
114	115		Secure Aux HM (Tens/Ones)	PC Only	OEM Read Only
115	116		Secure Aux HM (Thou/Hun)	PC Only	OEM Read Only
116	117		Field Offset	PC Only	GE Future Use
117	118		Field Offset	PC Only	GE Future Use
118	119		Armature Offset	PC Only	GE Future Use
119	120		Reserved	PC Only	GE Future Use
120	121		OEM Use	PC Only	None
121	122		OEM Use	PC Only	None
122	123		OEM Use	PC Only	None
123	124		OEM Use	PC Only	None
124	125		OEM Use	PC Only	None
125	126		OEM Use	PC Only	None
126	127		OEM Use	PC Only	None
127	128		OEM Use	PC Only	None

Numbers in ***(bold italics)*** are Stored Status Code pointers.