

**SEPARATELY EXCITED (SX) TRANSISTORIZED DUAL MOTOR CONTROLLERS  
 AND SERIES PUMP MOTOR CONTROL  
 INSTALLATION AND OPERATION MANUAL**  
*(IC3645SR4U454Z2, IC3645SR3U454Z2, and IC3645SP4U450Z1)*

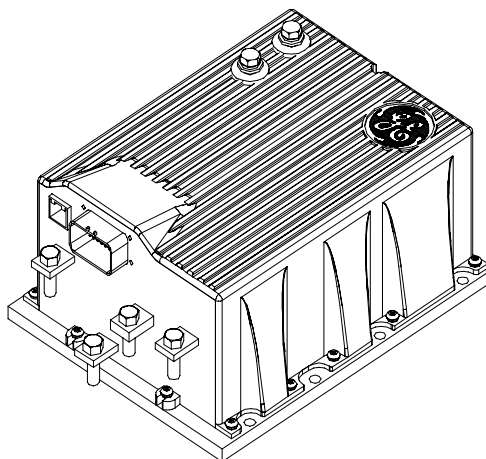

*Note: The information contained herein is intended to assist OEM's, Dealers and Users of electric vehicles in the application, installation and service of GE solid-state controllers. This manual does not purport to cover all variations in OEM vehicle types. Nor does it provide for every possible contingency to be met involving vehicle installation, operation or maintenance. For additional information and/or problem resolution, please refer the matter to the OEM vehicle manufacturer through his normal field service channels. Do not contact GE directly for this assistance.*

**Table of Contents**

Copyright by General Electric Company January 1999

<b>Section 1.0</b>	<b>INTRODUCTION .....</b>	<b>5</b>
1.1	Motor Characteristics .....	5
1.2	Solid-State Reversing .....	6
1.3	Flexible System Application.....	6
1.4	More Features with Fewer Components .....	6
<b>Section 2.0</b>	<b>FEATURES OF SX FAMILY OF MOTOR CONTROLLERS .....</b>	<b>7</b>
2.1	Performance .....	7
2.1.1	Oscillator Card Features .....	7
2.1.1.a	Standard Operation .....	7
2.1.1.b	Proportional Operation for Dual Motor Vehicles .....	7
2.1.1.c	Creep Speed.....	7
2.1.1.d	Controlled Acceleration and 1A Time.....	7
2.1.2	Current Limit .....	8
2.1.3	Braking.....	8

**Table of Contents ( Continued )**

2.1.3.a	Plug Braking .....	8
2.1.3.b	Regenerative Braking to Zero Speed .....	8
2.1.3.c	Pedal Position Plug Braking .....	8
2.1.3.d	Auto Braking.....	8
2.1.3.e	Brake Pedal Regenerative Braking .....	8
2.1.4	Auxiliary Speed Control.....	8
2.1.4.a	Field Weakening.....	8
2.1.4.b	Speed Limits .....	8
2.1.5	Ramp Operation .....	9
2.1.5.a	Ramp Start .....	9
2.1.5.b	Anti-Rollback .....	9
2.1.6	Steer Pump Contactor Time Delay .....	9
2.1.7	On-Board Coil Drivers and Internal Coil Suppression .....	9
2.2	System Protective Override .....	9
2.2.1	Static Return to Off (SRO) .....	9
2.2.2	Accelerator Volts Hold Off.....	9
2.2.3	Pulse Monitor Trip (PMT).....	9
2.2.4	IA Current Drop Out.....	9
2.2.5	IA Thermal Hold Off.....	9
2.2.6	Thermal Protector (TP).....	10
2.2.7	Low Voltage .....	10
2.3	Diagnostics.....	10
2.3.1	Systems Diagnostics.....	10
2.3.2	Status Codes.....	10
2.3.2.a	Standard Codes.....	10
2.3.2.b	Stored Codes .....	10
2.3.3	Hourmeter Readings .....	10
2.3.3.a	Maintenance Alert and Speed Limit .....	10
2.3.4	Battery Discharge Indication (BDI).....	10
2.3.4.a	Internal Resistance Compensation .....	10
2.3.5	Handset .....	10
2.3.6	RS-232 Communication Port .....	11
2.3.6.a	Dash Display Interaction Modes .....	11
2.3.7	Circuit Board Coil Driver Modules.....	11
2.3.8	Truck Management Module (TMM) .....	11
2.4	Hydraulic Pump Control.....	11
<b>Section 3.0</b>	<b>ORDERING INFORMATION, ELEMENTARY AND OUTLINE DRAWINGS.....</b>	<b>13</b>
3.1	Ordering Information for Separately Excited Controls.....	13
3.2	Outline: SR-3 Package Size.....	14
3.3	Outline: SX-3 Package Size.....	15
3.4	Standard Dual Motor Proportioning Drive Elementary.....	16
3.5	Standard Pump Elementary.....	17
3.6	Standard Dual Motor Proportioning Drive Input / Output List .....	18
<b>Section 4.0</b>	<b>TROUBLESHOOTING AND DIAGNOSTIC STATUS CODES.....</b>	<b>19</b>
4.1	General Maintenance Instructions.....	19
4.2	Cable Routing and Separation .....	19
4.2.1	Application Responsibility .....	19

**Table of Contents ( Continued )**

4.2.2	Signal/Power Level Definitions .....	19
4.2.2.a	Low Level Signals (Level L) .....	19
4.2.2.b	High Level Signals (Level H) .....	20
4.2.2.c	Medium-Power Signals (Level MP) .....	20
4.2.2.d	High-Power Signals (Level HP) .....	20
4.2.3	Cable Spacing Guidelines .....	20
4.2.3.a	General Cable Spacing .....	20
4.2.4	Cabling for Vehicle Retrofits .....	20
4.2.5	RF Interference .....	20
4.2.6	Suppression .....	20
4.3	Recommended Lubrication of Pins and Sockets Prior to Installation .....	20
4.4	General Troubleshooting Instructions .....	21
4.5	Traction Controller Status Codes .....	23-42
4.6	TMM Module Status Codes .....	42-47
4.7	Pump Control Status Codes .....	47-55
<b>Section 5.0</b>	<b>TRUCK MANAGEMENT MODULE (TMM) .....</b>	<b>56</b>
5.1	General Features .....	56
5.2	Operation .....	56
5.3	Installation .....	56
5.4	Connection Diagrams .....	56
5.4.1	TMM7A Card Connections .....	56
5.4.2	TMM7A Typical Brush Wear Sensor Connections .....	56
5.4.3	TMM Pump Control Connections .....	57
5.4.4	Typical Brush Wear Sensor Connections For Pump Control .....	57
5.5	TMM7A Outline Diagrams .....	57
<b>Section 6.0</b>	<b>SX FAMILY - GE HANDSET INSTRUCTIONS .....</b>	<b>58</b>
6.1	General Features .....	58
6.2	Purpose/Setup Functions .....	58
6.3	Setup Function Procedures .....	59
6.3.1	Setup Mode .....	59
6.3.2	Status Code Scrolling .....	59
6.3.3	SX Handset Plug Connections & Outline Drawing .....	59
6.4	Setup Functions for Traction Controller ..	60-65
6.5	Summary of Current Limit Adjustments .....	66
<b>Section 7.0</b>	<b>DASH DISPLAYS .....</b>	<b>67</b>
7.1	Application .....	67
7.2	Standard Dash Displays .....	67
7.3	Interactive Dash Displays .....	67
7.4	Start-up Display Sequence .....	68
7.5	Outline Drawings .....	68
<b>Section 8.0</b>	<b>TURN ANGLE POTENTIOMETER INSTALLATION .....</b>	<b>69</b>
8.1	General .....	69
8.2	270 Degree Potentiometer Input .....	70
8.3	Turn Angle Input Volts vs. Steer Wheel Degrees vs. Handset Reading .....	71

Table of Contents (Continued)

Section 9.0	MEMORY MAPS.....	72
9.1	Typical Memory Map for Single Motor and DM Proportioning Control .....	72-74

## Section 1. INTRODUCTION

### Section 1.1 Motor Characteristics

The level of sophistication in the controllability of traction motors has changed greatly over the past several years. Vehicle manufacturers and users are continuing to expect more value and flexibility in electric vehicle motor and control systems as they are applied today. In order to respond to these market demands, traction system designers have been forced to develop new approaches to reduce cost and improve functions and features of the overall system. Development is being done in a multi-generational format that allows the market to take advantage of today's technology, while looking forward to new advances on the horizon. GE has introduced a second generation system using separately excited DC shunt wound motors. The separately excited DC motor system offers many of the features that are generally found on the advanced AC systems. Historically, most electric vehicles have relied have on series motor designs because of their ability to produce very high levels of torque at low speeds. But, as the demand for high efficiency systems increases, i.e., systems that are more closely applied to customers' specific torque requirements, shunt motors are now often being considered over series motors. In most applications, by independently controlling the field and armature currents in the separately excited motor, the best attributes of both the series and the shunt wound motors can be combined.

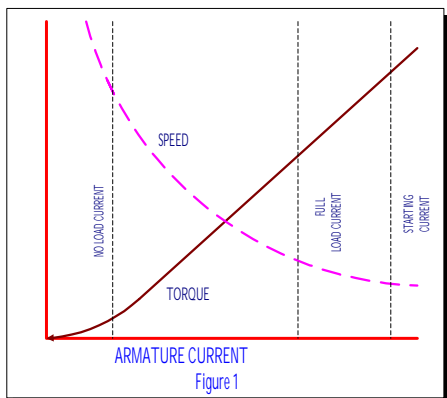

As shown in from the typical performance curves of Figure 1, the high torque at low speed characteristic of the series motor is evident.

In a shunt motor, the field is connected directly across the voltage source and is therefore independent of variations in load and armature current. If field strength is held constant, the torque developed will vary directly with the armature current. If the mechanical load on the motor increases, the motor slows down, reducing the back EMF (which depends on the speed, as well as the constant field strength). The reduced back EMF allows the armature

current to increase, providing the greater torque needed to drive the increased mechanical load. If the mechanical load is decreased, the process reverses. The motor speed and the back EMF increase, while the armature current and the torque developed decrease. Thus, whenever the load changes, the speed changes also, until the motor is again in electrical balance.

In a shunt motor, the variation of speed from no load to normal full load on level ground is less than 10%. For this reason, shunt motors are considered to be constant speed motors (Figure 2).

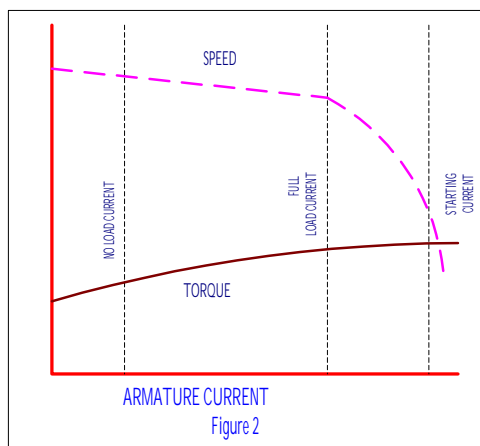

In the separately excited motor, the motor is operated as a fixed field shunt motor in the normal running range. However, when additional torque is required, for example, to climb non-level terrain, such as ramps and the like, the field current is increased to provide the higher level of torque. In most cases, the armature to field ampere turn ratio can be very similar to that of a comparable size series motor (Figure 3.)

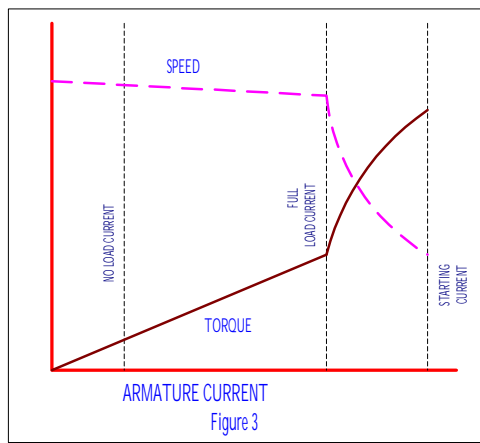

Aside from the constant horsepower characteristics described above, there are many other features that provide increased performance and lower cost. The

following description provides a brief introduction to examples of some of these features.

### Section 1. 2 Solid-State Reversing

The direction of armature rotation on a shunt motor is determined by the direction in which current flows through the field windings. Because of the of the shunt motor field only typically requires about 10% of the armature current at full torque, it is normally cost effective to replace the double-pole, double-throw reversing contactor with a low power transistor H-Bridge circuit (Figure 4).

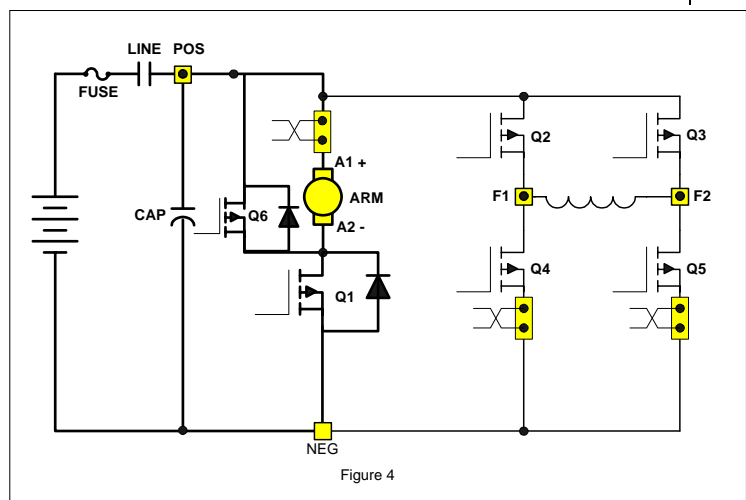

Figure 4

By energizing the transistors in pairs, current can be made to flow in either direction in the field. The field and armature control circuits typically operate at 12KHZ to 15KHZ, a frequency range normally above human hearing. This high frequency coupled with the elimination of directional contactors, provides very quiet vehicle operation.

The line contactor is normally the only contactor required for the shunt motor traction circuit. This contactor is used for both pre-charge of the line capacitors and for emergency shut down of the motor circuit, in case of problems that would cause a full motor torque condition. The line can be energized and de-energized by the various logic combinations of the vehicle, i.e. activate on key, seat or start switch closure, and de-energize on time out of idle vehicle. Again, these options add to the quiet operation of the vehicle.

### Section 1. 3 Flexible System Application

Because the shunt motor controller has the ability to control both the armature and field circuits independently, the system can normally be adjusted for maximum system efficiencies at certain operating parameters. Generally speaking, with the ability of independent field and

armature, the motor performance curve can be maximized through proper control application.

### Section 1. 4 More Features with Fewer Components

Field weakening with a series wound motor is accomplished by placing a resistor in parallel with the field winding of the motor. Bypassing some of the current flowing in the field into the resistor causes the field current to be less, or weakened. With the field weakened, the motor speed will increase, giving the effect of "overdrive". To change the "overdrive speed", it is necessary to change the resistor value. In a separately excited motor, independent control of the field current provides for infinite adjustments of "overdrive" levels, between motor base speed and maximum weak field. The desirability of this feature is enhanced by the elimination of the contactor and resistor required for field weakening with a series motor.

With a separately excited motor, overhauling speed limit, or downhill speed, will also be more constant. By its nature, the shunt motor will try to maintain a constant speed downhill. This characteristic can be enhanced by increasing the field strength with the control. Overhauling load control works in just the opposite way of field weakening, armature rotation slows with the increase of current in the field. An extension of this feature is a zero-speed detect feature which prevents the vehicle from free-wheeling down an incline, should the operator neglect to set the brake.

Regenerative braking (braking energy returned to the battery) may be accomplished completely with solid-state technology. The main advantage of regenerative braking is increased motor life. Motor current is reduced by 50% or more during braking while maintaining the same braking torque as electrical braking with a diode clamp around the armature. The lower current translates into longer brush life and reduced motor heating. Solid state regenerative braking also eliminates a power diode, current sensor and contactor from the circuit.

For GE, the future is now as we make available a new generation of electric traction motor systems for electric vehicles having separately excited DC shunt motors and controls. Features that were once thought to be only available on future AC or brushless DC technology vehicles systems are now achievable and affordable.

## Section 2. FEATURES OF SX FAMILY OF TRANSISTOR MOTOR CONTROLLERS

### Section 2.1 Performance

#### Section 2.1.1 Oscillator Card Features

##### Section 2.1.1.a Standard Operation

The oscillator section of the card has two adjustable features, creep speed and minimum field current. With the accelerator at maximum ohms or volts, the creep speed can be adjusted by Function 2 of the Handset or a trimpot. The field control section allows the adjustment of the field weakening level in order to set the top speed of the motor. This top speed function (Minimum Field Current) is enabled when the armature current is less than the value set by Function 24 and the accelerator input voltage is less than 1 volt. Top Speed can be adjusted by Function 7 of the Handset or a trimpot.

The percent on-time has a range of approximately 0 to 100 percent. The SX controllers operate at a constant frequency and the percent on-time is controlled by the pulse width of the voltage / current applied to the motor circuits.

##### Section 2.1.1.b Proportional Operation for Dual Motor Vehicles

A key performance advantage of this control is the ability to achieve actual "proportioning" of motor speed. In a non-proportioning, or single control, system when the vehicle starts to turn, the outside drive wheel turns in a larger circle than the inside wheel. Depending on the geometry of the vehicle, at some degree of turn angle, the inside wheel must slow down to prevent scrubbing of the wheel. This is accomplished on single control system by disconnecting the inside motor and letting the wheel "free wheel" or "float" at whatever speed is dictated by the outside wheel that is still under power. The main disadvantage of this system is that no torque is available on that motor when the inside wheel is in the "free-wheel" mode, and performance in a turn is reduced. When the steer wheel nears to the 90° turn angle, the inside motor is re-connected in the opposite direction of the outside. At this point, torque is returned to the inside wheel and the speed is the same on both motors.

With two controls, the speed of each motor can be regulated independently. The driver controls the speed of the outside wheel with the accelerator input signal. The inside wheel speed is controlled by the turn angle of the steer wheel. A potentiometer is attached to the steer wheel in order to communicate the steer angle to the controllers. During vehicle manufacture, software selection identifies each control for its application as a right or left control.

The controls are physically identical, and it is only software that separates a right from a left control or differentiates a control for a dual motor application from one intended for a single motor vehicle. As the steer reaches some pre-selected turn angle, approximately 20°, the speed of the inside wheel decrease proportionally to the speed of the outside wheel. This proportional decline will continue on a linear path until the steer angle reaches another pre-determine angle of, approximately 65°.

At this point, the inside wheel will stop, as the steer angle is increased toward the 90° point, the inside wheel will reverse direction and start to accelerate proportionally in speed. As the steer angle reaches the 90° point, the inside wheel speed will be the same as that of the outside wheel. During this entire turn, except for several degrees when the motor was stopped to change direction, torque was always present on the inside wheel, providing a smoother ride throughout the turning radius of the vehicle.

Details for adjustment of the steer angle potentiometer can be found in Appendix A of this manual.

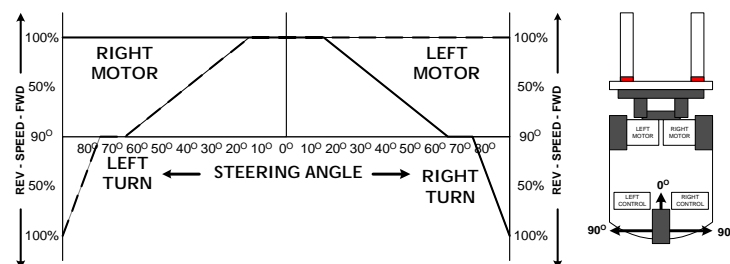

##### Section 2.1.1.c Creep Speed

With the accelerator at maximum ohms or volts (approximately 3.7 to 3.5 VDC), the creep speed can be adjusted by Function 2 of the Handset. At creep speed, the ON time can decrease to approximately 5%, with the OFF time at approximately 95%. At full transistor operation, this condition will be reversed (short OFF time, long ON time). This variation of ON and OFF time of the oscillator varies the voltage applied to the motor, thereby varying the speed of the motor for a given load.

##### Section 2.1.1.d Control Acceleration and IA Time

This feature allows for adjustment of the rate of time it takes for the control to accelerate to 100% applied battery voltage to the motor on hard acceleration. The IA contactor will automatically close 0.2 seconds after the controlled acceleration stops and the accelerator input is less than 0.5 volts or less than 200 ohms. Armature C/A is adjusted by Function 3 from 0.1 to 22 seconds.

## Section 2.1.2 Current Limit

This circuit monitors motor current by utilizing sensors in series with the armature and field windings. The information detected by the sensor is fed back to the card so that current may be limited to a pre-set value. If heavy load currents are detected, this circuit overrides the oscillator and limits the average current to a value set by Function 4 and Function 8 of the Handset. The C/L setting is based on the maximum thermal rating of the control. Because of the flyback current through 3REC, the motor current is usually greater than battery current, except at 100% ON time, or when the IA contactor is closed.

## Section 2.1.3 Braking

### Section 2.1.3.a Plug Braking

Slow down is accomplished when reversing direction by providing a small amount of retarding torque for deceleration. If the vehicle is moving, and the directional lever is moved from one direction to the other, the plug signal is initiated. Once the plug signal has been initiated, the field is reversed, and the armature current is regulated to the plug current limit as set by Function 6. Armature current is regulated by increasing the field current as the vehicle slows down. Once the field current reaches a preset value, set by Function 10, and armature plug current can no longer be maintained, the braking function is canceled, and the control reverts back to motoring. All energy produced by the motor during plugging is dumped as heat in the motor in this braking mode.

### Section 2.1.3.b Regenerative Braking to Zero Speed

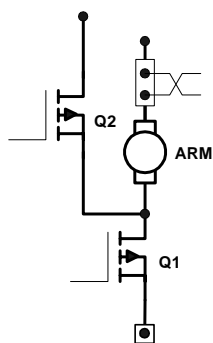

Slow down is accomplished when reversing direction by providing a small amount of retarding torque for deceleration. If the vehicle is moving, and the directional lever is moved from one direction to the other, the regen signal is initiated. Once the regen signal has been initiated, the field current is increased. Armature current is regulated to the regen current limit as set by Function 9. As the vehicle slows down, the field current continues to increase, and transistor Q2 begins to chop. The field current will increase until it reaches a preset value set by Function 10, and transistor Q2 on-time will increase until it reaches 100% on-time. Once both of the above conditions have been met, and regen current limit can no longer be maintained, the braking function is canceled. The fields will then reverse, and the control reverts back to motoring.

As the vehicle slows down, the field current continues to increase, and transistor Q2 begins to chop. The field current will increase until it reaches a preset value set by Function 10, and transistor Q2 on-time will increase until it reaches 100% on-time. Once both of the above conditions have been met, and regen current limit can no longer be maintained, the braking function is canceled. The fields will then reverse, and the control reverts back to motoring.

Part of the energy produced by the motor during regen is returned to the battery, and part is dumped in the motor as heat.

### Section 2.1.3.c Pedal Position Plug Braking

This feature allows control of the plugging distance based on pedal position when there has been a "directional switch" change. Pedal position will reduce the plugging current to the "value set by this function" as the accelerator is returned to the creep speed position. Maximum plug current is obtained with the accelerator in the top speed position. This feature is adjustable by using Function 16 on the Handset.

### Section 2.1.3.d Auto Braking

This feature can be setup with the Handset using Function 17 to select "Auto Plug/Regen". This feature is enabled by initiating a "neutral position" using either the directional switch or the accelerator switch. Once activated, Auto Braking operates similar to Pedal Position Plug Braking and is adjusted by using Function 16 of the Handset.

### Section 2.1.3.e Brake Pedal Regenerative Braking

This feature sets or varies the amount of REGEN current with AUTO-REGEN braking feature. The current is variable through the use of a pot on the brake pedal to provide a minimum AUTO-REGEN braking level at pedal up, but increasing as the pedal is depressed. A set level of REGEN CURRENT LIMIT is available with a set resistor on the brake pedal. An open input with either adjustment mode a pot or resistor will allow coast until either is selected. Minimum REGEN CURRENT LIMIT requires a 4200 ohm resistor input (minimum level 50 amp). Maximum REGEN CURRENT LIMIT requires a 330 ohm resistor input.

## Section 2.1.4 Auxiliary Speed Control

### Section 2.1.4.a Field Weakening

This function allows the adjustment of the field weakening level in order to set the top speed of the motor. The function is enabled when the armature current is less than the value set by Function 24 and the accelerator input voltage is less than 1 volt. It is important to note that this function is used to optimize motor and control performance, and this setting will be determined by GE and OEM engineers at the time of vehicle development. This setting must not be changed by field personnel without the permission of the OEM.

### Section 2.1.4.b Speed Limits

This feature provides a means to control speed by limiting motor volts utilizing three "adjustable speed limits", initiated by individual limit switches. The NC switches are

connected between input points on the control card and battery negative. The lower motor volt limit always takes priority when more than one switch input is open. This motor volt limit regulates top speed of the transistor controller, but actual truck speed will vary at any set point depending on the loading of the vehicle. Each speed limit can be adjustable with the Handset using Functions 11, 12, and 13, for speed limits SL1, SL2, and SL3 respectively. SL1 is active in all card types and must be disabled with the Handset if speed limits are not used.

### Section 2.1.5 Ramp Operation

#### Section 2.1.5a Ramp Start

This feature provides maximum control torque to restart a vehicle on an incline. The memory for this function is the directional switch. When stopping on an incline, the directional switch must be left in its original or neutral position to allow the control to initiate full power when restarted. The accelerator potentiometer input will modulate ramp start current.

#### Section 2.1.5b Anti-Rollback

This feature provides retarding torque to limit rollback speed in the non-travel direction when the ACC pedal is released when stopping on a grade, or when the brake pedal is released when starting on a grade. This feature forces the vehicle to roll very slowly down the grade when accelerator or brake is released. Because the vehicle can gain significant speed during roll-back, the torque needed to re-start on the ramp is lower than an unrestricted roll-back speed.

#### Section 2.1.6 Steer Pump Contactor Time Delay

This feature provides two options for SP time delay. Option 1 provides a 0.5 to 63 second time delayed drop out of the steer pump contactor when the Forward or Reverse directional switch is opened. This Option 1 is overridden by a 1.5 second time delayed drop out whenever the seat switch is opened. Option 2 provides a 0.5 to 63 second time delayed drop out of the SP contactor when the seat switch is opened.

#### Section 2.1.7 On-Board Coil Drivers & Internal Coil Suppression

Coil drivers for the LINE and SP or BYPASS contactors are on-board the control card. These contactors must have coils rated for the vehicle battery volts.

### Section 2.2 System Protective Override

#### Section 2.2.1 Static Return to Off (SRO)

This inherent feature of the control is designed to require the driver to return the directional lever to the neutral position anytime he leaves the vehicle and returns. Additionally, if the seat switch or key switch is opened, the control shuts off and cannot be restarted until the directional lever is returned to neutral. A time delay of approximately 2 seconds is built into the seat switch input to allow momentary opening of the seat switch, if a bump is encountered.

#### Section 2.2.2 Accelerator Volts Hold Off

This feature checks the voltage level at the accelerator input whenever the key switch or seat switch is activated. If, at start up, the voltage is less than 3.0 volts, the control will not operate. This feature assures that the control is calling for low speed operation at start up.

#### Section 2.2.3 Pulse Monitor Trip (PMT)

The PMT design contains three features which shut down, or lock out, control operation if a fault conditions occurs that would cause a disruption of normal vehicle operation:

- Look ahead
- Look again
- Automatic look again and reset

The PMT circuit will not allow the control to start under the following conditions:

- The control monitors both armature and field FET's at start-up and during running.
- The control will not allow the line contactor to close at start-up, or will drop it out during running, if either the armature or field FET's are defective, so as to cause uncontrolled truck movement.

#### Section 2.2.4 IA Current Drop Out

This adjustable feature can be set to open the IA contactor if the traction motor is subject to excessive currents. The dropout is adjustable with Function 6 using the Handset. Once the control has dropped out the IA contactor due to excessive current, the directional or accelerator switch must be returned to neutral to reset the dropout circuit and allow the control to pick up the IA contactor again. Using this feature may reduce the IA contactor tip life, therefore, it should be used only where needed to protect the motor.

#### Section 2.2.5 IA Thermal Hold Off

This feature prevents the 1A contactor from closing when the vehicle is in severe thermal cutback. When the control

goes into severe cutback, the "Must Pulse To Time" feature will inhibit the IA timer.

### Section 2.2.6 Thermal Protector (TP)

This temperature sensitive device is internal to the power transistor (Q1) module. If the transistor's temperature begins to exceed the design limits, the thermal protector will lower the maximum current limit, and maintain the transistors within their temperature limits. Even at a reduced current limit, the vehicle will normally be able to reach sufficient speed to initiate 1A operation, thereby allowing the control to cool. As the control cools, the thermal protector will automatically reset, returning the control to full power.

### Section 2.2.7 Low Voltage

Batteries under load, particularly if undersized or more than 80 percent discharged, will produce low voltages at the control terminals. The SX control is designed for use down to 50 percent of a nominal battery voltage of 36-84 volts, and 75 percent of a nominal battery voltage of 24 volts. Lower battery voltage may cause the control to operate improperly, however, the resulting PMT should open the Line contactor, in the event of a failure.

## Section 2.3 Diagnostics

### Section 2.3.1 Systems Diagnostics

The control detects the system's present operating status and can be displayed to either the Dash Display or the Handset. There are currently over 70 status codes that are available with SX systems using Traction and Pump controls and Truck Management Module (TMM). Along with the status code display from the TMM, the SX control is capable of reducing the current to the motor, alerting the operator of a critical fault condition.

### Section 2.3.2 Status Codes

#### Section 2.3.2a Standard Status Codes

The SX traction control has over 30 Status Codes that assist the service technician and operator in trouble shooting the vehicle. If mis-operation of the vehicle occurs, a status code will be displayed on the Dash Display for vehicles so equipped, or be available by plugging the Handset into the "y" plug of the logic card.

With the status code number, follow the procedures outlined in DIAGNOSTIC STATUS CODES to determine the problem and a solution.

Note: The Status Code Instruction Sheets do not purport to cover all possible causes of a display of a "status code".

They do provide instructions for checking the most direct inputs that can cause status codes to appear.

### Section 2.3.2.b Stored Status Codes

This feature records the last 16 "Stored Status Codes" that have caused a PMT controller shut down and/or disrupted normal vehicle operation. (PMT type faults are reset by cycling the key switch). These status codes, along with the corresponding BDI and hourmeter readings, can be accessed with the Handset, or by using the RS 232 communications port and dumping the information to a Personal Computer terminal.

### Section 2.3.3 Hourmeter Readings

This feature will display the recorded hours of use of the traction and pump control to the Dash Display each time the key switch is turned off.

#### Section 2.3.3.a Maintenance Alert & Speed Limit

This feature is used to display Status Code 99 and/or activate a speed limit when the vehicle operating hours match the hours set into the maintenance alert register. This feature is set with the Handset using Functions 19, 20 and 21. The operator is alerted that maintenance on the vehicle is required.

### Section 2.3.4 Battery Discharge Indication (BDI)

The latest in microprocessor technology is used to provide accurate battery state of charge information and to supply passive and active warning signals to the vehicle operator. Features and functions:

- Displays 100 to 0 percent charge.
- Display blinks with 20% charge. Disables pump circuit with 10% charge. Auto ranging for 36/48 volt operation. Adjustable for use on 24 to 80 volts.

#### Section 2.3.4.a Internal Resistance Compensation

This feature is used when the Battery Discharge Indicator is present. Adjustment of this function will improve the accuracy of the BDI.

### Section 2.3.5 Handset

This is a multi-functional tool used with the LX, ZX, and SX Series GE solid state controls. The Handset consists of a Light Emitting Diode (LED) display and a keyboard for data entry. Note, for ordering purposes, a separate Handset part is required for SX controls.

Features and functions:

- Monitor existing system status codes for both traction and pump controls. Monitor intermittent random status codes.
- Monitor battery state of charge, if available.
- Monitor hourmeter reading on traction and pump controls. Monitor or adjust the control functions.

### Section 2.3.6 RS 232 Communication Port

This serial communication port can be used with Interactive Custom Dash Displays to allow changes to vehicle operating parameters by the operator. Or, it can be used by service personnel to dump control operating information and settings into a personal computer program.

#### Section 2.3.6.a Interactive Dash Display Modes

The Interactive Custom Dash Display allows the operator to select the best vehicle performance for changing factory (task) conditions. There are four (4) "operator interaction modes" that can be selected by depressing a push button on the dash display.

From the Dash Display, the operator may select any of four pre-set interactive modes consisting of (4) Controlled Acceleration levels, (4) Field Weakening levels and (4) Speed Limits.

These interactive modes are "pre-set" using the Handset (Functions 48-62) or a personal computer (Functions 97-112). This feature allows the operator to select the best vehicle performance for changing factory (task) conditions.

### Section 2.3.7 Circuit Board Coil Driver Modules

Coil drivers are internal to the control card, and are the power devices that operate the Line, 1A and SP contactor coils. On command from the control card, these drivers initiate opening and closing the contactor coils. All driver modules are equipped with reverse battery protection, such that, if the battery is connected incorrectly, the contactors can not be closed electrically.

### Section 2.3.8 Truck Management Module (TMM)

The Truck Management Module is a multifunction accessory card (IC3645TMM7A), or an integral function of the GE Pump controls when used with the SX Traction control. The Module provides the OEM the ability to initiate status codes or operator warning codes to be displayed on the Dash Display, whenever a normally open switch or sensor wire provides a signal to the Module.

The TMM Module can be used to display a separate status code indicating over-temperature of traction motors, hydraulic motors, or any other device or system that can activate a switch that closes.

The TMM Module can also be used as a Brush Wear Indicator (BWI). The Brush Wear Indicator is designed to detect a "worn out brush" and display a fault code on the Dash Display to warn maintenance personnel that the motor brushes need to be replaced before they wear to the point of causing destructive damage to the motor commutator surface.

### Section 2.4 Hydraulic Pump Control

This hydraulic motor controller consists of the following features:

- Four speeds, adjustable from 0 to 100% motor volts. Fixed speeds actuated by switch closure to negative.
- P1A bypass contactor (if required)
- Variable resistor input (5K-0 ohms). Control starts when input is reduced to below 3.5 volts.
- PMT functions available when a pump contactor is used.
- Current limit and controlled acceleration adjustable.
- Battery Discharge Indicator interrupt compatible.

Operation of voltage regulator card: This card provides the basic functions required for controlling the pump control, optional contactors, and PMT functions. Battery positive is applied through a main control fuse to the key switch, energizing the control card power supply input to P1.

When a pump contactor is used, PMT operation is the same as outlined for the traction controllers.

The four speed (motor volts) reference points P12, P19, P20 AND P21 are selected by connecting these points independently to battery negative.

The first speed is obtained by closing Speed Limit I (P12) to control negative. SL1 is adjustable by Function 11 using the Handset to adjust motor voltage from 0 to 100%. The specified motor volts will be regulated, however, the magnitude of motor current will vary depending on the loading of the vehicle.

The second speed is obtained by closing SL2 (P19) to control negative. SL2 is adjusted using the Handset and Function 12 similar to SL1.

The third speed is obtained by closing SL3 (P20) to control negative. SL3 is adjusted using the Handset and Function 13 similar to SL1.

The fourth speed is obtained by closing SL 4 (P21) to control negative. SL4 is adjusted using the Handset and

Function 14 similar to SLI. PIA will close 0.2 seconds after controlled acceleration stops. Speed Limit 4 (Function 14) must be activated and set to >250 to enable the optional P 1 A contactor.

If more than one Speed Limit is activated, the selected speed with the highest motor volts will override the low motor volt speed. The current limit circuit is adjustable and operates the same as the traction current limit.

The controlled acceleration circuit is adjustable and operates the same as the traction circuit. Adjustment range is from 0.1 to 5.5 seconds.

The variable resistor input will override the fixed motor volt limits set by the four (4) adjustable Speed Limits. It will vary motor volts above the set limits up to full motor volts, and closes P1A as resistance is decreased to less than 200 ohms.

The Battery Discharge Indicator (BDI) interrupt will disable the hydraulic controller if the connection at P10 loses the 12 volt signal from the traction control. BDI interrupt can be disabled by Function 17 using the Handset. Select card type with or without BDI function.

**Section 3.0 ORDERING INFORMATION, ELEMENTARY AND OUTLINE DRAWINGS**

**Section 3.1 Ordering Information for Separately Excited Controls**

Example:

<b>Part Number:</b>	<b>IC3645</b>	<b>SE</b>	<b>4</b>	<b>D</b>	<b>33</b>	<b>2</b>	<b>C3</b>
Argument Number:	01	02	03	04	05	06	07

**Argument 01:** Basic Electric Vehicle Control Number

**Argument 02:** Control Type:  
 SH = Separately Excited Control ( Plugging )  
 SR = Separately Excited Control ( Regen to Zero )

**Argument 03:** Operating Voltage:

1 = 120 volts	5 = 36/48 volts
2 = 24 volts	6 = 24/36 volts
3 = 36 volts	7 = 72/80 volts
4 = 48 volts	

**Argument 04:** Package Size:

D = 6.86" X 6.67"
R = 6.86" X 8.15"
U = 8.66" X 8.13"
W = 8.66" X 10.83"

**Argument 05:** Armature Current  
 ( 2 characters )

22 = 220 Amps
33 = 330 Amps
40 = 400 Amps

etc.

**Argument 06:** Field Current  
 ( 1 character )

2 = 20 Amps
3 = 30 Amps
4 = 40 Amps

etc.

**Argument 07:** Customer / Revision

A1 = Customer A / Revision 1
B1 = Customer B / Revision 1

etc.

Section 3.2 Outline: SR-3 Package Size

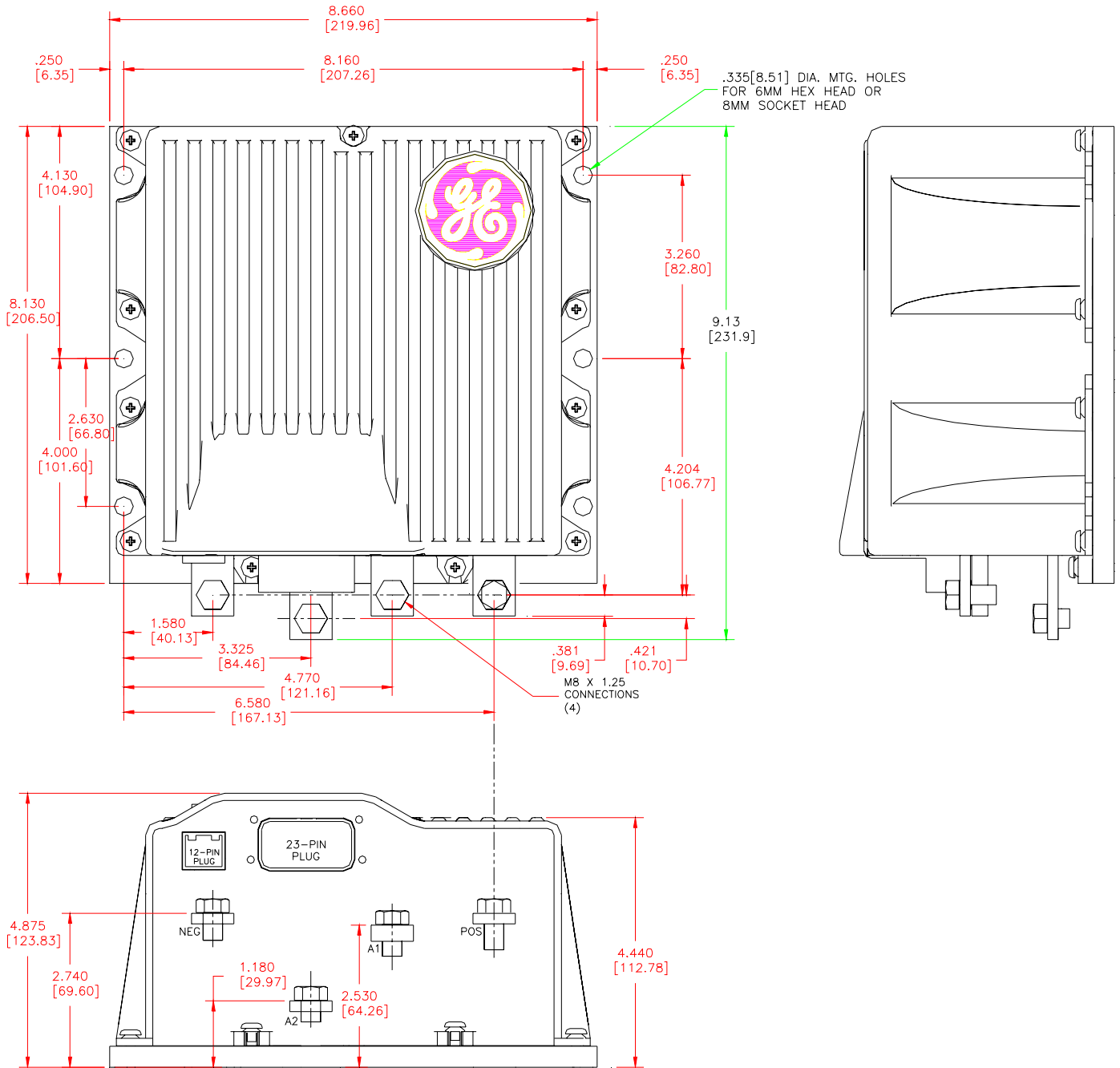

Section 3.3 Outline: SX-3 Package Size

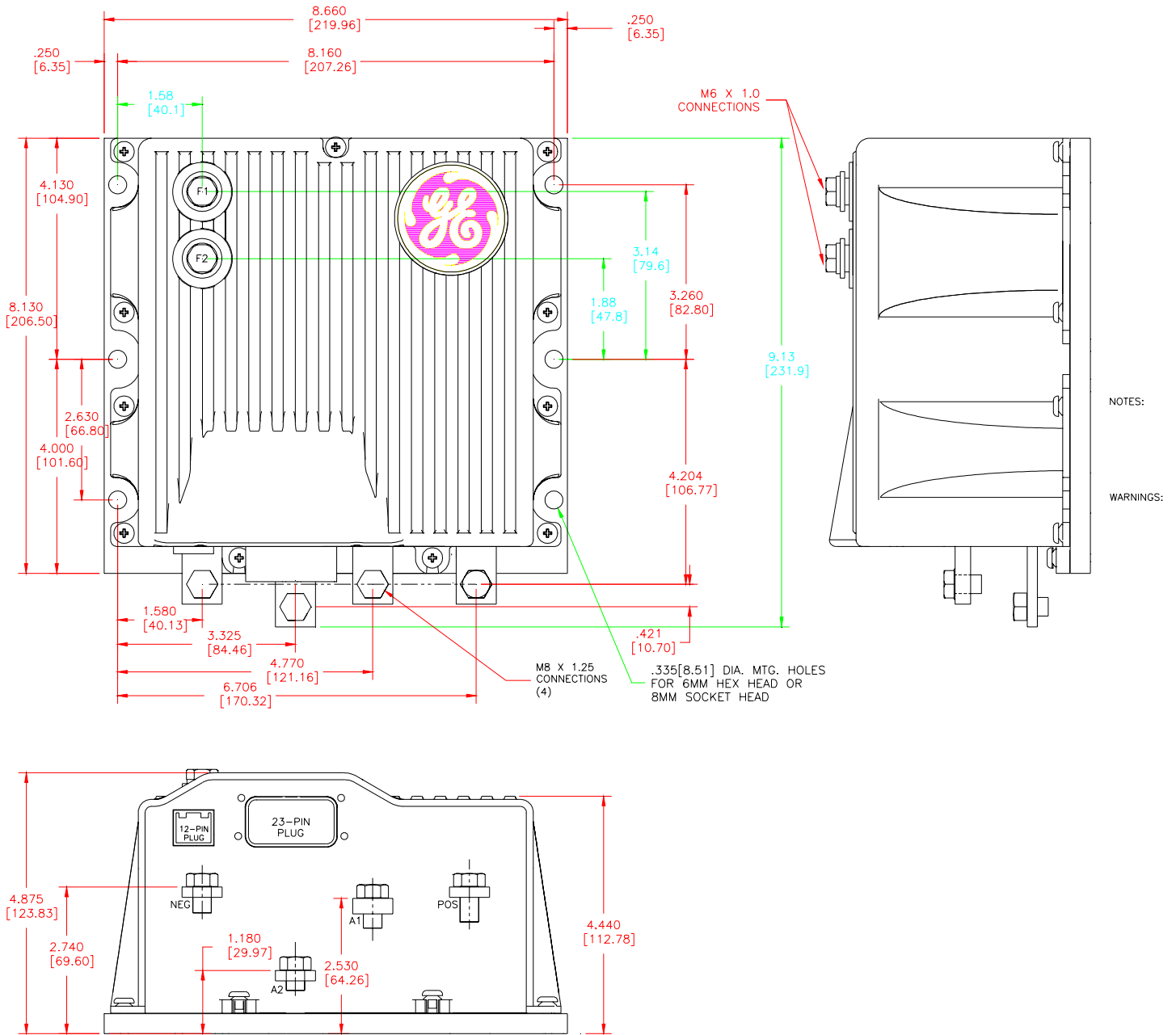

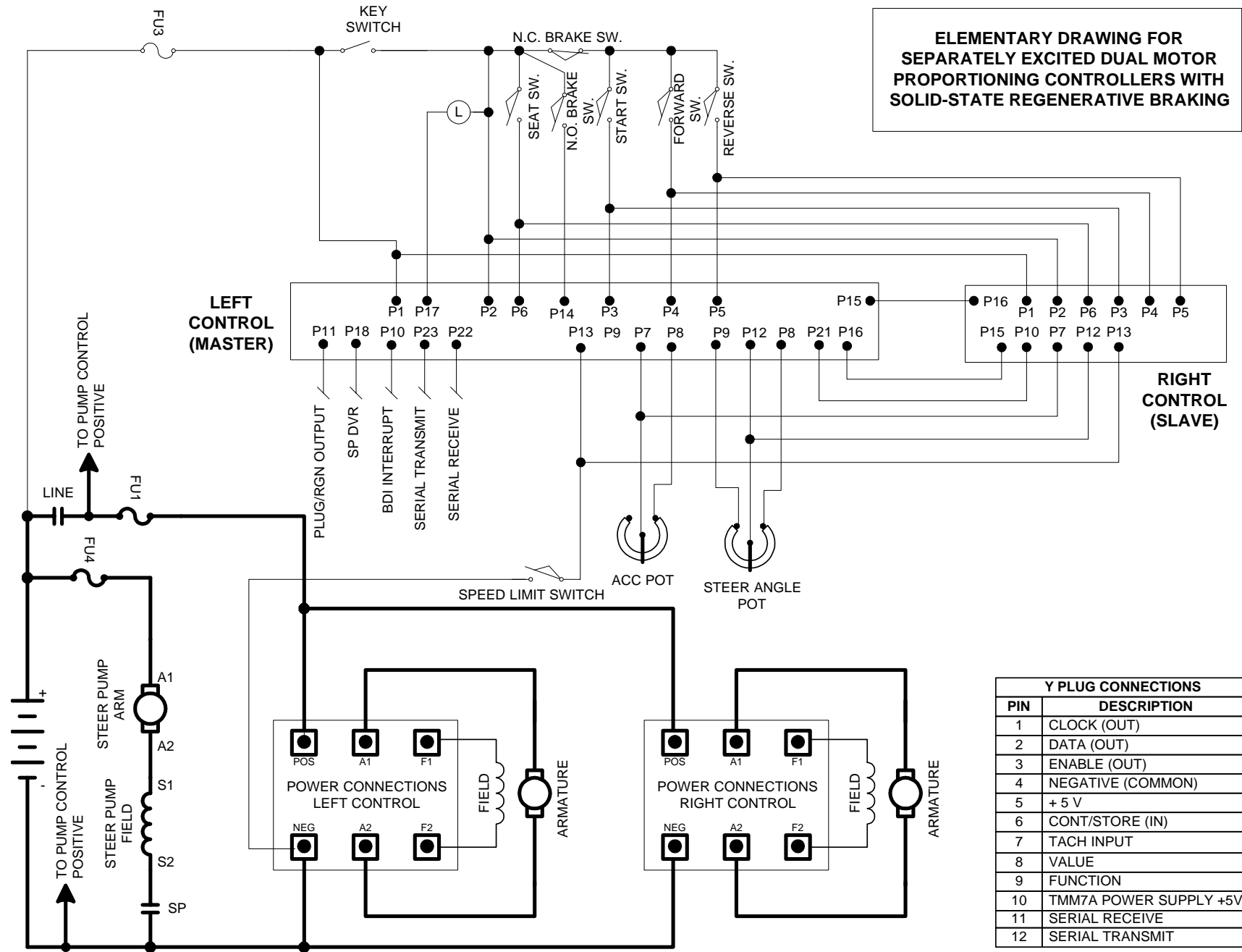

**ELEMENTARY DRAWING FOR SEPARATELY EXCITED DUAL MOTOR PROPORTIONING CONTROLLERS WITH SOLID-STATE REGENERATIVE BRAKING**

Y PLUG CONNECTIONS	
PIN	DESCRIPTION
1	CLOCK (OUT)
2	DATA (OUT)
3	ENABLE (OUT)
4	NEGATIVE (COMMON)
5	+ 5 V
6	CONT/STORE (IN)
7	TACH INPUT
8	VALUE
9	FUNCTION
10	TMM7A POWER SUPPLY +5V
11	SERIAL RECEIVE
12	SERIAL TRANSMIT

Section 3.4 Standard Dual Motor Proportioning Drive Elementary

Section 3:5 Standard Pump Elementary

**ELEMENTARY DRAWING FOR PUMP  
MOTOR CONTROLLER**

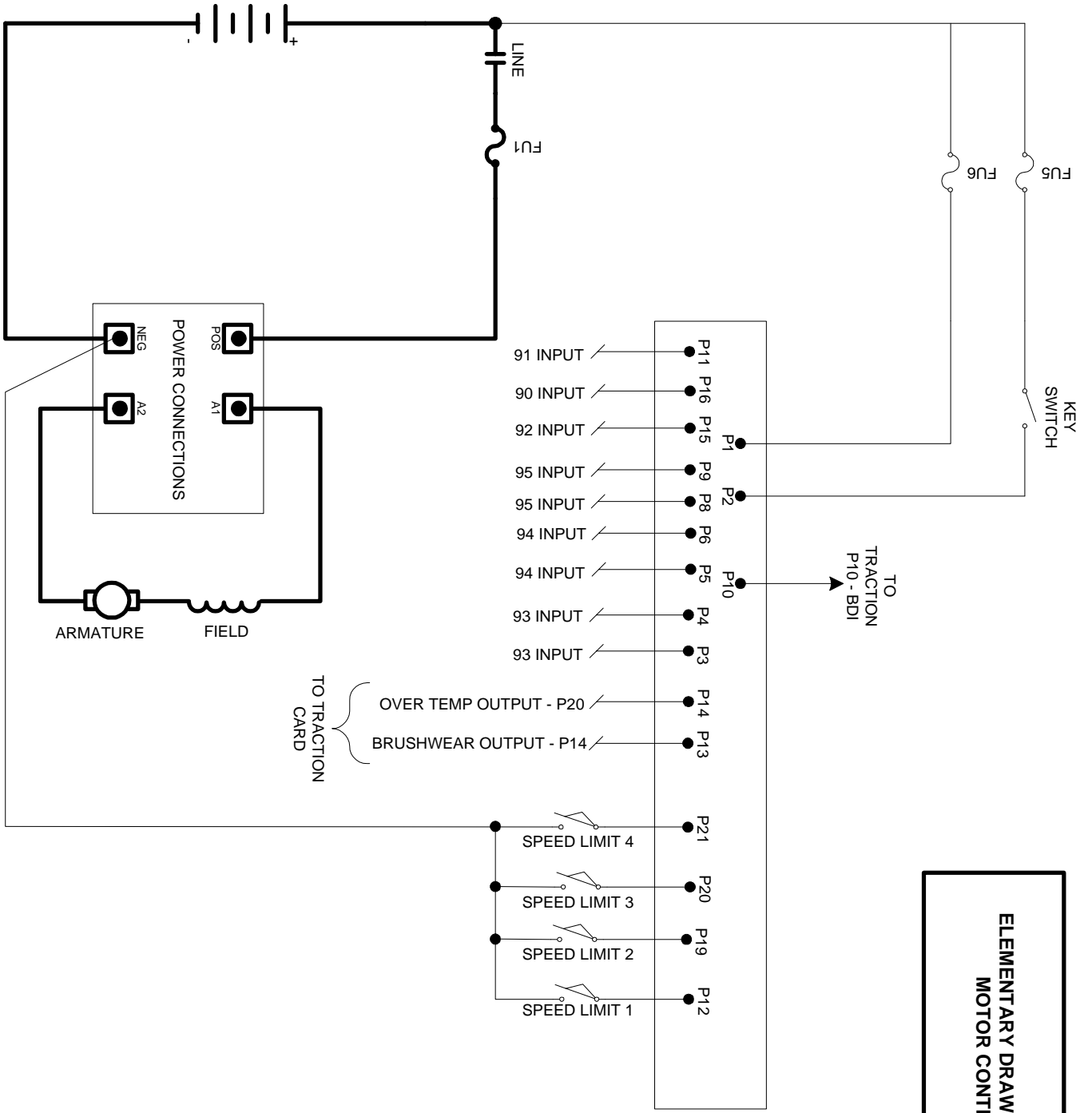

**Section 3.6 Dual Motor Proportioning Drive and Pump Control Input and Output List**  
**CONNECTIONS TO MAIN PLUG (23 PIN) AND "Y" PLUG (12 PIN)**

PIN	STANDARD DUAL MOTOR PROPORTIONING INPUT/OUTPUT DESCRIPTION	STANDARD PUMP INPUT/OUTPUT DESCRIPTION
1	BATTERY VOLTS FROM BATTERY	BATTERY VOLTS FROM BATTERY
2	BATTERY VOLTS FROM KEY	BATTERY VOLTS FROM KEY
3	BATTERY VOLTS FROM START SWITCH	STATUS CODE 93 INPUT
4	BATTERY VOLTS FROM FORWARD SWITCH	STATUS CODE 93 INPUT
5	BATTERY VOLTS FROM REVERSE SWITCH	STATUS CODE 94 INPUT
6	BATTERY VOLTS FROM SEAT SWITCH	STATUS CODE 94 INPUT
7	ACCELERATOR INPUT VOLTAGE SIGNAL	POTENTIOMETER INPUT VOLTAGE SIGNAL
8	ACCELERATOR NEGATIVE	STATUS CODE 95 INPUT
9	ACCELERATOR POT +5 VOLTS SUPPLY & STEER POT	STATUS CODE 95 INPUT
10	BDI INTERRUPT (LEFT) AND PMT ENABLE INPUT (RIGHT)	PUMP ENABLE SIGNAL 12VDC
11	PLUG/RGN OUTPUT SIGNAL +12V 1=PLUG	STATUS CODE 91 INPUT
12	STEER ANGLE INPUT VOLTAGE SIGNAL	SPEED LIMIT #1 INPUT
13	NOT USED	TMM1 BRUSHWEAR INDICATER OUTPUT
14	N.O. BRAKE SW.	TMM1 OVER TEMPERATURE OUTPUT
15	I <sub>MOTOR</sub> OUT	STATUS CODE 92 INPUT
16	MOTOR CURRENT COMPENSATION	STATUS CODE 90 INPUT
17	LINE CONTACTOR DRIVER AND SUPPRESSION	LINE CONTACTOR DRIVER
18	1A OR STEER PUMP CTR DRIVER AND SUPPRESSION	1A CONTACTOR DRIVER
19	STEER ANGLE POT +5 VOLTS SUPPLY	SPEED LIMIT #2 INPUT
20	NOT USED	SPEED LIMIT #3 INPUT
21	PMT ENABLE OUTPUT	SPEED LIMIT #4 INPUT
22	+12V TACH	+12V TACH
23	TACH INPUT	TACH INPUT
PIN	MOTOR PROPORTIONING "Y" PLUG INPUT/OUTPUT DESCRIPTION	PUMP "Y" PLUG INPUT/OUTPUT DESCRIPTION
1	CLOCK (OUT) ( DASH DISPLAY-4)	CLOCK (OUT) ( DASH DISPLAY-4)
2	DATA (OUT) ( DASH DISPLAY-3)	DATA (OUT) ( DASH DISPLAY-3)
3	ENABLE (OUT) ( DASH DISPLAY-1)	ENABLE (OUT) ( DASH DISPLAY-1)
4	NEGATIVE ( DASH DISPLAY-2)	NEGATIVE ( DASH DISPLAY-2)
5	+5V SUPPLY ( DASH DISPLAY-5)	+5V SUPPLY ( DASH DISPLAY-5)
6	CONT/STORE (IN) (HANDSET)	CONT/STORE (IN) (HANDSET)
7	TACH INPUT	TACH INPUT
8	VALUE	VALUE
9	FUNCTION	FUNCTION
10	+12V TACH OUT	+12 TACH OUT
11	SERIAL RECEIVE	SERIAL RECEIVE
12	SERIAL TRANSMIT	SERIAL TRANSMIT

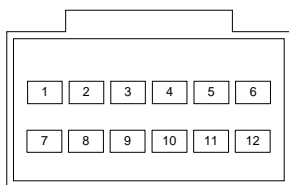

WIRE END VIEW "Y" PLUG

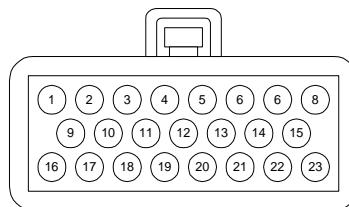

WIRE END VIEW - MAIN PLUG

**NOTE:**

- PY7 is connected internally to P23
- PY10 is connected internally to P22

## Section 4.0 TROUBLESHOOTING AND DIAGNOSTIC STATUS CODES

### Section 4.1 General Maintenance Instructions

The transistor control, like all electrical apparatus, does have some thermal losses. The semiconductor junctions have finite *temperature* limits, above which these devices may be damaged. For these reasons, normal maintenance should guard against any action which will expose the components to excessive heat and/or those conditions which will reduce the heat dissipating ability of the control, such as restricting air flow.

*The following Do's and Don't's should be observed:*

Any controls that will be applied in ambient temperatures over 100° F (40° C) should be brought to the attention of the vehicle manufacturer.

All external components having inductive coils must be filtered. Refer to vehicle manufacturer for specifications.

*The wiring should not be directly steam cleaned.* In dusty areas, blow low-pressure air over the control to remove dust. In oily or greasy areas, a mild solution of detergent or denatured alcohol can be used to wash the control, and then low-pressure air should be used to completely dry the control.

For the control to be most effective, it must be mounted against the frame of the vehicle. The metal vehicle frame, acting as an additional heat sink, will give improved vehicle performance by keeping the control package cooler. *Apply a thin layer of heat-transfer grease (such as Dow Corning 340) between the control heat sink and the vehicle frame.*

Control wire plugs and other exposed transistor control parts should be kept free of dirt and paint that might change the effective resistance between points.

**CAUTION:** *The vehicle should not be plugged when the vehicle is jacked up and the drive wheels are in a free wheeling position. The higher motor speeds can create excessive voltages that can be harmful to the control.*

Do not hipot (or megger) the control. Refer to control manufacturer before hipotting.

Use a lead-acid battery with the voltage and ampere hour rating specified for the vehicle. Follow normal battery maintenance procedures, recharging before 80 percent discharged with periodic equalizing charges.

Visual inspection of GE contactors contained in the traction and pump systems is recommended to occur during every

160 hours of vehicle operation. Inspection is recommended to verify that the contactors are not binding and that the tips are intact and free of contaminants.

GE does not recommend that any type of welding be performed on the vehicle after the installation of the control(s) in the vehicle. GE will not honor control failures during the warranty period when such failures are attributed to welding while the control is installed in the vehicle.

### Section 4.2 Cable Routing and Separation

Electrical noise from cabling of various voltage levels can interfere with a microprocessor-based control system. To reduce this interference, GE recommends specific cable separation and routing practices, consistent with industry standards.

#### Section 4.2.1 Application Responsibility

The customer and customer's representative are responsible for the mechanical and environmental locations of cables. They are also responsible for applying the level rules and cabling practices defined in this section. To help ensure a lower cost, noise-free installation, GE recommends early planning of cable routing that complies with these level separation rules.

On new installations, sufficient space should be allowed to efficiently arrange mechanical and electrical equipment.

On vehicle retrofits, level rules should be considered during the planning stages to help ensure correct application and a more trouble-free installation.

#### Section 4.2.2. Signal/Powerlevel Definitions

The signal/power carrying cables are categorized into four defining levels: low, high, medium power, and high power. Within those levels, signals can be further divided into classes.

Sections 4.2.2.a through 4.2.2.d define these levels and classes, with specific examples of each. Section 4.2.3 contains recommendations for separating the levels.

##### 4.2.2.a Low-Level Signals (Level L)

Low-level signals are designated as *level L*. These consist of:

- Analog signals 0 through  $\pm 15$  V
- Digital signals whose logic levels are less than 15 V DC
- 4 – 20 mA current loops
- DC busses less than 15 V and 250 mA

The following are specific examples of level L signals used in drive equipment cabling:

- Control common tie
- DC buses feeding sensitive analog or digital hardware

- All wiring connected to components associated with sensitive analog hardware with less than 5V signals (for example, potentiometers and tachometers)
- Digital tachometers and resolvers
- Dash display cabling
- RS-232 cabling

**Note:** Signal inputs to analog and digital blocks should be run as shielded twisted-pair (for example, inputs from tachometers, potentiometers, and dash displays).

#### 4.2.2.b High-Level Signals (Level H)

High-level signals are designated as *level H*. These signals consist of:

- Analog and digital signals greater than 15 V DC and less than 250 mA

For example, switch inputs connected to battery volts are examples of level H signals used in drive equipment cabling.

#### 4.2.2.c Medium-Power Signals (Level MP)

Medium power signals are designated as *level MP*. These signals consist of:

- DC switching signals greater than 15 V
- Signals with currents greater than 250 mA and less than 10A

The following are specific examples of level MP signals used in drive equipment cabling:

- DC busses less than 10 A
- Contactor coils less than 10 A
- Machine fields less than 10 A

#### 4.2.2.d. High Power Signals (Level HP)

Power wiring is designated as *level HP*. This consists of DC buses and motor wiring with currents greater than 10 A. The following are specific examples of level HP signals used in drive equipment cabling:

- Motor armature loops
- DC outputs 10 A and above
- Motor field loops 10 A and above

#### 4.2.3. Cable Spacing Guidelines

Recommended spacing (or clearance) between cables (or wires) is dependent on the level of the wiring inside them. For correct level separation when installing cable, the customer must apply the **general guidelines** (section 4.2.3.a), outlined below.

#### 4.2.3.a General Cable Spacing

The following general practices should be used for *all levels* of cabling:

- All cables and wires of like signal levels and power levels must be grouped together.
- In general, different levels must run in separate wire bundles, as defined in the different classes, identified above. Intermixing cannot be allowed, unless noted by exception.
- Interconnecting wire runs should carry a level designation.
- If wires are the same level and same type signal, group those wires from one location to any other location together in multiconductor cables or bind them together with twine or zip-ties.
- When unlike signals must cross, cross them in 90° angles at a maximum spacing. Where it is not possible to maintain spacing, place a grounded steel barrier between unlike levels at the crossover point.

#### 4.2.4 Cabling for Vehicle Retrofits

Reducing electrical noise on vehicle retrofits requires careful planning. Lower and higher levels should never encircle each other or run parallel for long distances. It is practical to use existing wire runs or trays as long as the level spacing (see section 4.2.2) can be maintained for the full length of the run.

Existing cables are generally of high voltage potential and noise producing. Therefore, route levels L and H in a path separate from existing cables, whenever possible.

For level L wiring, use barriers in existing wire runs to minimize noise potential.

Do not loop level L signal wires around level H, level MP, or HP wires.

#### 4.2.5 RF Interference

To prevent radio frequency (RF) interference, care should be taken in routing power cables in the vicinity of radio-controlled devices.

#### Section 4.2.6 Suppression

Unless specifically noted otherwise, suppression (for example, a snubber) is required on all inductive devices controlled by an output. This suppression minimizes noise and prevents damage caused by electrical surges.

#### Section 4.3 Recommended Lubrication of Pins and Sockets Prior to Installation

Beginning in January of 1999, GE will implement the addition of a lubricant to all connections using pins and

sockets on EV100/EV200 and Gen II products. Any connection made by GE to the A, B, X, Y, or Z plugs will have the lubricant NYE 760G added to prevent fretting of these connections during vehicle operation.

Fretting occurs during microscopic movement at the contact points of the connection. This movement exposes the base metal of the connector pin which, when oxygen is present, allows oxidation to occur. Sufficient build up of the oxidation can cause intermittent contact and intermittent vehicle operation. This can occur at any similar type of connection, whether at the control or in any associated vehicle wiring, and the resultant intermittent contact can provide the same fault indication as actual component failure.

The addition of the NYE 760G lubricant will prevent the oxidation process by eliminating the access of oxygen to the contact point. GE recommends the addition of this lubricant to the 12 pin and 23 pin plugs of all new Gen II controls at the time of their installation into a vehicle

When servicing existing vehicles exhibiting symptoms of intermittent mis-operation or shutdown by the GE control, GE recommends the addition of this lubricant to all 12 and 23 pin plugs, after proper cleaning of the connectors, as a preventative measure to insure fretting is not an issue before GE control replacement. Also, for long term reliable control operation, the plug terminals must be maintained per these instructions with the recommended contact cleaner and lubricant which provides a high degree of environmental and fretting protection.

New and re-manufactured control plugs are cleaned and lubricated prior to shipment from the factory. However, in applications where severe vibration or high temperature cycling and excessive humidity ( such as freezers ) are present, it is recommended that the plug terminals be cleaned and lubricated every year, per this instructions. In normal applications, plug maintenance should be performed every two years, unless intermittent problems arise with the plugs, requiring more immediate attention.

**Warning: Do not use any other cleaners or lubricants other than the ones specified.**

**WARNING: Before conducting maintenance on the vehicle, jack up the drive wheels, disconnect the battery and discharge the capacitors. Consult the Operation and Service Manual for your particular vehicle for details on discharging the capacitors; this procedure differs between SCR and Transistor controls.**

1. **Disconnect** plug from controller or mating plug.
2. **Locate** the plug that contains the socket (female) terminals. *Maintenance needs only to be performed on the plug containing the socket (female) type terminals. Reconnecting the plugs will lubricate the pin (male) terminals.*

3. **Clean** each terminal using Chemtronics contact cleaner "Pow-R-WasH CZ " as shown in Figure 1.

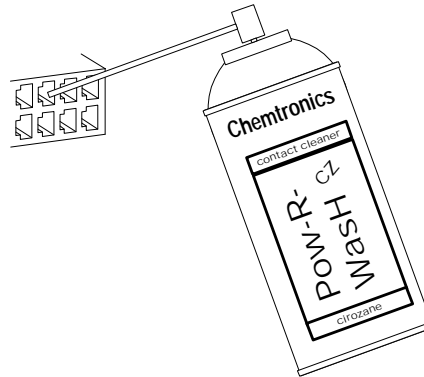

Figure 1

4. **Lubricate** each terminal using Nye 760G lubricant as shown in figure 2. Apply enough lubricant to each terminal opening to completely fill each opening to a depth of .125" minimum.

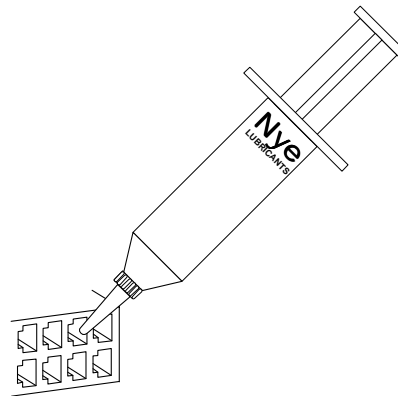

Figure 2

5. **Reconnect** plugs.

Reference

Cleaner	Chemtronics Pow-R-WasH CZ Contact Cleaner
Lubricant	Nye Lubricants NYOGEL 760G
GE Plug Lub Kit	Contains both above products: <b>328AXXXG001</b>

**Section 4.4 General Troubleshooting Instructions**

Trouble-shooting the SX family of controls should be quick and easy when following the instructions outlined in the following status code instruction sheets.

If mis-operation of the vehicle occurs, a status code will be displayed on the Dash Display (for vehicles equipped with a Dash Display) or made available by plugging a Handset into the plug "Y" location, and then reading the status code.

With the status code number, follow the procedures outlined in the status code instruction sheets to determine the problem.

**Important Note:** Due to the interaction of the logic card with all vehicle functions, almost any status code or control fault could be caused by the logic card. After all other status code procedures have been followed and no problem is found, the controller should then be replaced as the last option to correct the problem.

The same device designations have been maintained on different controls but the wire numbers may vary. Refer to the elementary and wiring diagrams for your specific control. The wire numbers shown on the elementary diagram will have identical numbers on the corresponding wiring diagrams for a specific vehicle, but these numbers may be different from the numbers referenced in this publication.

**WARNING: Before trouble-shooting, jack up the drive wheels, disconnect the battery and discharge the capacitors. Reconnect the battery as needed for specific checks. Capacitors should be discharged by connecting a 200 ohm 2 watt resistor between the positive and negative terminals on the control panel.**

Check resistance on R x 1000 scale from frame to power and control terminals. A resistance of less than 20,000 ohms can cause misleading symptoms. Resistance less than 1000 ohms should be corrected first.

Before proceeding, visually check for loose wiring, mis-aligned linkage to the accelerator switch, signs of overheating of components, etc.

Tools and test equipment required are: clip leads, volt-ohm meter (20,000 ohms per volt) and basic hand tools.

Section 4.5 Traction Control Codes

TRACTION STATUS CODE	DESCRIPTION OF STATUS	CAUSE OF STATUS INDICATION
<b>NONE</b>	Segments do not illuminate on the Dash Display and/or the Handset.	No input voltage to the control card or the display unit.
MEMORY RECALL <b>NO</b>	<b>CORRECTIVE ACTIONS</b>	<b><u>TROUBLE-SHOOTING DIAGRAM</u></b>
Circuits valid for Traction Controller	<p><b><u>SYMPTOM</u></b> Display screen on Dash Display and/or Handset is blank.</p> <p><b><u>POSSIBLE CAUSE</u></b> Positive or negative control voltage is not present.</p> <ul style="list-style-type: none"> <li>• Insure that the key switch is closed and voltage is present between P1 &amp; battery negative (Power Terminal "NEG"). Also check for voltage between P2 and control negative.</li> </ul> <p>Open circuit between control card Plug Y &amp; the Dash Display or Handset.</p> <ul style="list-style-type: none"> <li>• Check for an open circuit or loose connection going from the "Y" plug and the Dash Display or Handset.</li> </ul> <p>Defective Dash Display or Handset.</p> <ul style="list-style-type: none"> <li>• Replace Dash Display or Handset.</li> </ul>	

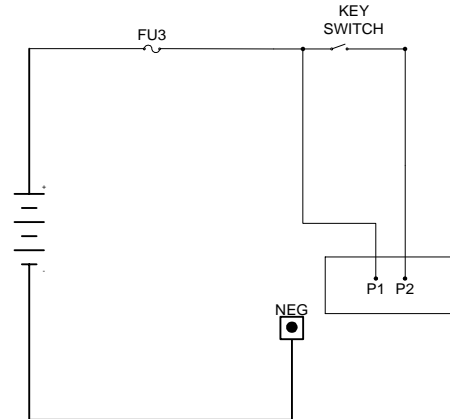

TRACTION STATUS CODE	DESCRIPTION OF STATUS	CAUSE OF STATUS INDICATION
<b>-01</b>	No seat switch or deadman switch input (no voltage to P6).	This status code will be displayed when P6 is less than 50% battery volts.
MEMORY RECALL <b>NO</b>	<b>CORRECTIVE ACTIONS</b>	<b><u>TROUBLE-SHOOTING DIAGRAM</u></b>
Circuits valid for Traction Controller	<p><b><u>SYMPTOM</u></b> Control will not operate.</p> <p><b><u>POSSIBLE CAUSE</u></b> Mis-adjusted or defective seat or deadman switch.</p> <ul style="list-style-type: none"> <li>• Check to see that the seat switch closes properly.</li> </ul> <p>Open circuit between battery positive and P6.</p> <ul style="list-style-type: none"> <li>• Check for loose connections or broken wires: <ul style="list-style-type: none"> <li>- Between the seat switch and P6</li> <li>- Between the key switch and the battery positive side of the seat switch.</li> <li>- Between the seat switch and P2.</li> </ul> </li> <li>• On vehicles without a seat/deadman switch, check for a loose connection or broken wire from P2 and/or P6.</li> </ul>	

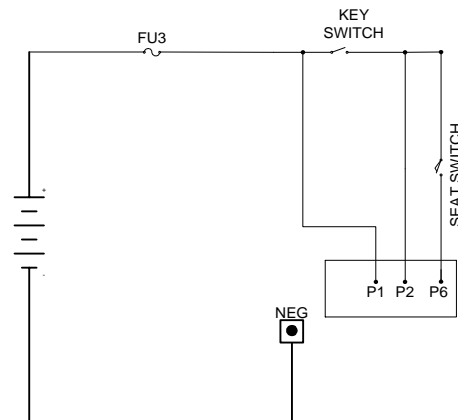

TRACTION STATUS CODE	DESCRIPTION OF STATUS	CAUSE OF STATUS INDICATION
<b>-02</b>	Forward directional switch is closed on initial power up.	This status code will be displayed when P4 is greater than 60% of battery voltage at initial key switch on.
MEMORY RECALL <b>NO</b>	<b>CORRECTIVE ACTIONS</b>	<b><u>TROUBLE-SHOOTING DIAGRAM</u></b>
Circuits valid for Traction Controller	<p><b><u>SYMPTOM</u></b> Control will not operate because of Static Return to Off (SRO) lock out.</p> <p><b><u>POSSIBLE CAUSE</u></b> Forward directional switch is closed on initial start up (i.e. closure of battery, key switch or seat switch).</p> <ul style="list-style-type: none"> <li>Return directional switch lever to neutral and then return lever to forward position.</li> </ul> <p>Forward directional switch is welded closed or mis-adjusted to be held closed.</p> <ul style="list-style-type: none"> <li>Replace or adjust directional switch to insure that it opens when the directional switch is returned to neutral.</li> </ul> <p>Short circuit between P3 and P4.</p> <ul style="list-style-type: none"> <li>Disconnect the wire from P4 and check for a short circuit between P3 and the wire that was connected to P4.</li> </ul> <p>Defective control.</p> <ul style="list-style-type: none"> <li>Replace the controller unit.</li> </ul>	

TRACTION STATUS CODE	DESCRIPTION OF STATUS	CAUSE OF STATUS INDICATION
<b>-03</b>	Reverse directional switch is closed on initial power up.	This status code will be displayed when P5 is greater than 60% of battery voltage at initial key switch on.
MEMORY RECALL <b>NO</b>	<b>CORRECTIVE ACTIONS</b>	<b><u>TROUBLE-SHOOTING DIAGRAM</u></b>
Circuits valid for Traction Controller	<p><b><u>SYMPTOM</u></b> Control will not operate because of Static Return to Off (SRO) lock out.</p> <p><b><u>POSSIBLE CAUSE</u></b> Reverse directional switch is closed on initial start up (i.e. closure of battery, key switch or seat/deadman switch).</p> <ul style="list-style-type: none"> <li>Return directional switch lever to neutral and then return lever to reverse position.</li> </ul> <p>Reverse directional switch is welded closed or mis-adjusted to be held closed.</p> <ul style="list-style-type: none"> <li>Replace or adjust directional switch to insure that it opens when the directional switch is returned to neutral.</li> </ul> <p>Short circuit between P3 and P5.</p> <ul style="list-style-type: none"> <li>Disconnect the wire from P5 and check for a short circuit between P3 and the wire that was connected to P5.</li> </ul> <p>Defective control. Replace the controller unit.</p>	

TRACTION STATUS CODE	DESCRIPTION OF STATUS	CAUSE OF STATUS INDICATION
<b>-05</b>	Start switch or brake switch fails to close.	This status code will be displayed when P7 is less than 2.5 volts and P3 is less than 60% of battery volts.
MEMORY RECALL <b>NO</b>	<b>CORRECTIVE ACTIONS</b>	<b><u>TROUBLE-SHOOTING DIAGRAM</u></b>
Circuits valid for Traction Controller	<p><b><u>SYMPTOM</u></b> Control will not operate.</p> <p><b><u>POSSIBLE CAUSE</u></b> Defective brake switch circuit.</p> <ul style="list-style-type: none"> <li>• Check brake switch to insure closure with brake pedal released.</li> <li>• Check for open circuit or loose connections in wiring from brake switch to seat switch and from P6, and from brake switch to start switch.</li> </ul> <p>Defective start switch circuit.</p> <ul style="list-style-type: none"> <li>• Check start switch to insure closure when accelerator is depressed.</li> <li>• Check for open circuit or loose connections in wiring from brake switch to start switch and from P3 to start switch.</li> </ul> <p>Defective accelerator switch.</p> <ul style="list-style-type: none"> <li>• Check accelerator switch potentiometer for proper operation and ohmic value.</li> </ul>	

TRACTION STATUS CODE	DESCRIPTION OF STATUS	CAUSE OF STATUS INDICATION
<b>-06</b>	Accelerator depressed with no direction selected.	This status code will be displayed when P4 and P5 are less than 60% of battery volts, and P7 is less than 2.5 volts.
MEMORY RECALL <b>NO</b>	<b>CORRECTIVE ACTIONS</b>	<b><u>TROUBLE-SHOOTING DIAGRAM</u></b>
Circuits valid for Traction Controller	<p><b><u>SYMPTOM</u></b> Control will not operate.</p> <p><b><u>POSSIBLE CAUSE</u></b> Accelerator pedal is depressed before closing forward or reverse directional switch.</p> <ul style="list-style-type: none"> <li>• Status code will disappear when directional switch is closed or when accelerator pedal is released.</li> </ul> <p>Defective directional switch</p> <ul style="list-style-type: none"> <li>• Check forward or reverse switch to insure closure when direction is selected.</li> </ul> <p>Open circuit between directional switch(es) and battery positive or between directional switch(es) and P4 or P5.</p> <ul style="list-style-type: none"> <li>• Check all control wires and connections shown in Trouble Shooting Diagram.</li> </ul>	

TRACTION STATUS CODE	DESCRIPTION OF STATUS	CAUSE OF STATUS INDICATION
<b>-07</b>	Accelerator input voltage too high on power up after initial key switch closure.	This status code will be displayed when the accelerator input voltage at P7 is higher than 3.7 volts, and a directional contactor is picked up.
MEMORY RECALL <b>NO</b>	<b>CORRECTIVE ACTIONS</b>	<b><u>TROUBLE-SHOOTING DIAGRAM</u></b>
Circuits valid for Traction Controller	<p><b><u>SYMPTOM</u></b> Control will not operate when accelerator pedal is depressed or status code -07 is displayed then disappears when the vehicle starts to accelerate.</p> <p><b><u>POSSIBLE CAUSE</u></b> Accelerator input mis-adjusted or defective.</p> <ul style="list-style-type: none"> <li>Input voltage at P7 should be less than 3.7 volts. Adjust or replace accelerator unit to insure that the voltage at P7 will vary from 3.5 volts to less than .5 volts when the pedal is depressed.</li> </ul> <p>Open circuit between battery negative and P7 in accelerator input circuit.</p> <ul style="list-style-type: none"> <li>Check for broken wires or loose connections or open potentiometer / voltage supply.</li> </ul> <p>Short circuit from battery positive to wiring in accelerator input circuit.</p> <ul style="list-style-type: none"> <li>Disconnect wire from P7 and measure voltage at wire to negative. Should be zero volts for potentiometer type and less than 3.7 volts for solid state type accelerator input.</li> </ul>	

TRACTION STATUS CODE	DESCRIPTION OF STATUS	CAUSE OF STATUS INDICATION
<b>-08</b>	Accelerator input voltage too low on power up after initial key switch closure.	This status code will be displayed when the accelerator input voltage at P7 is less than 3.0 volts, and any of the following connections are opened and closed: battery plug or key switch.
MEMORY RECALL <b>NO</b>	<b>CORRECTIVE ACTIONS</b>	<b><u>TROUBLE-SHOOTING DIAGRAM</u></b>
Circuits valid for Traction Controller	<p><b><u>SYMPTOM</u></b> Control will not operate.</p> <p><b><u>POSSIBLE CAUSE</u></b> Accelerator input mis-adjusted or defective.</p> <ul style="list-style-type: none"> <li>Input voltage at P7 should be more than 3.0 volts. Adjust or replace accelerator unit to insure that the voltage at P7 is more than 3.0 volts before depressing pedal.</li> </ul> <p>Short circuit between battery negative and TB1 in accelerator input circuit.</p> <ul style="list-style-type: none"> <li>Disconnect wire from P7. Check for short circuit from wire to battery negative. Resistance should be greater than 4.7K ohms.</li> </ul> <p>Defective Card</p> <ul style="list-style-type: none"> <li>Disconnect wire from P7. Measure voltage from TB1 to negative. Voltage should be greater than 4.5 volts, if not, replace control.</li> </ul>	

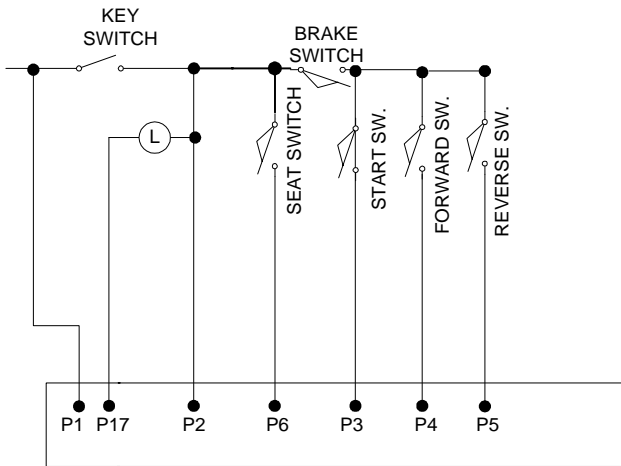
TRACTION STATUS CODE	DESCRIPTION OF STATUS	CAUSE OF STATUS INDICATION
<b>-09</b>	Both the forward and reverse directional switches are closed at the same time.	This status code will be displayed when P4 and P5 are greater than 60% of battery volts at the same time.
MEMORY RECALL <b>NO</b>	<b>CORRECTIVE ACTIONS</b>	<b><u>TROUBLE-SHOOTING DIAGRAM</u></b>
Circuits valid for Traction Controller	<p><b><u>SYMPTOM</u></b> Control will not operate.</p> <p><b><u>POSSIBLE CAUSE</u></b> Forward or reverse directional switch welded closed or mis-adjusted to be held closed.</p> <ul style="list-style-type: none"> <li>• Replace or adjust directional switches to insure that they open when directional switch is returned to neutral.</li> </ul> <p>Short circuit between battery positive and P4 and/or P5.</p> <ul style="list-style-type: none"> <li>• Disconnect wires from P4 and P5 and check wire for short circuit to positive side of directional switch.</li> </ul> <p>Defective Control</p> <ul style="list-style-type: none"> <li>• Disconnect wires and measure voltage at P4 and P5. Voltage should be less than 60% of battery volts.</li> </ul>	

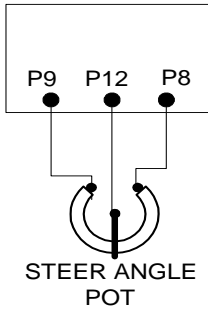
TRACTION STATUS CODE	DESCRIPTION OF STATUS	CAUSE OF STATUS INDICATION
<b>-10</b>	Steer angle potentiometer voltage is too high.	This status code will be displayed when P12 is greater than 3.9 volts.
MEMORY RECALL <b>NO</b>	<b>CORRECTIVE ACTIONS</b>	<b><u>TROUBLE-SHOOTING DIAGRAM</u></b>
Circuits valid for Traction Controller	<p><b><u>SYMPTOM</u></b> Control will not operate.</p> <p><b><u>POSSIBLE CAUSE</u></b> Steer angle potentiometer input mis-adjusted or defective. Loose or missing connections at P19, P12 or P20.</p> <ul style="list-style-type: none"> <li>• Input voltage at P12 should be less than 3.9 volts at all times. Insure that the adjustment of the steer potentiometer is in accordance with Section 9 of this instruction.</li> </ul> <p>Defective control.</p> <ul style="list-style-type: none"> <li>• Replace control unit.</li> </ul>	

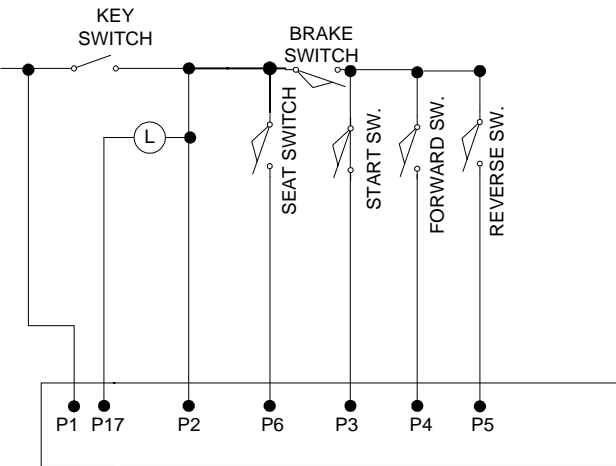
TRACTION STATUS CODE	DESCRIPTION OF STATUS	CAUSE OF STATUS INDICATION
<b>-11</b>	Start switch closed on power up after initial key switch closure.	This status code will be displayed when P3 is greater than 60% of battery voltage when the key switch is closed.
MEMORY RECALL <b>NO</b>	<b>CORRECTIVE ACTIONS</b>	<b><u>TROUBLE-SHOOTING DIAGRAM</u></b>
Circuits valid for Traction Controller	<p><b><u>SYMPTOM</u></b> Control will not operate.</p> <p><b><u>POSSIBLE CAUSE</u></b> Start switch input mis-adjusted or defective.</p> <ul style="list-style-type: none"> <li>Input voltage at P3 should be less than 60% of battery volts at key switch closing. Adjust or replace accelerator unit to insure that the voltage at P3 is less than 60% of battery volts before closing the start switch.</li> </ul> <p>Short circuit between battery positive and P3 in start switch input circuit.</p> <ul style="list-style-type: none"> <li>Disconnect wire from P3. Check for short circuit from this wire to battery positive. Resistance should be greater than 4.7K ohms.</li> </ul> <p>Defective control.</p> <ul style="list-style-type: none"> <li>Disconnect wire from P3. Measure voltage from P3 to negative. Voltage should be zero, if not, replace control.</li> </ul>	

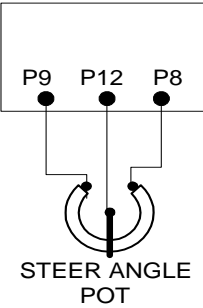
TRACTION STATUS CODE	DESCRIPTION OF STATUS	CAUSE OF STATUS INDICATION
<b>-12</b>	Steer angle potentiometer voltage is too low.	This status code will be displayed when P12 is less than .39 volts.
MEMORY RECALL <b>NO</b>	<b>CORRECTIVE ACTIONS</b>	<b><u>TROUBLE-SHOOTING DIAGRAM</u></b>
Circuits valid for Traction Controller	<p><b><u>SYMPTOM</u></b> Control will not operate.</p> <p><b><u>POSSIBLE CAUSE</u></b> Steer angle potentiometer input mis-adjusted or defective. Loose or missing connections at P19, P12 or P20.</p> <ul style="list-style-type: none"> <li>Input voltage at P12 should be greater than .39 volts at all times. Insure that the adjustment of the steer potentiometer is in accordance with Section 9 of this instruction.</li> </ul> <p>Defective control.</p> <ul style="list-style-type: none"> <li>Replace control unit.</li> </ul>	

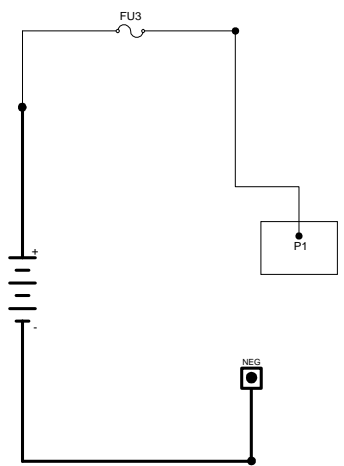
TRACTION STATUS CODE	DESCRIPTION OF STATUS	CAUSE OF STATUS INDICATION												
<b>-15</b>	Battery voltage is too low or control card is mis-adjusted.	This status code will be displayed when the battery volts are less than 1.95 volts per cell at initial key switch on. See table below.												
MEMORY RECALL <b>NO</b>	<b>CORRECTIVE ACTIONS</b>	<b>TROUBLE-SHOOTING DIAGRAM</b>												
Circuits valid for Traction Controller	<p><b>SYMPTOM</b> Control will not operate.</p> <p><b>POSSIBLE CAUSE</b> Discharged battery</p> <ul style="list-style-type: none"> <li>Check battery for proper open circuit voltage as shown in "Trouble Shooting Diagram", charge battery, if required.</li> </ul> <p>Defective battery</p> <ul style="list-style-type: none"> <li>Check each battery cell for proper voltage (greater than 1.95 volts at cell). Replace or repair battery.</li> </ul> <p>Incorrect control card adjustment.</p> <ul style="list-style-type: none"> <li>Check Function 15 for proper adjustment for battery being used. See Handset instruction sheet for details. Adjust to proper settings.</li> </ul> <p>Check "minimum" battery volts at P1 and NEG.</p>	 <table border="1" data-bbox="1242 493 1469 724"> <thead> <tr> <th>NOMINAL BATTERY VOLTAGE</th> <th>MINIMUM LIMIT VOLTS AT 1.95 VDC PER CELL</th> </tr> </thead> <tbody> <tr> <td>24</td> <td>23.4</td> </tr> <tr> <td>36</td> <td>35.1</td> </tr> <tr> <td>48</td> <td>46.8</td> </tr> <tr> <td>72</td> <td>70.2</td> </tr> <tr> <td>80</td> <td>78.0</td> </tr> </tbody> </table>	NOMINAL BATTERY VOLTAGE	MINIMUM LIMIT VOLTS AT 1.95 VDC PER CELL	24	23.4	36	35.1	48	46.8	72	70.2	80	78.0
NOMINAL BATTERY VOLTAGE	MINIMUM LIMIT VOLTS AT 1.95 VDC PER CELL													
24	23.4													
36	35.1													
48	46.8													
72	70.2													
80	78.0													

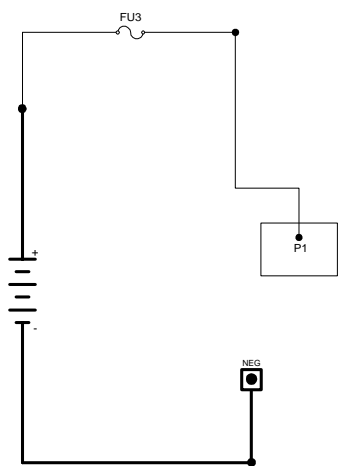
TRACTION STATUS CODE	DESCRIPTION OF STATUS	CAUSE OF STATUS INDICATION												
<b>-16</b>	Battery voltage is too high or control card is mis-adjusted.	This status code will be displayed when the battery volts are greater than 2.4 volts per cell at initial key switch on. See table below.												
MEMORY RECALL <b>NO</b>	<b>CORRECTIVE ACTIONS</b>	<b>TROUBLE-SHOOTING DIAGRAM</b>												
Circuits valid for Traction Controller	<p><b>SYMPTOM</b> Control will not operate.</p> <p><b>POSSIBLE CAUSE</b> Incorrect control card adjustment Check Function 15 for proper adjustment for battery being used. See Handset instructions for details. Adjust to proper setting.</p> <p>Battery over charged or incorrect battery used.</p> <ul style="list-style-type: none"> <li>Check battery for proper open circuit voltage per table at right. If voltage is excessive, check battery charger for proper output voltage.</li> </ul> <p>Check "maximum" battery volts at P1 and NEG.</p>	 <table border="1" data-bbox="1242 1323 1469 1554"> <thead> <tr> <th>NOMINAL BATTERY VOLTAGE</th> <th>MAXIMUM LIMIT VOLTS AT 2.40 VDC PER CELL</th> </tr> </thead> <tbody> <tr> <td>24</td> <td>28.8</td> </tr> <tr> <td>36</td> <td>43.2</td> </tr> <tr> <td>48</td> <td>57.6</td> </tr> <tr> <td>72</td> <td>86.4</td> </tr> <tr> <td>80</td> <td>96.0</td> </tr> </tbody> </table>	NOMINAL BATTERY VOLTAGE	MAXIMUM LIMIT VOLTS AT 2.40 VDC PER CELL	24	28.8	36	43.2	48	57.6	72	86.4	80	96.0
NOMINAL BATTERY VOLTAGE	MAXIMUM LIMIT VOLTS AT 2.40 VDC PER CELL													
24	28.8													
36	43.2													
48	57.6													
72	86.4													
80	96.0													

TRACTION STATUS CODE	DESCRIPTION OF STATUS	CAUSE OF STATUS INDICATION
<b>-17</b>	"Control Type" selection is invalid.	This status code will be displayed when the control type selection value is set to an invalid number.
MEMORY RECALL <b>NO</b>	<b>CORRECTIVE ACTIONS</b>	<b><u>TROUBLE-SHOOTING DIAGRAM</u></b>
Circuits valid for Traction Controller	<p><b><u>SYMPTOM</u></b> Control will not operate.</p> <p><b><u>POSSIBLE CAUSE</u></b> Invalid card type selection. Review Function 17 in the Handset Instruction sheets. Adjust and set card type value as instructed by OEM service manual.</p>	<p><b>NO GRAPHIC</b></p> <p><b>FOR THIS STATUS CODE</b></p>

TRACTION STATUS CODE	DESCRIPTION OF STATUS	CAUSE OF STATUS INDICATION
<b>-23</b>	Motor field current is high on start up in the reverse direction.	This status code will be displayed when the current draw in the motor field is too high at start up in the reverse direction.
MEMORY RECALL <b>NO</b>	<b>CORRECTIVE ACTIONS</b>	<b><u>TROUBLE-SHOOTING DIAGRAM</u></b>
Circuits valid for Traction Controller	<p><b><u>SYMPTOM</u></b> Control will not operate.</p> <p><b><u>POSSIBLE CAUSE</u></b> Defective control. • Replace controller unit.</p>	<p>The diagram illustrates the electrical circuit for the motor field. It starts with a power source (battery symbol) connected to a fuse FU1 and a line. The circuit passes through a KEY SWITCH and a BRAKE SW. before reaching a PLUG PL2. The PLUG PL2 has terminals P1, P17, P2, P6, P8, P3, P7, P4, P9, and P5. The SEAT SW., START SW., FORWARD SW., and REVERSE SW. are connected to these terminals. The circuit then goes through an ACC POT and finally to the motor's FIELD and ARMATURE. The motor's power connections are labeled POS, NEG, A1, A2, F1, and F2.</p>

TRACTION STATUS CODE	DESCRIPTION OF STATUS	CAUSE OF STATUS INDICATION
<b>-24</b>	Motor field current is high on start up in the forward direction.	This status code will be displayed when the current draw in the motor field is too high at start up in the forward direction.
MEMORY RECALL <b>NO</b>	<b>CORRECTIVE ACTIONS</b>	<b>TROUBLE-SHOOTING DIAGRAM</b>
Circuits valid for Traction Controller	<p><b>SYMPTOM</b> Control will not operate.</p> <p><b>POSSIBLE CAUSE</b> Defective control.</p> <ul style="list-style-type: none"> <li>• Replace controller unit.</li> </ul>	

TRACTION STATUS CODE	DESCRIPTION OF STATUS	CAUSE OF STATUS INDICATION
<b>-27</b>	Power supply is less than 10 Volts DC.	This status code will be displayed when the power supply is less than 10 volts.
MEMORY RECALL <b>YES</b>	<b>CORRECTIVE ACTIONS</b>	<b>TROUBLE-SHOOTING DIAGRAM</b>
Circuits valid for Traction Controller	<p><b>SYMPTOM</b> Line contactor opens and closes, then can only be closed by opening and closing the key switch.</p> <p><b>POSSIBLE CAUSE</b> Discharged Battery</p> <ul style="list-style-type: none"> <li>• Check battery to insure proper state of charge. Voltage may be dropping below 10 Volts DC under load.</li> </ul> <p>Loose connection at P1.</p> <ul style="list-style-type: none"> <li>• Insure that the wire connection at P1 is tight.</li> </ul> <p>Defective control.</p> <ul style="list-style-type: none"> <li>• Replace controller unit.</li> </ul>	

TRACTION STATUS CODE	DESCRIPTION OF STATUS	CAUSE OF STATUS INDICATION
<b>-28</b>	Motor field current is too high during the run mode.	This status code will be displayed when the current in the motor field is sustained above a preset limit for longer than 35 or 70 seconds, depending on control type.
MEMORY RECALL <b>YES</b>	<b>CORRECTIVE ACTIONS</b>	<b><u>TROUBLE-SHOOTING DIAGRAM</u></b>
Circuits valid for Traction Controller	<p><b><u>SYMPTOM</u></b> Control will not operate.</p> <p><b><u>POSSIBLE CAUSE</u></b> Continued operation of vehicle in high motor current condition.</p> <ul style="list-style-type: none"> <li>Operate vehicle at lower motor current condition for 35 or 70 seconds, depending on control type.</li> </ul> <p>Function 7 is mis-adjusted to allow higher than normal motor field current.</p> <ul style="list-style-type: none"> <li>Adjust function per OEM instructions.</li> </ul>	<h1>NO GRAPHIC FOR THIS STATUS CODE</h1>

TRACTION STATUS CODE	DESCRIPTION OF STATUS	CAUSE OF STATUS INDICATION
<b>-29</b>	Motor armature current is too high during the run mode. ( Dual Motor Proportioning Controls Only)	This status code will be displayed when the motor current in control "A" is greater than 125A while the motor current in control "B" is less than 26A for a 16 second interval.
MEMORY RECALL <b>YES</b>	<b>CORRECTIVE ACTIONS</b>	<b><u>TROUBLE-SHOOTING DIAGRAM</u></b>
Circuits valid for Traction Controller	<p><b><u>SYMPTOM</u></b> Control operates at the reduced speed set by Speed Limit 3.</p> <p><b><u>POSSIBLE CAUSE</u></b> Continued operation of vehicle in high motor current condition.</p> <ul style="list-style-type: none"> <li>Verify operation of other control during the run mode.</li> <li>Examine opposite control for stored faults which may have shut down the opposite control.</li> <li>Verify the connection between P16 of the master and P17 of the auxiliary control</li> </ul>	

TRACTION STATUS CODE	DESCRIPTION OF STATUS	CAUSE OF STATUS INDICATION
<b>-30</b>	PMT enable signal from auxiliary control to master at PL21 is missing during SRO check. ( Dual Motor Proportioning Controls Only)	This status code will be displayed when the voltage at PL21 of the master control is less than 5 volts. This fault is not stored.
MEMORY RECALL <b>NO</b>	<b>CORRECTIVE ACTIONS</b>	<b><u>TROUBLE-SHOOTING DIAGRAM</u></b>
Circuits valid for Traction Controller	<p><b><u>SYMPTOM</u></b> Auxiliary control shut down</p> <p><b><u>POSSIBLE CAUSE</u></b></p> <ul style="list-style-type: none"> <li>• Check auxiliary control for status codes.</li> <li>• Verify connection between PL21 of master control and PL10 of slave/auxiliary control.</li> </ul>	

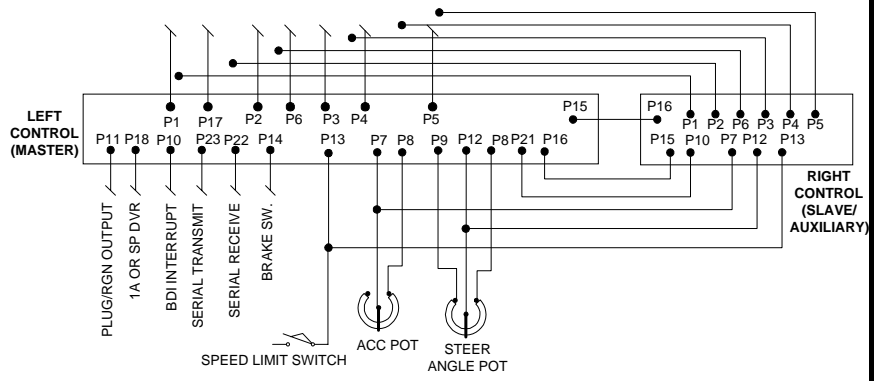

TRACTION STATUS CODE	DESCRIPTION OF STATUS	CAUSE OF STATUS INDICATION
<b>-41</b>	Open thermal protector (TP) or transistor over temperature.	This status code will be displayed when the voltage at the thermal protector is too high.
MEMORY RECALL <b>YES</b>	<b>CORRECTIVE ACTIONS</b>	<b><u>TROUBLE-SHOOTING DIAGRAM</u></b>
Circuits valid for Traction Controller	<p><b><u>SYMPTOM</u></b> Reduced or no power to traction motor in control range.</p> <p><b><u>POSSIBLE CAUSE</u></b> Control is in thermal cut-back.</p> <ul style="list-style-type: none"> <li>• Allow control to cool, status code should disappear.</li> </ul> <p>Defective control.</p> <ul style="list-style-type: none"> <li>• Replace controller unit.</li> </ul>	

**NO GRAPHIC FOR THIS STATUS CODE**

TRACTION STATUS CODE	DESCRIPTION OF STATUS	CAUSE OF STATUS INDICATION
<b>-42</b>	Motor armature offset voltage is too high.	This status code will be displayed when the voltage at the current sensor input is greater than 2.6 volts with no current flowing in the motor circuit.
MEMORY RECALL <b>NO</b>	<b>CORRECTIVE ACTIONS</b>	<b><u>TROUBLE-SHOOTING DIAGRAM</u></b>
Circuits valid for Traction Controller	<p><b><u>SYMPTOM</u></b> Control will not operate.</p> <p><b><u>POSSIBLE CAUSE</u></b> Defective control.</p> <ul style="list-style-type: none"> <li>• Replace controller unit.</li> </ul>	<b>NO GRAPHIC FOR THIS STATUS CODE</b>

TRACTION STATUS CODE	DESCRIPTION OF STATUS	CAUSE OF STATUS INDICATION
<b>-43</b>	Motor armature offset voltage is too low.	This status code will be displayed when the voltage at the current sensor input is less than 2.4 volts with no current flowing in the motor circuit.
MEMORY RECALL <b>NO</b>	<b>CORRECTIVE ACTIONS</b>	<b><u>TROUBLE-SHOOTING DIAGRAM</u></b>
Circuits valid for Traction Controller	<p><b><u>SYMPTOM</u></b> Control will not operate.</p> <p><b><u>POSSIBLE CAUSE</u></b> Defective control.</p> <ul style="list-style-type: none"> <li>• Replace controller unit.</li> </ul>	<b>NO GRAPHIC FOR THIS STATUS CODE</b>

TRACTION STATUS CODE	DESCRIPTION OF STATUS	CAUSE OF STATUS INDICATION
<b>-44</b>	Armature transistor did not turn off properly.	This status code will be displayed when, during control operation, the armature transistor fails to turn off. This will result in a PMT condition.
MEMORY RECALL <b>YES</b>	<b>TROUBLE-SHOOTING DIAGRAM</b>	
Circuits valid for Traction Controller	<p><b>SYMPTOM</b> Line contactor opens and closes, then can only be closed by opening and closing the key switch.</p> <p><b>POSSIBLE CAUSE</b> Defective control.</p> <ul style="list-style-type: none"> <li>• Replace controller unit.</li> </ul>	

TRACTION STATUS CODE	DESCRIPTION OF STATUS	CAUSE OF STATUS INDICATION
<b>-45</b>	Armature transistor did not turn on properly.	This status code will be displayed when, during control operation, the armature transistor fails to turn on properly. This will result in a PMT condition.
MEMORY RECALL <b>YES</b>	<b>TROUBLE-SHOOTING DIAGRAM</b>	
Circuits valid for Traction Controller	<p><b>SYMPTOM</b> Line contactor open and closes, then can only be closed by opening and closing the key switch.</p> <p><b>POSSIBLE CAUSE</b> Defective control.</p> <ul style="list-style-type: none"> <li>• Replace controller unit.</li> </ul>	

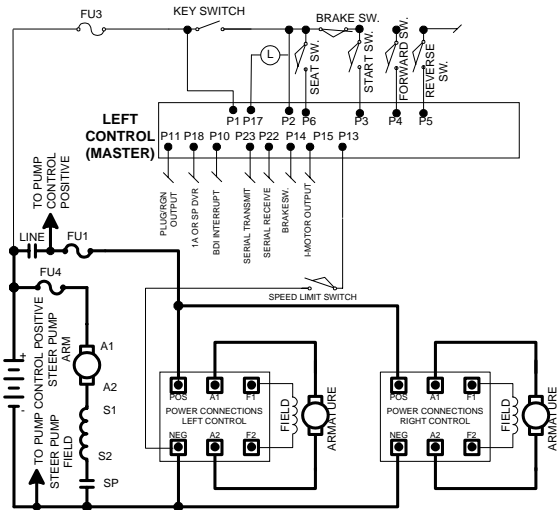
TRACTION STATUS CODE	DESCRIPTION OF STATUS	CAUSE OF STATUS INDICATION
<b>-46</b>	"Look Ahead" test for A2 volts less than 12% of battery volts.	This status code will be displayed when the voltage at A2 is less than 12% of battery volts.
MEMORY RECALL <b>NO</b>	<b>CORRECTIVE ACTIONS</b>	<b><u>TROUBLE-SHOOTING DIAGRAM</u></b>
Circuits valid for Traction Controller	<p><b><u>SYMPTOM</u></b> Line contactor will not pick up.</p> <p><b><u>POSSIBLE CAUSE</u></b> Check for short circuit from the motor armature to the frame of the vehicle.</p> <p>Defective control.</p> <ul style="list-style-type: none"> <li>• Replace controller unit.</li> </ul>	 <p>The diagram illustrates the electrical circuit for the traction controller. It shows the power flow from the battery through fuses FU1, FU2, FU3, and FU4. Key components include the KEY SWITCH, BRAKE SW., BEAT SW., START SW., FORWARD SW., and REVERSE SW. The circuit is divided into LEFT CONTROL (MASTER) and RIGHT CONTROL sections. The LEFT CONTROL section includes terminals P11, P17, P10, P23, P22, P14, P15, and P13, connected to various outputs like PUMP OUTPUT, 1A OR SP DIR, BDI INTERRUPT, SERIAL TRANSMIT, SERIAL RECEIVE, BRAKESW, and MOTOR OUTPUT. The RIGHT CONTROL section includes terminals POS, AT, and FT, connected to the FIELD and ARMATURE of the motor. The diagram also shows the connection to the motor armature and the SPEED LIMIT SWITCH.</p>

TRACTION STATUS CODE	DESCRIPTION OF STATUS	CAUSE OF STATUS INDICATION
<b>-49</b>	Motor field current is too low during the run mode.	This status code will be displayed when the current draw in the motor field is too low during the run mode.
MEMORY RECALL <b>NO</b>	<b>CORRECTIVE ACTIONS</b>	<b><u>TROUBLE-SHOOTING DIAGRAM</u></b>
Circuits valid for Traction Controller	<p><b><u>SYMPTOM</u></b> Control will not operate.</p> <p><b><u>POSSIBLE CAUSE</u></b> Defective control.</p> <ul style="list-style-type: none"> <li>• Replace controller unit.</li> </ul>	<p><b>NO GRAPHIC FOR THIS STATUS CODE</b></p>

TRACTION STATUS CODE	DESCRIPTION OF STATUS	CAUSE OF STATUS INDICATION
<b>-51</b>	Capacitor volts are low before the line contactor closes.	This status code will be displayed during "key on" when the capacitor volts is less than 85% of battery volts at initial key switch on.
MEMORY RECALL <b>NO</b>	<b>CORRECTIVE ACTIONS</b>	<b>TROUBLE-SHOOTING DIAGRAM</b>
Circuits valid for Traction Controller	<p><b>SYMPTOM</b> Line contactor does not close when capacitor does not precharge.</p> <p><b>POSSIBLE CAUSE</b> Defective control fuse.</p> <ul style="list-style-type: none"> <li>• Check control fuse for open circuit. Replace fuse, if necessary.</li> </ul> <p>Defective control.</p> <ul style="list-style-type: none"> <li>• Replace controller unit.</li> </ul>	

TRACTION STATUS CODE	DESCRIPTION OF STATUS	CAUSE OF STATUS INDICATION
<b>-52</b>	Line contactor driver shorted on start up.	This status code will be displayed when the control detects a shorted line contactor driver during start up.
MEMORY RECALL <b>NO</b>	<b>CORRECTIVE ACTIONS</b>	<b>TROUBLE-SHOOTING DIAGRAM</b>
Circuits valid for Traction Controller	<p><b>SYMPTOM</b> Control will not operate.</p> <p><b>POSSIBLE CAUSE</b> Defective control.</p> <ul style="list-style-type: none"> <li>• Replace controller unit.</li> </ul>	<p style="text-align: center;"><b>NO GRAPHIC FOR THIS STATUS CODE</b></p>

TRACTION STATUS CODE	DESCRIPTION OF STATUS	CAUSE OF STATUS INDICATION
<b>-57</b>	Controller "motor current sensor" input too low during running.	This status code will be displayed when the voltage input from the current sensor is too low during running.
MEMORY RECALL <b>YES</b>	<b>CORRECTIVE ACTIONS</b>	<b><u>TROUBLE-SHOOTING DIAGRAM</u></b>
Circuits valid for Traction Controller	<p><b><u>SYMPTOM</u></b> Control will not operate.</p> <p><b><u>POSSIBLE CAUSE</u></b> Defective control.</p> <ul style="list-style-type: none"> <li>• Replace controller unit.</li> </ul>	<p><b>NO GRAPHIC FOR THIS STATUS CODE</b></p>

TRACTION STATUS CODE	DESCRIPTION OF STATUS	CAUSE OF STATUS INDICATION
<b>-66</b>	FET field protection has shut down.	This status code will be displayed when field transistor drops high. The control is reset by recycling the key switch.
MEMORY RECALL <b>YES</b>	<b>CORRECTIVE ACTIONS</b>	<b><u>TROUBLE-SHOOTING DIAGRAM</u></b>
Circuits valid for Traction Controller	<p><b><u>SYMPTOM</u></b> Control will not operate.</p> <p><b><u>POSSIBLE CAUSE</u></b></p> <ul style="list-style-type: none"> <li>• Defective control. Replace controller unit.</li> <li>• Line contactor tips welded open. Replace line contactor.</li> <li>• Verify that there are no motor shorts.</li> <li>• Verify that there are no cable shorts between: B+ and F1 B+ and F2 A2 and F2 A1 and F2 F1 and F2</li> </ul>	

TRACTION STATUS CODE	DESCRIPTION OF STATUS	CAUSE OF STATUS INDICATION
<b>-67</b>	FET armature protection has shut down.	This status code will be displayed when the armature transistor SAT drop is high or line tips are open.
MEMORY RECALL <b>YES</b>	<b>CORRECTIVE ACTIONS</b>	<b><u>TROUBLE-SHOOTING DIAGRAM</u></b>
Circuits valid for Traction Controller	<p><b><u>SYMPTOM</u></b> Control will not operate.</p> <p><b><u>POSSIBLE CAUSE</u></b></p> <ul style="list-style-type: none"> <li>• Defective control. Replace controller unit.</li> <li>• Line contactor tips welded open. Replace line contactor.</li> <li>• Verify that there are no motor armature shorts.</li> <li>• Verify that there are no cable shorts between the following points: A1 and A2 B+ and A2 B- and A2</li> </ul>	

TRACTION STATUS CODE	DESCRIPTION OF STATUS	CAUSE OF STATUS INDICATION
<b>-68</b>	The PMT enable signal from the auxiliary (slave) control to the master control drops below 5V	This status code will be displayed when the voltage at master PL21 drops below 5V.
MEMORY RECALL <b>YES</b>	<b>CORRECTIVE ACTIONS</b>	<b><u>TROUBLE-SHOOTING DIAGRAM</u></b>
Circuits valid for Traction Controller	<p><b><u>SYMPTOM</u></b> Control will not operate.</p> <p><b><u>POSSIBLE CAUSE</u></b></p> <ul style="list-style-type: none"> <li>• Auxiliary control shut down. Check Auxiliary control for stored faults.</li> <li>• Verify the connection between the master control P21 and the auxiliary/slave control P10.</li> </ul>	

TRACTION STATUS CODE	DESCRIPTION OF STATUS	CAUSE OF STATUS INDICATION								
<b>-76</b>	Capacitor (1C) voltage too high.	This status code will be displayed when the voltage on the capacitor goes above limit voltage* during the regenerative braking cycle.								
MEMORY RECALL <b>YES</b>	<b>CORRECTIVE ACTIONS</b>	<b>TROUBLE-SHOOTING DIAGRAM</b>								
Circuits valid for Traction Controller	<p><b>SYMPTOM</b> Line contactor opens and closes, then opens and can only close by opening and closing the key switch.</p> <p><b>POSSIBLE CAUSE</b></p> <ul style="list-style-type: none"> <li>• Unplugging the battery connector during regenerative braking.</li> <li>• Line contactor bouncing open during regen.</li> <li>• Main power fuse opening during regen.</li> <li>• Intermittent battery plug connection.</li> </ul> <p>* Limit Voltage:</p> <table border="1"> <thead> <tr> <th>Limit</th> <th>Battery Voltage</th> </tr> </thead> <tbody> <tr> <td>50V</td> <td>36V</td> </tr> <tr> <td>70V</td> <td>48V</td> </tr> <tr> <td>96V</td> <td>72//80V</td> </tr> </tbody> </table>	Limit	Battery Voltage	50V	36V	70V	48V	96V	72//80V	
Limit	Battery Voltage									
50V	36V									
70V	48V									
96V	72//80V									

TRACTION STATUS CODE	DESCRIPTION OF STATUS	CAUSE OF STATUS INDICATION
<b>-77</b>	Motor current is detected during regenerative braking.	This status code will be displayed when motoring current is detected during the regenerative braking cycle.
MEMORY RECALL <b>YES</b>	<b>CORRECTIVE ACTIONS</b>	<b>TROUBLE-SHOOTING DIAGRAM</b>
Circuits valid for Traction Controller	<p><b>SYMPTOM</b> Line contactor opens and closes, then opens and can only close by opening and closing the key switch.</p> <p><b>POSSIBLE CAUSE</b> Defective control.</p> <ul style="list-style-type: none"> <li>• Replace controller unit</li> </ul>	

TRACTION STATUS CODE	DESCRIPTION OF STATUS	CAUSE OF STATUS INDICATION
<b>-80</b>	Voltage at capacitor (1C) is less than 14 volts.	This status code will be displayed when the voltage at the capacitor is less than 14 volts. This typically occurs during the run mode of operation.
MEMORY RECALL <b>YES</b>	<b>CORRECTIVE ACTIONS</b>	<b>TROUBLE-SHOOTING DIAGRAM</b>
Circuits valid for Traction Controller	<p><b>SYMPTOM</b> Control will not operate.</p> <p><b>POSSIBLE CAUSE</b> Line contactor opened during run.</p> <ul style="list-style-type: none"> <li>• Check connection from P17 to Line Coil (-) for loose connection.</li> <li>• Check connection from battery (+) to Line Coil (+) for loose connection.</li> <li>• Check power connection from battery (+) to contactor L.</li> <li>• Check for blown fuse element.</li> <li>• Check for contaminated contactor tips.</li> </ul>	

TRACTION STATUS CODE	DESCRIPTION OF STATUS	CAUSE OF STATUS INDICATION
<b>-81</b>	Battery voltage is less than 14 volts.	This status code will be displayed when the battery voltage measured at P1 is less than 14 volts.
MEMORY RECALL <b>YES</b>	<b>CORRECTIVE ACTIONS</b>	<b>TROUBLE-SHOOTING DIAGRAM</b>
Circuits valid for Traction Controller	<p><b>SYMPTOM</b> Control will not operate.</p> <p><b>POSSIBLE CAUSE</b> Line contactor opened during run.</p> <ul style="list-style-type: none"> <li>• Check connection from P17 to Line Coil (-) for loose connection.</li> <li>• Check connection from battery (+) to Line Coil (+) for loose connection.</li> <li>• Check power connection from battery (+) to contactor L.</li> <li>• Check for blown fuse element.</li> </ul>	

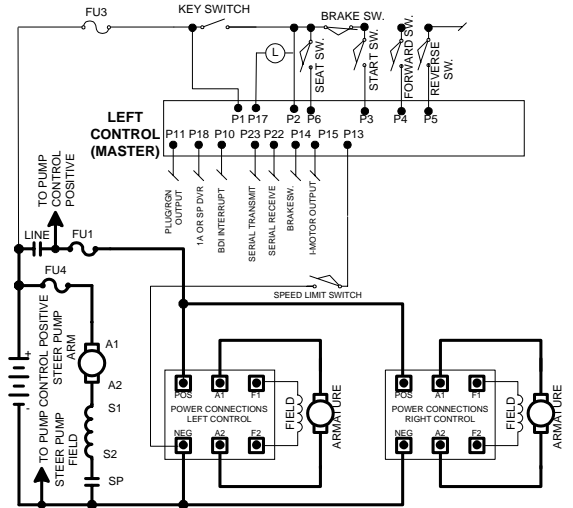
TRACTION STATUS CODE	DESCRIPTION OF STATUS	CAUSE OF STATUS INDICATION
<b>-84</b>	Battery voltage is less than 24 volts for more than 5 seconds.	This status code will be displayed when there is low battery voltage seen at P1.
MEMORY RECALL <b>NO</b>	<b>CORRECTIVE ACTIONS</b>	<b>TROUBLE-SHOOTING DIAGRAM</b> 
Circuits valid for Traction Controller	<p><b>SYMPTOM</b> Control will not operate.</p> <p><b>POSSIBLE CAUSE</b></p> <ul style="list-style-type: none"> <li>• Dead battery</li> <li>• High voltage drop in P1 sense lead</li> </ul>	

Section 4.5 TMM Codes

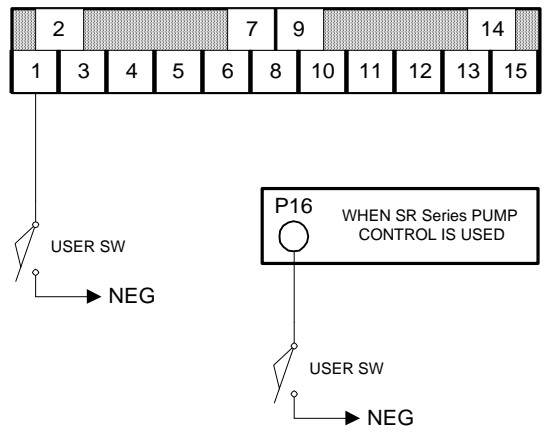
TRACTION STATUS CODE	DESCRIPTION OF STATUS	CAUSE OF STATUS INDICATION
<b>-90</b>	<b>USER DEFINED STATUS CODE</b> See instructions for Truck Management Module for details.	This status code will be displayed when the voltage at the respective terminal of the TMM or Pump Logic Card is at zero volts.
MEMORY RECALL <b>YES</b>	<b>CORRECTIVE ACTIONS</b>	<b>TROUBLE-SHOOTING DIAGRAM</b>  WHEN TMM7A CARD IS USED 
Circuits valid for Traction Controller & Pump Controller	<p><b>SYMPTOM</b> Status code flashes "on and off".</p> <p><b>POSSIBLE CAUSE</b> User defined status code is displayed by switch closure or motor brush sensor closure to negative.</p> <ul style="list-style-type: none"> <li>• See GEH-TMM7A, "Truck Management Module Instructions" for OEM defined status codes for complete corrective action required.</li> </ul> <p>Terminal 1 (TMM7A) is shorted to negative.</p> <p>Plug P16 (pump) is shorted to negative.</p> <p>Defective input switch (shorted).</p> <p>Defective TMM card.</p> <p>Defective pump card.</p>	

SC90

TRACTION STATUS CODE	DESCRIPTION OF STATUS	CAUSE OF STATUS INDICATION
<b>-91</b>	<b>USER DEFINED STATUS CODE</b> See instructions for Truck Management Module for details.	This status code will be displayed when the voltage at the respective terminal of the TMM or Pump Logic Card is at zero volts.
MEMORY RECALL <b>YES</b>	<b>CORRECTIVE ACTIONS</b>	<b>TROUBLE-SHOOTING DIAGRAM</b>
Circuits valid for Traction Controller & Pump Controller	<b>SYMPTOM</b> Status code flashes "on and off".	<p>WHEN TMM7A CARD IS USED</p>
	<p><b>POSSIBLE CAUSE</b> User defined status code is displayed by switch closure or motor brush sensor closure to negative.</p> <ul style="list-style-type: none"> <li>See GEH-TMM7A, "Truck Management Module Instructions" for OEM defined status codes for complete corrective action required.</li> </ul> <p>Terminal 3 (TMM7A) is shorted to negative.</p> <p>Plug P17 (pump) is shorted to negative.</p> <p>Defective input switch (shorted).</p> <p>Defective TMM card.</p> <p>Defective pump card.</p>	

SC91

TRACTION STATUS CODE	DESCRIPTION OF STATUS	CAUSE OF STATUS INDICATION
<b>-92</b>	<b>USER DEFINED STATUS CODE</b> See instructions for Truck Management Module for details.	This status code will be displayed when the voltage at the respective terminal of the TMM or Pump Logic Card is at zero volts.
MEMORY RECALL <b>YES</b>	<b>CORRECTIVE ACTIONS</b>	<b>TROUBLE-SHOOTING DIAGRAM</b>
Circuits valid for Traction Controller & Pump Controller	<b>SYMPTOM</b> Status code flashes "on and off".	<p>WHEN TMM7A CARD IS USED</p>
	<p><b>POSSIBLE CAUSE</b> User defined status code is displayed by switch closure or motor brush sensor closure to negative.</p> <ul style="list-style-type: none"> <li>See GEH-TMM7A, "Truck Management Module Instructions" for OEM defined status codes for complete corrective action required.</li> </ul> <p>Terminal 4 (TMM7A) is shorted to negative.</p> <p>Plug P15 (pump) is shorted to negative.</p> <p>Defective input switch (shorted).</p> <p>Defective TMM card.</p> <p>Defective pump card.</p>	

SC92

TRACTION STATUS CODE	DESCRIPTION OF STATUS	CAUSE OF STATUS INDICATION
<b>-93</b>	<b>USER DEFINED STATUS CODE</b> See instructions for Truck Management Module for details.	This status code will be displayed when the voltage at the respective terminal of the TMM or Pump Logic Card is at zero volts.
MEMORY RECALL <b>YES</b>	<b>CORRECTIVE ACTIONS</b>	<b>TROUBLE-SHOOTING DIAGRAM</b>
Circuits valid for Traction Controller & Pump Controller	<b>SYMPTOM</b> Status code flashes "on and off".	<p>WHEN TMM7A CARD IS USED</p>
	<p><b>POSSIBLE CAUSE</b> User defined status code is displayed by switch closure or motor brush sensor closure to positive.</p> <ul style="list-style-type: none"> <li>See GEH-TMM7A, "Truck Management Module Instructions" for OEM defined status codes for complete corrective action required.</li> </ul> <p>Terminal 5 (TMM7A) is shorted to positive.</p> <p>Plug P3 (pump) is shorted to positive.</p> <p>Defective input switch (shorted).</p> <p>Defective TMM card.</p> <p>Defective pump card.</p>	

SC93

TRACTION STATUS CODE	DESCRIPTION OF STATUS	CAUSE OF STATUS INDICATION
<b>-93</b>	<b>USER DEFINED STATUS CODE</b> See instructions for Truck Management Module for details.	This status code will be displayed when the voltage at the respective terminal of the TMM or Pump Logic Card is at zero volts.
MEMORY RECALL <b>YES</b>	<b>CORRECTIVE ACTIONS</b>	<b>TROUBLE-SHOOTING DIAGRAM</b>
Circuits valid for Traction Controller & Pump Controller	<b>SYMPTOM</b> Status code flashes "on and off".	<p>WHEN TMM7A CARD IS USED</p>
	<p><b>POSSIBLE CAUSE</b> User defined status code is displayed by switch closure or motor brush sensor closure to positive.</p> <ul style="list-style-type: none"> <li>See GEH-TMM7A, "Truck Management Module Instructions" for OEM defined status codes for complete corrective action required.</li> </ul> <p>Terminal 6 (TMM7A) is shorted to positive.</p> <p>Plug P4 (pump) is shorted to positive.</p> <p>Defective input switch (shorted).</p> <p>Defective TMM card.</p> <p>Defective pump card.</p>	

SC93A

TRACTION STATUS CODE	DESCRIPTION OF STATUS	CAUSE OF STATUS INDICATION
<b>-94</b>	<b>USER DEFINED STATUS CODE</b> See instructions for Truck Management Module for details.	This status code will be displayed when the voltage at the respective terminal of the TMM or Pump Logic Card is at zero volts.
MEMORY RECALL <b>YES</b>	<b>CORRECTIVE ACTIONS</b>	<b>TROUBLE-SHOOTING DIAGRAM</b>
Circuits valid for Traction Controller & Pump Controller	<p><b>SYMPTOM</b> Status code flashes "on and off".</p> <p><b>POSSIBLE CAUSE</b> User defined status code is displayed by switch closure or motor brush sensor closure to positive.</p> <ul style="list-style-type: none"> <li>See GEH-TMM7A, "Truck Management Module Instructions" for OEM defined status codes for complete corrective action required.</li> </ul> <p>Terminal 8 (TMM7A) is shorted to positive.</p> <p>Plug P5 (pump) is shorted to positive.</p> <p>Defective input switch (shorted).</p> <p>Defective TMM card.</p> <p>Defective pump card.</p>	<p>WHEN TMM7A CARD IS USED</p> <p>SC94</p>

TRACTION STATUS CODE	DESCRIPTION OF STATUS	CAUSE OF STATUS INDICATION
<b>-94</b>	<b>USER DEFINED STATUS CODE</b> See instructions for Truck Management Module for details.	This status code will be displayed when the voltage at the respective terminal of the TMM or Pump Logic Card is at zero volts.
MEMORY RECALL <b>YES</b>	<b>CORRECTIVE ACTIONS</b>	<b>TROUBLE-SHOOTING DIAGRAM</b>
Circuits valid for Traction Controller & Pump Controller	<p><b>SYMPTOM</b> Status code flashes "on and off".</p> <p><b>POSSIBLE CAUSE</b> User defined status code is displayed by switch closure or motor brush sensor closure to positive.</p> <ul style="list-style-type: none"> <li>See GEH-TMM7A, "Truck Management Module Instructions" for OEM defined status codes for complete corrective action required.</li> </ul> <p>Terminal 10 (TMM7A) is shorted to positive.</p> <p>Plug P6 (pump) is shorted to positive.</p> <p>Defective input switch (shorted).</p> <p>Defective TMM card.</p> <p>Defective pump card.</p>	<p>WHEN TMM7A CARD IS USED</p> <p>SC94A</p>

TRACTION STATUS CODE	DESCRIPTION OF STATUS	CAUSE OF STATUS INDICATION
<b>-95</b>	<b>USER DEFINED STATUS CODE</b> See instructions for Truck Management Module for details.	This status code will be displayed when the voltage at the respective terminal of the TMM or Pump Logic Card is at zero volts.
MEMORY RECALL <b>YES</b>	<b>CORRECTIVE ACTIONS</b>	<b>TROUBLE-SHOOTING DIAGRAM</b>
Circuits valid for Traction Controller & Pump Controller	<p><b>SYMPTOM</b> Status code flashes "on and off".</p> <p><b>POSSIBLE CAUSE</b> User defined status code is displayed by switch closure or motor brush sensor closure to positive.</p> <ul style="list-style-type: none"> <li>See GEH-TMM7A, "Truck Management Module Instructions" for OEM defined status codes for complete corrective action required.</li> </ul> <p>Terminal 11 (TMM7A) is shorted to positive.</p> <p>Plug P8 (pump) is shorted to positive.</p> <p>Defective input switch (shorted).</p> <p>Defective TMM card.</p> <p>Defective pump card.</p>	<p>WHEN TMM7A CARD IS USED</p> <p>SC95</p>

TRACTION STATUS CODE	DESCRIPTION OF STATUS	CAUSE OF STATUS INDICATION
<b>-95</b>	<b>USER DEFINED STATUS CODE</b> See instructions for Truck Management Module for details.	This status code will be displayed when the voltage at the respective terminal of the TMM or Pump Logic Card is at zero volts.
MEMORY RECALL <b>YES</b>	<b>CORRECTIVE ACTIONS</b>	<b>TROUBLE-SHOOTING DIAGRAM</b>
Circuits valid for Traction Controller & Pump Controller	<p><b>SYMPTOM</b> Status code flashes "on and off".</p> <p><b>POSSIBLE CAUSE</b> User defined status code is displayed by switch closure or motor brush sensor closure to positive.</p> <ul style="list-style-type: none"> <li>See GEH-TMM7A, "Truck Management Module Instructions" for OEM defined status codes for complete corrective action required.</li> </ul> <p>Terminal 12 (TMM7A) is shorted to positive.</p> <p>Plug P9 (pump) is shorted to positive.</p> <p>Defective input switch (shorted).</p> <p>Defective TMM card.</p> <p>Defective pump card.</p>	<p>WHEN TMM7A CARD IS USED</p> <p>SC95A</p>

PUMP STATUS CODE	DESCRIPTION OF STATUS	CAUSE OF STATUS INDICATION
<b>-102</b>	Key switch is open for more than 8 seconds while the SL2 switch is closed	This status code will be displayed when SL2 is closed with key switch off.
MEMORY RECALL <b>YES</b>	<b>CORRECTIVE ACTIONS</b>	<b><u>TROUBLE-SHOOTING DIAGRAM</u></b>
Circuits valid for Pump Controller	<p><b><u>SYMPTOM:</u></b></p> <ul style="list-style-type: none"> <li>Speed limit 2 is closed and vehicle will not exceed the speed indicated by SL2.</li> </ul> <p><b><u>POSSIBLE CAUSE:</u></b></p> <ul style="list-style-type: none"> <li>Defective SL2 switch. Replace SL2 switch.</li> </ul>	

PUMP STATUS CODE	DESCRIPTION OF STATUS	CAUSE OF STATUS INDICATION
<b>-103</b>	Key switch is open for more than 8 seconds while the SL3 switch is closed	This status code will be displayed when SL3 is closed with the key switch off.
MEMORY RECALL <b>YES</b>	<b>CORRECTIVE ACTIONS</b>	<b><u>TROUBLE-SHOOTING DIAGRAM</u></b>
Circuits valid for Pump Controller	<p><b><u>SYMPTOM:</u></b></p> <ul style="list-style-type: none"> <li>Speed limit 3 is closed and vehicle will not exceed the speed indicated by SL3.</li> </ul> <p><b><u>POSSIBLE CAUSE:</u></b></p> <ul style="list-style-type: none"> <li>Defective SL3 switch. Replace SL3 switch.</li> </ul>	

PUMP STATUS CODE	DESCRIPTION OF STATUS	CAUSE OF STATUS INDICATION
<b>-104</b>	Key switch is open for more than 8 seconds while the SL4 switch is closed	This status code will be displayed when SL4 is closed with key switch off.
MEMORY RECALL <b>YES</b>	<b>CORRECTIVE ACTIONS</b>	<b><u>TROUBLE-SHOOTING DIAGRAM</u></b>
Circuits valid for Pump Controller	<p><b><u>SYMPTOM:</u></b></p> <ul style="list-style-type: none"> <li>Speed limit 4 is closed and vehicle will not exceed the speed indicated by SL4.</li> </ul> <p><b><u>POSSIBLE CAUSE:</u></b></p> <ul style="list-style-type: none"> <li>Defective SL4 switch. Replace SL4 switch.</li> </ul>	

PUMP STATUS CODE	DESCRIPTION OF STATUS	CAUSE OF STATUS INDICATION
<b>-117</b>	"Card Type" selection is invalid.	This status code will be displayed when the card type selection value is set to an invalid number.
MEMORY RECALL <b>NO</b>	<b>CORRECTIVE ACTIONS</b>	<b><u>TROUBLE-SHOOTING DIAGRAM</u></b>
Circuits valid for Pump Controller	<p><b><u>SYMPTOM:</u></b> Pump contactors will not close.</p> <p><b><u>POSSIBLE CAUSE:</u></b> Invalid card type selection.</p> <ul style="list-style-type: none"> <li>Review function 17 in the Handset Instruction sheets. Adjust and set card type value as instructed by OEM service manual.</li> </ul>	<p><b>NO GRAPHIC FOR THIS STATUS CODE</b></p>

PUMP STATUS CODE	DESCRIPTION OF STATUS	CAUSE OF STATUS INDICATION
<b>-123</b>	Pump contactor coil current is low.	This code will be displayed when the pump contactor coil circuit current draw is less than 100 milliamps.
MEMORY RECALL <b>NO</b>	<b>CORRECTIVE ACTIONS</b>	<b>TROUBLE-SHOOTING DIAGRAM</b>
Circuits valid for Pump Controller	<p><b>SYMPTOM:</b> Pump contactor will not pick up. Status code may alternate between code 123 and code 124. Complete check for code 123, if the problem is not found, perform check for code 124.</p> <p><b>POSSIBLE CAUSE:</b> Defective Pump contactor coil circuit.</p> <ul style="list-style-type: none"> <li>• Check for open circuit or loose connection between P2 and positive side of P contactor coil.</li> <li>• Remove plug B. Check ohmic value from P2 to positive side of P coil. Value should be between 10 and 14 ohms.</li> </ul> <p>Defective 1A contactor coil.</p> <ul style="list-style-type: none"> <li>• Remove plug. Check ohmic value from positive side of coil to its plug connection. Value should be between 10 and 14 ohms.</li> </ul>	

PUMP STATUS CODE	DESCRIPTION OF STATUS	CAUSE OF STATUS INDICATION
<b>-124</b>	T2 voltage is low. (Less than 88% of battery voltage.)	This status code is displayed when T2 voltage is less than 88% of battery volts and the Pump driver is energized.
MEMORY RECALL <b>NO</b>	<b>CORRECTIVE ACTIONS</b>	<b>TROUBLE-SHOOTING DIAGRAM</b>
Circuits valid for Pump Controller	<p><b>SYMPTOM:</b> Control does not operate. Status code may alternate between code 123 and code 124. Complete checks for 124, if the problem is not found, perform code 123 check.</p> <p><b>POSSIBLE CAUSE:</b> Defective Pump contactor.</p> <ul style="list-style-type: none"> <li>• Pump power tips fail to close because:             <ol style="list-style-type: none"> <li>1) Welded normally closed power tips.</li> <li>2) Binding contactor tip assembly.</li> <li>3) Defective Pump contactor coil. ( See status code 123)</li> </ol> </li> </ul> <p>Open motor circuit</p> <ul style="list-style-type: none"> <li>• Check for open circuit or loose connection in pump motor circuit from the A1 connection to the A2 connection on the control panel.</li> </ul> <p>Defective 1A contactor.</p> <ul style="list-style-type: none"> <li>• Perform checks as outlined in status 123.</li> </ul>	

PUMP STATUS CODE	DESCRIPTION OF STATUS	CAUSE OF STATUS INDICATION
<b>-127</b>	Logic card power supply is less than 10 VDC.	This status code is displayed when the logic card power supply is less than 10 volts.
MEMORY RECALL <b>YES</b>	<b>CORRECTIVE ACTIONS</b>	<b>TROUBLE-SHOOTING DIAGRAM</b>
Circuits valid for Pump Controller	<p><b>SYMPTOM:</b> Pump contactor opens and closes, then can only be closed by opening and closing the key switch.</p> <p><b>POSSIBLE CAUSE:</b></p> <ul style="list-style-type: none"> <li>Discharged battery</li> <li>Check battery to insure proper state of charge.</li> <li>Loose connection at P1.</li> </ul> <p>Insure that the wire connection at PB1 is tight.</p> <ul style="list-style-type: none"> <li>Defective controller.</li> </ul> <p>Replace control.</p>	

PUMP STATUS CODE	DESCRIPTION OF STATUS	CAUSE OF STATUS INDICATION
<b>-128</b>	Armature current is greater than 300A for longer than 70 seconds	This status code is displayed when armature current is maintained at a level above 300A for >70 seconds.
MEMORY RECALL <b>YES</b>	<b>CORRECTIVE ACTIONS</b>	<b>TROUBLE-SHOOTING DIAGRAM</b>
Circuits valid for Pump Controller	<p><b>SYMPTOM:</b> Pump contactor opens and closes, then can only be closed by opening and closing the key switch.</p> <p><b>POSSIBLE CAUSE:</b></p> <p>Discharged battery</p> <ul style="list-style-type: none"> <li>Check battery to insure proper state of charge.</li> <li>Loose connection at P1.</li> <li>Insure that the wire connection at PB1 is tight.</li> </ul> <p>Defective controller unit.</p> <ul style="list-style-type: none"> <li>Replace control.</li> </ul>	

PUMP STATUS CODE	DESCRIPTION OF STATUS	CAUSE OF STATUS INDICATION
<b>-141</b>	Open thermal protector (TP1) or transistor is over temperature.	This status code is displayed when the internal heatsink temperature of the control exceeds 90 degrees.
MEMORY RECALL <b>NO</b>	<b>CORRECTIVE ACTIONS</b>	<b><u>TROUBLE-SHOOTING DIAGRAM</u></b>
Circuits valid for Pump Controller	<p><b><u>SYMPTOM:</u></b>                      Reduced or no power to pump motor in control range.</p> <p><b><u>POSSIBLE CAUSE:</u></b>                      Control is in thermal cut-back.</p> <ul style="list-style-type: none"> <li>• Allow control to cool, status code should disappear.</li> <li>• If control cools to ambient temperature and the fault remains when the control is restarted, replace the control.</li> </ul>	<p><b>NO                      GRAPHIC                      FOR THIS                      STATUS CODE</b></p>

PUMP STATUS CODE	DESCRIPTION OF STATUS	CAUSE OF STATUS INDICATION
<b>-142</b>	Pump Controller "motor current sensor" input is missing.	This status code is displayed when the voltage at the current sensor is greater than 0.1 volts with no current flowing in the motor circuit.
MEMORY RECALL <b>NO</b>	<b>CORRECTIVE ACTIONS</b>	<b><u>TROUBLE-SHOOTING DIAGRAM</u></b>
Circuits valid for Pump Controller	<p><b><u>SYMPTOM:</u></b>                      No power to pump motor in control range.</p> <p><b><u>POSSIBLE CAUSE:</u></b>                      Defective controller unit.</p> <ul style="list-style-type: none"> <li>• Replace control.</li> </ul>	<p><b>NO                      GRAPHIC                      FOR THIS                      STATUS CODE</b></p>

PUMP STATUS CODE	DESCRIPTION OF STATUS	CAUSE OF STATUS INDICATION
<b>-143</b>	Pump Controller "motor current sensor" input is too low.	This status code is displayed when the voltage at the current sensor is greater than 0.1 volts with no current flowing in the motor circuit.
MEMORY RECALL <b>NO</b>	<b>CORRECTIVE ACTIONS</b>	<u><b>TROUBLE-SHOOTING DIAGRAM</b></u>  <b>NO                  GRAPHIC                  FOR THIS                  STATUS CODE</b>
Circuits valid for Pump Controller	<p><b><u>SYMPTOM:</u></b>                      No power to pump motor in control range.</p> <p><b><u>POSSIBLE CAUSE:</u></b>                      Control is defective.</p> <ul style="list-style-type: none"> <li>• Replace controller unit.</li> </ul>	

PUMP STATUS CODE	DESCRIPTION OF STATUS	CAUSE OF STATUS INDICATION
<b>-144</b>	Power Transistor (Q1) did not turn off properly.	This status code is displayed when, during pump control operation, the Q1 transistor fails to turn off. This will result in a PMT condition.
MEMORY RECALL <b>YES</b>	<b>CORRECTIVE ACTIONS</b>	<u><b>TROUBLE-SHOOTING DIAGRAM</b></u>  <b>NO                  GRAPHIC                  FOR THIS                  STATUS CODE</b>
Circuits valid for Pump Controller	<p><b><u>SYMPTOM:</u></b>                      With no pump contactor, control may run continuously.</p> <p><b><u>POSSIBLE CAUSE:</u></b>                      Control is defective.</p> <ul style="list-style-type: none"> <li>• Replace controller unit.</li> </ul>	

PUMP STATUS CODE	DESCRIPTION OF STATUS	CAUSE OF STATUS INDICATION
<b>-145</b>	Power Transistor (Q1) did not turn on properly.	This status code is displayed when during pump control operation, the transistor fails to turn on.
MEMORY RECALL <b>YES</b>	<b>CORRECTIVE ACTIONS</b>	<b><u>TROUBLE-SHOOTING DIAGRAM</u></b>
Circuits valid for Pump Controller	<p><b><u>SYMPTOM:</u></b> Pump contactor will open and close, then open and then can only be closed by opening and closing the key switch.</p> <p><b><u>POSSIBLE CAUSE:</u></b> Control is defective.</p> <ul style="list-style-type: none"> <li>• Replace controller unit.</li> </ul>	

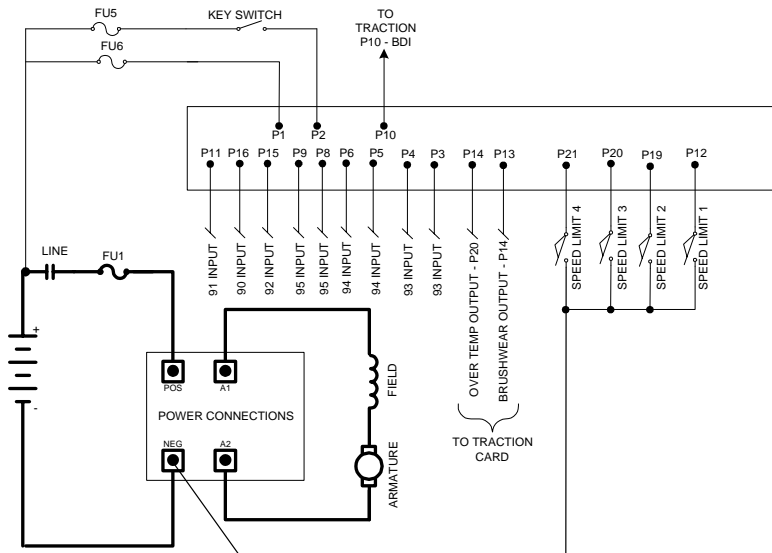

PUMP STATUS CODE	DESCRIPTION OF STATUS	CAUSE OF STATUS INDICATION
<b>-146</b>	"Look Ahead" test for T2 volts less than 12% of battery volts.	This status code will be displayed when the voltage at A2 is less than 12% of battery volts.
MEMORY RECALL <b>YES</b>	<b>CORRECTIVE ACTIONS</b>	<b><u>TROUBLE-SHOOTING DIAGRAM</u></b>
Circuits valid for Pump Controller	<p><b><u>SYMPTOM:</u></b> Pump control will not operate.</p> <p><b><u>POSSIBLE CAUSE:</u></b> Check for short circuit from the motor armature to the frame of the vehicle.</p> <p>Defective controller unit.</p> <ul style="list-style-type: none"> <li>• Replace control.</li> </ul>	

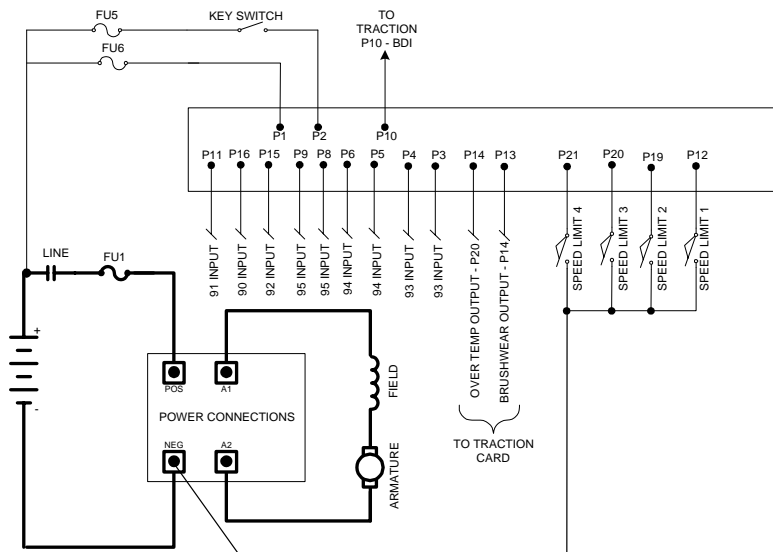

PUMP STATUS CODE	DESCRIPTION OF STATUS	CAUSE OF STATUS INDICATION
<b>-151</b>	Capacitor volts are low before the line contactor closes. (Internal card function during precharge)	This status code will be displayed during "key on" when the capacitor volts is less than 85% of battery volts at initial key switch on.
MEMORY RECALL <b>NO</b>	<b>CORRECTIVE ACTIONS</b>	<b><u>TROUBLE-SHOOTING DIAGRAM</u></b>
Circuits valid for Pump Controller	<p><b><u>SYMPTOM:</u></b> Line contactor does not close when Capacitor does not pre-charge.</p> <p><b><u>POSSIBLE CAUSE:</u></b> Defective control fuse.  <ul style="list-style-type: none"> <li>• Check control fuse for open circuit, replace fuse, if necessary.</li> </ul>                     Defective control.  <ul style="list-style-type: none"> <li>• Replace controller unit.</li> </ul> </p> <p><i>Note: Repeated charging/discharging the capacitors during troubleshooting will cause status code 51. Also do not connect <b>any</b> loads to the load side of the line contactor.</i></p>	

PUMP STATUS CODE	DESCRIPTION OF STATUS	CAUSE OF STATUS INDICATION
<b>-157</b>	Controller "motor current sensor" input voltage polarity check.	This status code will be displayed when the voltage input to PZ13 and PZ12 is of the wrong polarity.
MEMORY RECALL <b>NO</b>	<b>CORRECTIVE ACTIONS</b>	<b><u>TROUBLE-SHOOTING DIAGRAM</u></b>
Circuits valid for Pump Controller	<p><b><u>SYMPTOM:</u></b> Pump control will not operate.</p> <p><b><u>POSSIBLE CAUSE:</u></b> Control is defective.  <ul style="list-style-type: none"> <li>• Replace controller unit.</li> </ul> </p>	

PUMP STATUS CODE	DESCRIPTION OF STATUS	CAUSE OF STATUS INDICATION
<b>-180</b>	Voltage at capacitor (1C) is less than 14 volts.	This status code will be displayed when the voltage between B+ and B- buss bar is less than 14 volts. This occurs typically in the run mode of operation.
MEMORY RECALL <b>NO</b>	<b>CORRECTIVE ACTIONS</b>	<b>TROUBLE-SHOOTING DIAGRAM</b>
Circuits valid for Pump Controller	<p><b>SYMPTOM:</b> Control will not operate.</p> <p><b>POSSIBLE CAUSE:</b> Line Contactor opened up during run.</p> <ul style="list-style-type: none"> <li>• Check connection from P17 to Line coil (-) for loose connection.</li> <li>• Check connection from battery (+) to Line coil (+) for loose connection.</li> <li>• Check power connection from battery (+) to contactor L.</li> <li>• Check for blown fuse element.</li> <li>• Check for dirty contactor tips.</li> </ul>	

PUMP STATUS CODE	DESCRIPTION OF STATUS	CAUSE OF STATUS INDICATION
<b>-181</b>	Battery voltage is less than 14 volts.	This status code will be displayed when the battery voltage measured at P1 is less than 14 volts.
MEMORY RECALL <b>NO</b>	<b>CORRECTIVE ACTIONS</b>	<b>TROUBLE-SHOOTING DIAGRAM</b>
Circuits valid for Pump Controller	<p><b>SYMPTOM:</b> Pump control will not operate.</p> <p><b>POSSIBLE CAUSE:</b> Line Contactor opened during run.</p> <ul style="list-style-type: none"> <li>• Check connection from P17 to Line coil (-) for loose connection.</li> <li>• Check connection from battery (+) to Line coil (+) for loose connection.</li> <li>• Check power connection from battery (+) to contactor L.</li> <li>• Check for blown fuse element.</li> </ul>	

## Section 5. TRUCK MANAGEMENT MODULE (TMM)

### Section 5.1 General Features

The Truck Management Module is a multi-functional accessory card (IC3645TMM7A), or an integral function of the SR Pump control when used with the SX Family of Traction controls. The Module provides the OEM with the ability to initiate status codes or operator warning codes to be displayed on the Dash Display whenever a normally open switch or sensor wire provides a signal to the Module.

The TMM Module can be used to display a separate status code indicating an over temperature of traction motors, hydraulic motors, or any other device or system that can activate a switch that closes.

It can also be used as a Brush Wear Indicator (BWI). The Brush Wear Indicator is designed to detect a "worn-out brush" and display a fault code on the Dash Display to warn maintenance personnel that the motor brushes need to be replaced before they wear to the point of causing destructive damage to the motor commutator surface. The BWI function is compatible with any sensor that short circuits to the motor armature to signal limits of brush wear.

**Note: Motor armature must be in the positive side of the battery circuit.**

### Section 5.2 Operation

The Module utilizes 9 OEM input points and 3 output points that connect to the "Y" plug on the traction logic card. **Due to the low level signal value of this output, shielded wire should always be used to insure proper operation.** The input to the Module is either a switch or sensor wire closure to battery negative or positive. The following table outlines the status code displayed for each input, when that point is closed to battery negative or positive, as indicated.

TMM7A Card Terminal	Pump Control Terminal	Status Code	Connect To
TB1	P16	90 *	Neg
TB3	P11	91	Neg
TB4	P15	92	Neg
TB5	P3	93 *	Pos
TB6	P4	93 *	Pos
TB8	P5	94	Pos
TB10	P6	94	Pos
TB11	P8	95	Pos
TB12	P9	95	Pos

\* Status codes 90 and 93 can also be programmed with the Handset to reduce the speed of the truck from 100 to 0 percent-on-time.

**IMPORTANT NOTE:** Status Codes 93, 94 and 95 are only checked when a neutral signal is present (i.e., open start switch or open F/R switch). The status code is displayed and the speed limit enabled when the control is returned to the run mode. Do not use status code 93 speed limit for applications requiring immediate speed limit on switch closure.

Typical wiring diagrams and outline drawings for the TMM7A accessory card and SR family of Pump TMM functions are shown in Sections 6.4 and 6.5.

### Section 5.3 Installation

**WARNING:** Before any adjustments, servicing or act requiring physical contact with working components, jack drive wheels off the floor, disconnect the battery and discharge the capacitors in the traction and pump controls, as explained in Section 15.3.

The TMM7A accessory card should be mounted to a flat surface (in any plane) in an area protected from water, oil and battery acid. Mounting dimensions are shown in Section 6.5. Two (0.187 inch, 4.75mm) mounting holes are provided.

### Section 5.4 Connection Diagrams

#### Section 5.4.1 TMM7A Card Connections

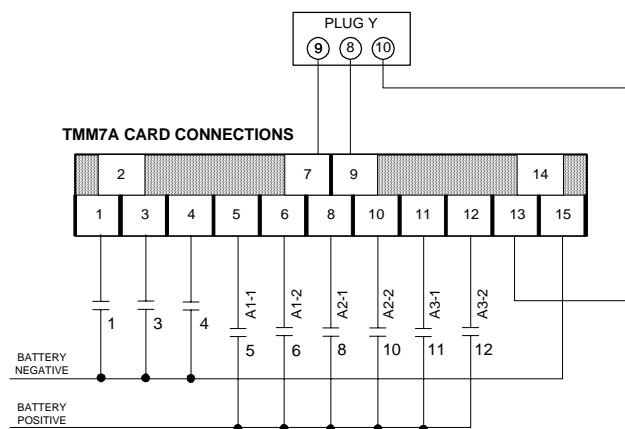

#### Section 5.4.2 Typical Brush Wear Sensor Connections

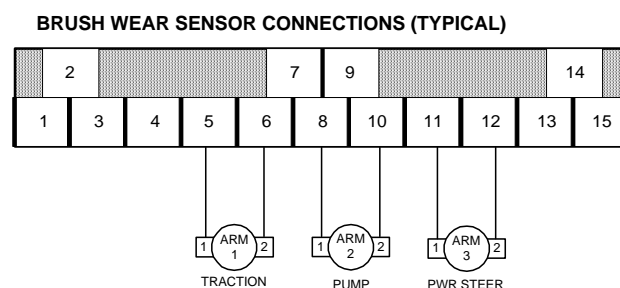

**Section 5.4.3 TMM Pump Control Connections**

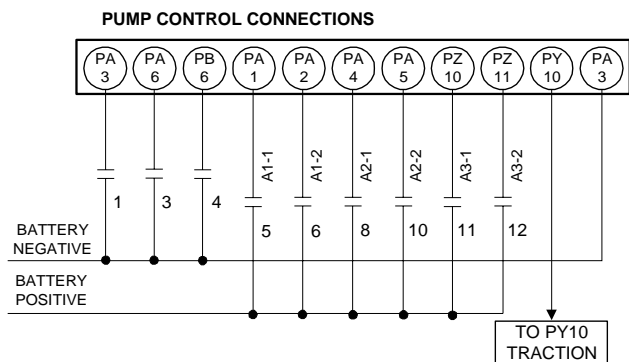

**Section 5.4.4 Typical Brush Wear Sensor Connections For Pump Control**

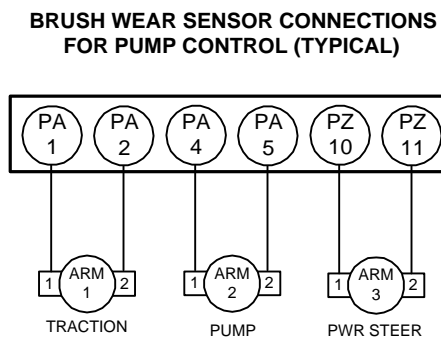

**Section 5.5 TMM7A Outline Drawings**

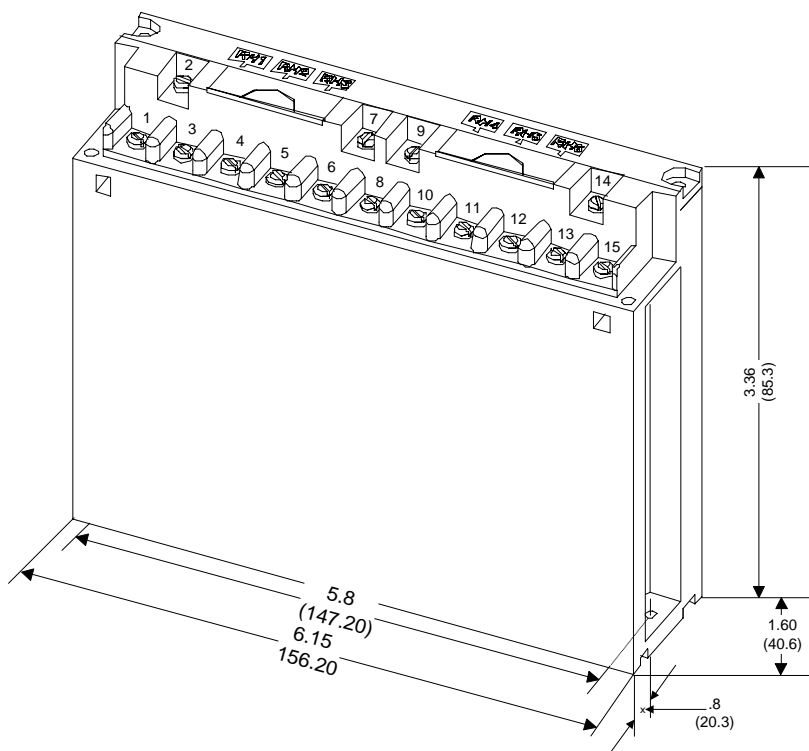

**Section 6.0 SX FAMILY GE HANDSET INSTRUCTIONS**

**Section 6.1 General Features**

The GE Handset is a multi-functional tool to be used with the LX, ZX, and SX Series GE solid-state controls. The Handset consists of a Light Emitting Diode (LED) display and a keyboard for data entry. *Note: A different handset cord is required for use with SX controls than that used with LX and ZX controls.*

**Section 6.2 Purpose / Setup Functions**

The purpose of the Handset is to allow authorized personnel to perform the following functions of the SX family of Controls:

- Monitor existing system fault codes
- Monitor intermittent random fault codes
- Monitor battery state of charge on systems with BDI
- Monitor hourmeter reading
- Monitor or adjust the following control functions:
  - Creep speed
  - Armature Controlled Acceleration and 1A Time
  - Regenerative Braking Current Limit and Disable
  - Armature and Field Current Limit
  - Plugging Distance (Current)
  - Pedal Position Plug Range or Disable
  - 1A Drop Out Current or Disable
  - Speed Limit Points
  - Truck Management Fault Speed Limit
  - Internal Resistance Compensation for Battery State of Charge Indication
  - Battery Voltage (36/48 volts is auto ranging)
  - Selection of Card Operation Type.

**Warning: Before connecting or disconnecting the Handset tool, turn off the key switch, unplug the battery and jack up the drive wheels of the vehicle.**

At the transistor control traction card, unplug the "Y plug" if the dash display is in use, and plug in the Handset to the plug location "Y" on the control card. After installing the Handset tool, plug the battery in and turn the key switch on. The chart at the right details the start-up display sequence that will occur.

**Note: The dash display must be disconnected when the Handset is plugged in, or the control power supply will be overloaded.**

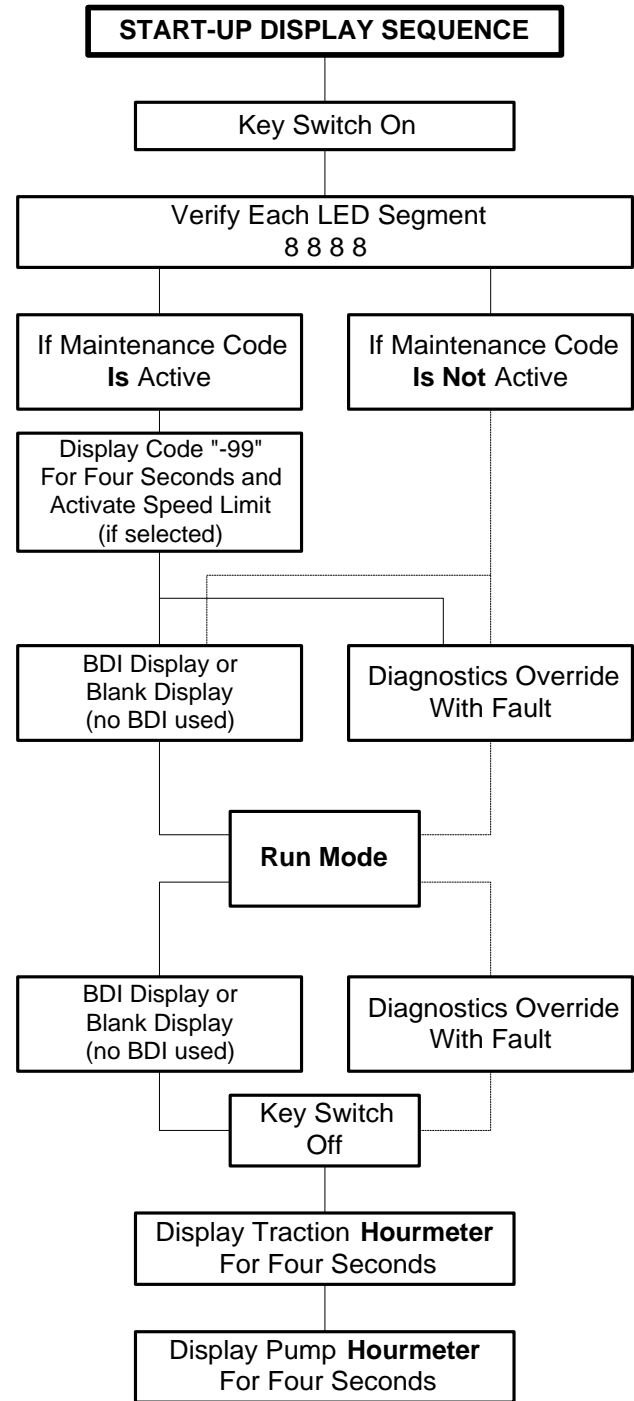

*Warning: Before making any adjustments to the control, you must consult the operating and maintenance instructions supplied by the vehicle manufacturer. Failure to follow proper set up instructions could result in mis-operation or damage to the control system.*

### Section 6.3 Setup Function Procedures

With the Handset connected, hold down the **CONT** key and turn on the key switch. This will place you in the setup mode, ready to monitor or adjust control function settings.

**NOTE:** The term "Push" means to depress key for approximately one second.

#### Section 6.3.1 Setup Mode

SET-UP MODE		
ACTION	DISPLAY SHOWS	REMARKS
Hold Down <b>CONT</b> And Turn On Key	<b>8 8 8 8</b>	Segment Check Displayed
Push Function Number	<b>U 0 0 5</b>	Selected Function No. Is Displayed
After One Second Time Delay	<b>0 8 5</b>	Stored Value For The Function Is Displayed
Push <b>CONT</b>	<b>0 8 5</b>	Display Value Will Blink
Change Value with Adjustment Knob	<b>1 2 5</b>	Value Changes While Blinking
Push <b>STORE</b>	<b>1 2 5</b>	New Value Stored And Blinking Stops
Push <b>ESC</b>	<b>8 8 8 8</b>	Segment Check Displayed

At this point, another function can be monitored/changed by pushing another function number, or the vehicle can be placed in the run mode by holding the **ESC** key down for one second or longer. The display will return to either the diagnostics mode, the BDI display, or a blank display (if BDI is not used and there are no fault codes). The vehicle can now be operated with the Handset connected or the Handset can be disconnected before operation.

**NOTE:** You can return to the segment check mode at any time, by holding down the **ESC** key until **8888** appears in the display.

#### Section 6.3.2 Status Code Scrolling

The SX family of controllers furnishes a function register that contains the last 16 "stored status codes" that shut down vehicle operation (a PMT type fault that is reset by cycling the key switch) and the battery state of charge

reading at the time the fault occurred. The first of the 16 status codes will be overwritten each time a new status code occurs. This stored status code register can be cleared from memory by using the Handset.

#### ACCESSING STORED STATUS CODES WITH GE HANDSET

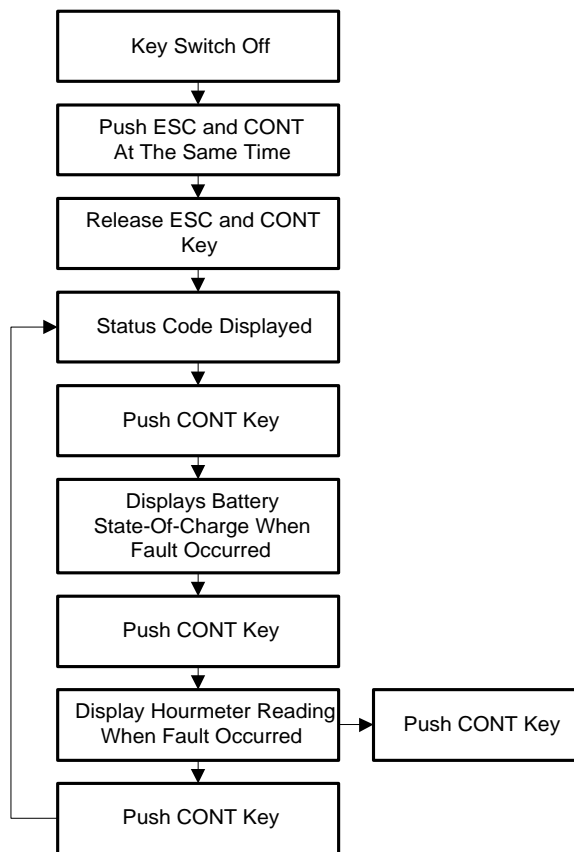

#### Section 6.3.3 SX Family Handset, Plug Connections and Outline Drawing

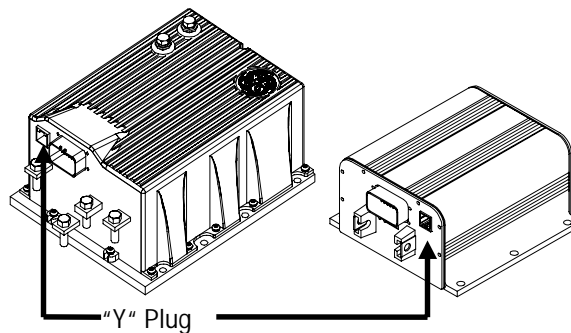

Handset Cable Part Number - 328A1550ATP1 (12 pin plug)  
Handset Part Number - IC3645LXHS1EC2 (12 pin plug)  
(includes handset, cable and case)

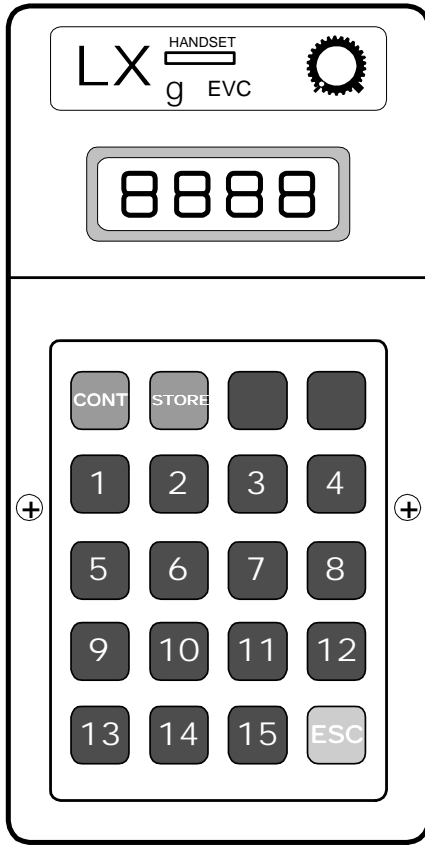

**Section 6.4 Setup Functions for Traction Controller**

**FUNCTION 1 MPH SCALING (When Used)**  
(Push 1)

This function allows for the pulses from the tachometer to be scaled to miles per hour, based on the number of pulses received by the control in a given time. For example, if you were scaling to 8 MPH, it would correspond to the length of time that it took to capture 8 tachometer pulses when the vehicle is traveling at 8 MPH.

Range 0 to 1.28 seconds  
Set 0 to 255  
Resolution 0.005 seconds per set unit  
Example: Setting of 20 = 0.1 seconds

**FUNCTION 2 CREEP SPEED**  
(Push 2)

This function allows for the adjustment of the creep speed of the vehicle. Creep speed can be adjusted when an accelerator input voltage between 3.9 and 3.3 volts or an accelerator ohm input between 6.0 K and 4.0K ohms is provided.

Range 2% to 15% on time  
Set 0 to 255

Resolution 0.05% per set unit  
Example: Setting of 20 = 3% on time

*Important Note: The function is used to optimize motor and control performance and this setting will be determined by GE and OEM engineers at the time of vehicle development. This setting must not be changed by field personnel without the permission of the OEM.*

**FUNCTION 3 ARMATURE CONTROLLED ACCELERATION AND 1A TIME**  
(Push 3)

This function allows for the adjustment of the rate of time it takes for the control to accelerate to 100% applied battery voltage to the motor on hard acceleration.

Range 0.1 to 25.5 seconds  
Set 1 to 255  
Resolution 0.1 seconds per set unit  
Example: Setting of 20 = 2.0 seconds  
C/A and 1A Time = 2.2 seconds

**FUNCTION 4 ARMATURE CURRENT LIMIT**  
(Push 4)

This function allows for the adjustment of the armature current limit of the control. The rating of the control will determine the range of adjustment for this function. Please refer to the operating instructions and current limit curves for the control used in specific vehicle.

Range See control C/L curves  
Set 0 to 255  
Example: 0 = min. current,  
255 = max. current

**FUNCTION 5 PLUGGING CURRENT LIMIT**  
(Push 5)

This function allows for the adjustment of the plugging distance of the vehicle. The larger the current setting, the shorter the stopping distance.

Min	Max	Set	Resolution Per unit value	Example If set at 20
55	455	0 to 255	1.57 amps	86.4 amps

*Important Note: The function is used to optimize motor and control performance and this setting will be determined by GE and OEM engineers at the time of vehicle development. This setting must not be changed by field personnel without the permission of the OEM.*

**FUNCTION 6 PUMP ENABLE SELECT**  
(Push 6)

If > 250 Activated on normal BDI operation  
if < 250 Lock out on pump enable on maintenance speed limit and BDI operation

**FUNCTION 7 MIN. FIELD CURRENT**  
(Push 7)

This function allows the adjustment of the field weakening level in order to set the top speed of the motor.

Min	Max	Set	Resolution Per unit value	Example If set at 71
0	40	51 to 255	0.185 amps	3.7 amps

*Important Note: The function is used to optimize motor and control performance and this setting will be determined by GE and OEM engineers at the time of vehicle development. This setting must not be changed by field personnel without the permission of the OEM.*

**FUNCTION 8 MAX FIELD CURRENT**  
(Push 8)

This function allows for the adjustment of the maximum field current in order to obtain the maximum torque of the motor.

Min	Max	Set	Resolution Per unit value	Example If set at 71
0	40	51 to 255	0.185 amps	3.7 amps

*Important Note: The function is used to optimize motor and control performance and this setting will be determined by GE and OEM engineers at the time of vehicle development. This setting must not be changed by field personnel without the permission of the OEM.*

**FUNCTION 9 REGEN BRAKING CURRENT LIMIT**  
(Push 9)

This function allows for the adjustment of the regen braking current limit.

Min	Max	Set	Resolution Per unit value	Example If set at 20
52	468	0 to 255	1.63 amps	84.6 amps

**FUNCTION 10 MAX FIELD CURRENT FOR REGEN**  
(Push 10)

This function allows for the adjustment of the maximum field current to be used during the regen braking mode.

Min	Max	Set	Resolution Per unit value	Example If set at 71
0	40	51 to 255	0.185 amps	3.7 amps

*Important Note: The function is used to optimize motor and control performance and this setting will be determined by GE and OEM engineers at the time of vehicle development. This setting must not be changed by field personnel without the permission of the OEM.*

**FUNCTION 11 SPEED LIMIT 1**  
(Push 11)

This function allows for the adjustment of the speed limit (maximum battery volts to the motor) when the SL1 limit switch input signal is received by the control card. The SL1 limit switch is a normally closed switch connected to battery negative, the switch opening enables speed limit.

Range	100% to 0% of battery volts
Set	51 to 180
Resolution	0.78% per set unit
Example:	Setting of 71 = 84% of battery volts

**FUNCTION 12 SPEED LIMIT 2**  
(Push 12)

Same as Function 11, except using input from the SL2 limit switch.

**FUNCTION 13 SPEED LIMIT 3**  
(Push 13)

The SL3 speed limit is activated by the Truck Management Module fault code 93. See Section 6 for Truck Management Module details.

**FUNCTION 14 INTERNAL RESISTANCE COMPENSATION**  
(Push 14)

This function is used when the Battery Discharge Indicator is present. Adjustment of this function will improve the accuracy of the BDI. In order to determine this setting, the voltage drop of the battery under load must first be calculated by the following method:

1. Record open circuit voltage ( $V_0$ ) by measuring the voltage at the control positive and negative power terminals.
2. Load the traction motor to 100 amps in 1A and record the voltage ( $V_L$ ) at the control positive and negative power terminals.
3. Calculate voltage drop ( $V_{Drop}$ ) as follows:  
$$V_{Drop} = V_0 - V_L$$

4. Use the table below to determine the appropriate setting using the calculated  $V_{Drop}$  as a reference.

**INTERNAL RESISTANCE COMPENSATION**  
**TABLE**

Setting	$V_{Drop}$	Setting	$V_{Drop}$
2	11.44	17	1.34
3	7.60	18	1.27
4	5.72	19	1.20
5	4.57	20	1.14
6	3.81	21	1.09
7	3.27	22	1.04
8	2.86	23	0.99
9	2.54	24	0.95
10	2.28	25	0.91
11	2.08	26	0.88
12	1.90	27	0.85
13	1.76	28	0.82
14	1.63	29	0.79
15	1.52	30	0.76
16	1.43	31	0.74

**FUNCTION 15 BATTERY VOLTS**  
**(Push I5)**

This function allows for the adjustment of voltage range for controls equipped with the Battery Discharge Indication function. In order for the BDI to operate properly, the setting as shown in the table must be entered:

Battery Volts	Set Units
24 volts	Between 0 and 31
36 volts	Between 32 and 44
48 volts	Between 45 and 69
36/48 volts	Between 184 and 250
No BDI	Between 251 and 255

*The following functions have function numbers larger than the numbers on the Handset keyboard. To access these functions, push the CONT key and the number shown in the instructions at the same time. THE SEAT SWITCH MUST BE OPEN.*

**FUNCTION 16 PEDAL POSITION PLUG**  
**(Push CONT 1)**

This function will allow the adjustment of the pedal position plug range. Pedal position will reduce the plugging current to the current value set by this function as the accelerator is returned to the creep speed position. Maximum plug current is obtained with the accelerator in the top speed position.

Min	Max	Set	Resolution Per unit value	Example If set at 20
55	455	0 to 255	1.57 amps	86.4 amps

To disable the pedal position plug function, adjust this current value to the same current value as the plug distance current.

Example: If plug distance current, Function 5, is set at 350 amps, then set pedal plug current at 350 amps. With this setting, pedal position will have no effect on plugging distance.

*Note: Vehicles equipped with regenerative braking will vary the regen current with pedal position. However, minimum regen current is fixed at 50 amps. The pedal position will vary regen current between 50 amps and the maximum value of regen current set by Function 9.*

**FUNCTION 17 CARD TYPE SELECTION**  
**(Push CONT 2)**

This function allows for the selection of the card type used for your vehicle's application. The table below shows the setting to select card application type, depending on which control card is used. *Note that the right (slave) control for a dual motor proportioning system will be set differently than the left (master) control.*

*Note: Non-Auto Plug/Regen logic cards must be used for settings below:*

Functions	Standard	Regen
Std C/L	0 to 4	40 to 44
Std C/L (Right)	64 to 68	104 to 108
High C/L	5 to 9	45 to 49
High C/L (Right)	69 to 73	109 to 113

*Note: Auto Plug/Regen logic cards must be used for the settings below:*

Functions	Standard	Regen
Std C/L		
Auto Plug	10 to 14	50 to 54
Std C/L		
Auto Plug (Right)	74 to 68	114 to 118
High C/L		
Auto Plug	15 to 19	55 to 59
High C/L		
Auto Plug (Right)	79 to 83	119 to 123

Settings for these functions should be made within the ranges indicated above.

Warning: These settings must be changed by authorized personnel only, following instructions supplied by the vehicle manufacturer. Card type selection must be made within the capabilities of the control panel and the supporting electromechanical devices. Failure to comply with proper application standards could result in mis-operation or damage to the controls and/or motors.

**FUNCTION 18 STEER PUMP TIME DELAY**  
**( Push CONT 3 )**

This function allows for the selection of steer pump contactor pick up input, either seat switch or directional switch closing, and adjustment of the time delay for the contactor drop out.

- Pick up steer pump contactor on seat switch closure and time delay drop out of steer pump contactor on seat switch opening.

Range	1.5 to 65 seconds
Setting	Between 0 and 128
Resolution	0.5 seconds per set unit
Example	Setting of 20 = 11.5 seconds

**FUNCTION 19 MAINTENANCE CODE TENS AND UNITS HOURS SET**  
**( Push CONT 4 )**

This function allows for the adjustment of the tens and units hours of the maintenance code activation time.

Range	0 to 99
Set	0 to 99
Example	<u>99</u> 99 Hours

**FUNCTION 20 MAINTENANCE CODE THOUSANDS AND HUNDREDS HOURS SET**  
**( Push CONT 5 )**

This function allows for the adjustment of the tens and units hours of the maintenance code activation time.

Range	0 to 99
Set	0 to 99
Example	<u>99</u> 99 Hours

**FUNCTION 21 AUTO REGEN BRAKING C/L**  
**(Push CONT 6)**

This function allows for the adjustment of the Regen braking current limit. The higher the current the shorter the stopping distance.

Setting greater than 143 disables this function.

$$\text{AUTO REGEN C/L AMPS} = \text{REGEN C/L VAL} - \left[ \left( \frac{\text{FNT 21-51 VAL}}{\text{VAL}} \right) \times 3.25 \right]$$

**FUNCTION 23 REGEN CANCEL**  
**(Push CONT 8)**

Function adjusts the motor current for regen cancel.

Range:	52 - 260 amps
Setting:	0 to 255
Resolution:	.815 per set unit
Example:	Setting of 20 = (20*.815)+52 = 68.3

**FUNCTION 24 FIELD WEAKENING START**  
**(Push CONT 9)**

This function allows for setting the armature current at which minimum field current will be achieved.

Range	0 to 414 amps
Setting	0 to 255
Resolution	1.625 per set unit
Example	Setting of 20 = 32.5 amps

**FUNCTION 25 MONITOR**  
**( Push CONT 10 )**

This function allows the monitoring of certain control functions by looking directly at the RAM of the microprocessor. Because absolute memory locations need to be known, this function should not be used without detailed instructions from the GE application engineer.

*To ensure optimum operation of the control, this function must be left with zero stored in this register.*

**FUNCTION 26 RATIO**  
**( Push CONT 11 )**

This function sets the ratio between armature and field current when transitioning from minimum field to maximum field current. The setting represents the quantity of field current changed for each 1 amp of armature current above the armature current determined by setting of Function 24.

$$\text{FIELD CURRENT AMPS} = (\text{VALUE OF } \text{FUNCTION 26}) \times (\text{MOTOR CURRENT AMPS} - \text{VALUE OF } \text{FUNCTION 24}) \times .0074$$

**FUNCTION 28 STORED STATUS CODE COUNT POINTER**  
**( Push CONT 13 )**

This register contains the location of the last stored status code recorded of the 16 stored status codes. These stored status codes have caused a PMT controller shutdown and/or disruption of normal vehicle operation.

To determine which stored status code was the last one recorded, read the number stored in Function 28. Using the **Memory Map** for your logic card, match the "stored status

code pointer number" [the number shown in *(bold italics)* in the HS (Handset) number column] on the memory map, with the number obtained from Function 28. This will be the last stored status code recorded.

*Note: When scrolling through the stored status code register, the register always starts at status code 1 and scrolls to status code 16. Instructions for scrolling the register are in section 7.3.2 of this instruction booklet.*

**DASH DISPLAY INTERACTIVE MODES**

The following functions (Functions 48 through 62) are mode settings that are activated from the Interactive Dash Display. Each function must be set using the logic table shown below. If you try to set this function outside these guidelines, an error code will be displayed to prompt you to enter the correct setting:

- If "80" is displayed, the setting is too low.
- If "81" is displayed, the setting is too high.

**Note: The following functions have function numbers larger than the numbers on the Handset keyboard. To access these functions, push the CONT key and the number shown in the following instructions at the same time. The seat switch must be closed.**

**FUNCTION 48      MODE 1 (TURTLE) - ARMATURE CONTROLLED ACCELERATION AND 1A TIME (Push CONT 1)**

This function allows for the adjustment of the rate of time it takes for the control to accelerate to 100% applied battery voltage to the motor on hard acceleration. The 1A contactor will automatically close 0.2 seconds after the controlled acceleration stops and the accelerator input is less than 0.5 volts or less than 200 ohms.

Range	0.1 to 22.0 seconds
Set	0 to 255
Resolution	0.084 seconds per set unit
Example	Setting of 20 = 1.78 seconds C/A and 1.98 seconds 1A time

This C/A AND 1A TIME takes effect when the Mode 1 settings are called for by the Interactive Dash Display.

**FUNCTION 49      MODE 1 REGEN CURRENT LIMIT (Push CONT 2)**

Same as Function 9.

**FUNCTION 50      MODE 1 BRAKE PEDAL REGEN (Push CONT 3)**

Same as Function 21.

**FUNCTION 51      MODE 1 SPEED LIMIT 2 (Push CONT 4)**

Same as Function 12.

**FUNCTION 52      MODE 2 ARMATURE CONTROLLED ACCELERATION AND 1A TIME (Push CONT 5)**

Same as Function 48.

This C/A AND 1A TIME takes effect when the Mode 2 settings are called for by the Interactive Dash Display.

**FUNCTION 53      MODE 2 REGEN CURRENT LIMIT (Push CONT 6)**

Same as Function 49.

This FIELD WEAKENING START takes effect when the Mode 2 settings are called for by the Interactive Dash Display.

**FUNCTION 54      MODE 2 BRAKE PEDAL REGEN (Push CONT 7)**

Same as Function 50.

This MINIMUM FIELD CURRENT takes effect when the Mode 2 settings are called for by the Interactive Dash Display.

**FUNCTION 55      MODE 2 SPEED LIMIT 2 (Push CONT 8)**

Same as Function 51.

This RATIO takes effect when the Mode 2 settings are called for by the Interactive Dash Display.

**FUNCTION 56      MODE 3 ARMATURE CONTROLLED ACCELERATION AND 1A TIME (Push CONT 9)**

Same as Function 48.

This C/A AND 1A TIME takes effect when the Mode 3 settings are called for by the Interactive Dash Display.

**FUNCTION 57      MODE 3 REGEN CURRENT LIMIT**  
**(Push CONT 10)**

Same as Function 49.

This FIELD WEAKENING START takes effect when the Mode 3 settings are called for by the Interactive Dash Display.

**FUNCTION 58      MODE 3 BRAKE PEDAL REGEN**  
**(Push CONT 11)**

Same as Function 50.

This MINIMUM FIELD CURRENT takes effect when the Mode 3 settings are called for by the Interactive Dash Display.

**FUNCTION 59      MODE 3 SPEED LIMIT 2**  
**(Push CONT 12)**

Same as Function 51.

This RATIO takes effect when the Mode 3 settings are called for by the Interactive Dash Display.

**FUNCTION 60      MODE 4 ARMATURE CONTROLLED**  
**ACCELERATION AND 1A TIME**  
**(Push CONT 13)**

Same as Function 48.

This C/A AND 1A TIME takes effect when the Mode 4 settings are called for by the Interactive Dash Display.

**FUNCTION 61      MODE 4 REGEN CURRENT LIMIT**  
**(Push CONT 14)**

Same as Function 49.

This FIELD WEAKENING START takes effect when the Mode 4 settings are called for by the Interactive Dash Display.

**FUNCTION 62      MODE 4 BRAKE PEDAL REGEN**  
**(Push CONT 15)**

Same as Function 50.

This MINIMUM FIELD CURRENT takes effect when the Mode 4 settings are called for by the Interactive Dash Display.

**FUNCTION 63      MODE 4 SPEED LIMIT 2**  
**(Push CONT 16)**

Same as Function 51.

This RATIO takes effect when the Mode 4 settings are called for by the Interactive Dash Display.

Section 6.5 Summary of Current Limit Adjustments

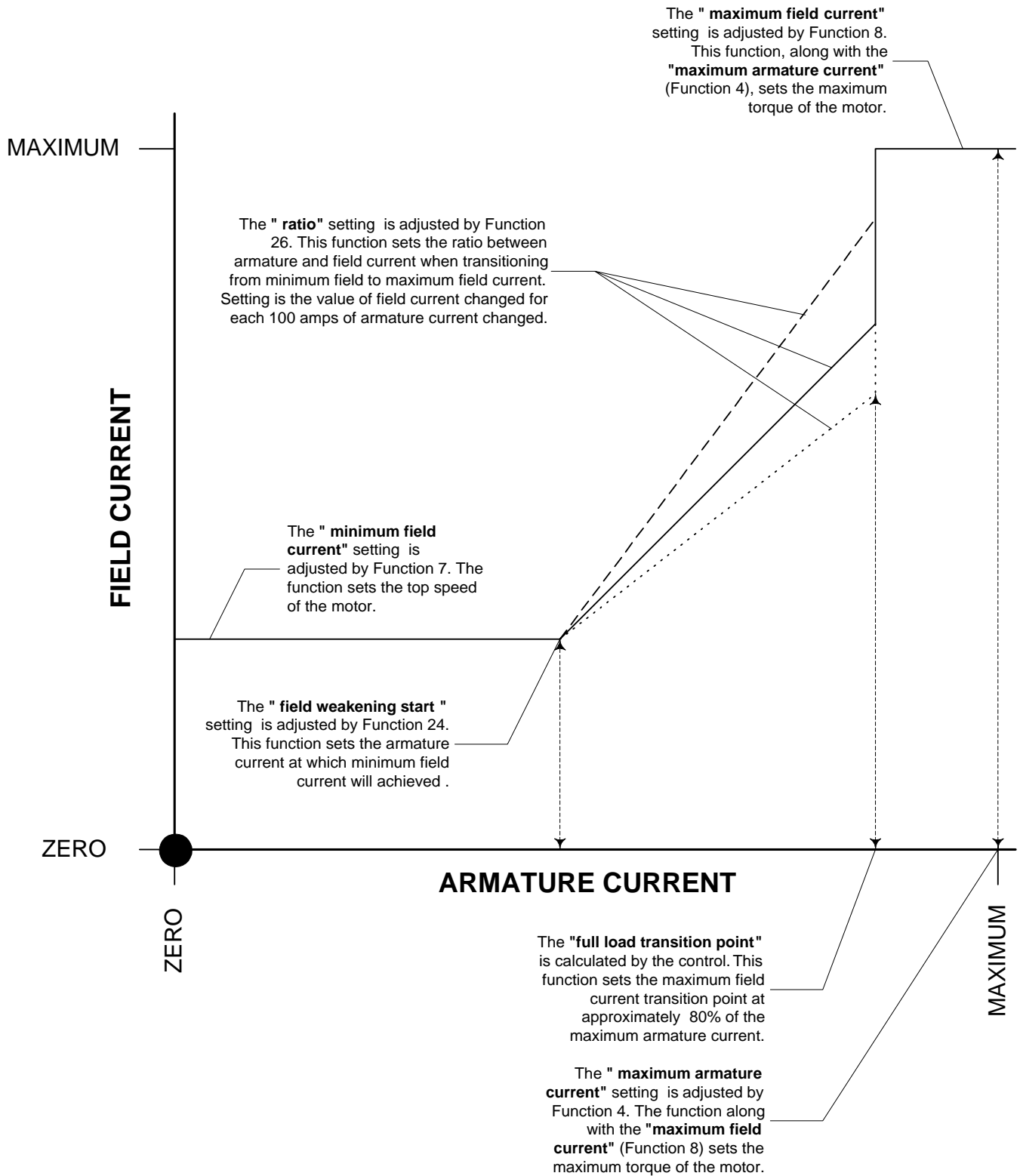

## Section 7. DASH DISPLAYS

### Section 7.1 Application

The SX family Standard and Interactive Dash Displays allow the operator and maintenance personnel easy access to truck operation information and real-time system diagnostics of the controller, motor and various accessories. Hourmeter readings, battery discharge information, maintenance information and system status codes are clearly displayed during startup and running modes. Shielded cable connections are made to the Dash Display by means of five (5) 22-gage wires to the "Y" Plug of the traction and hydraulic pump controls.

### Section 7.2 Standard Dash Displays

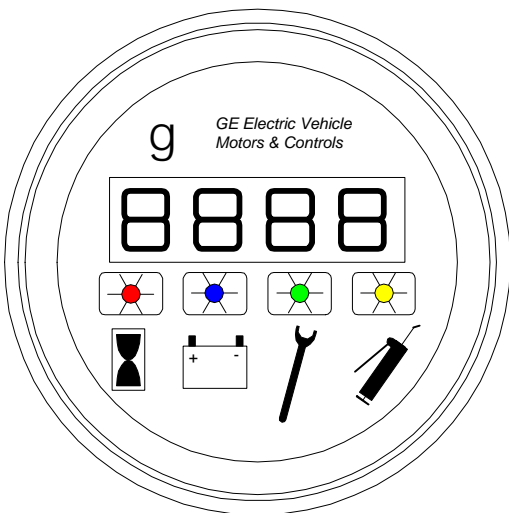

The GE Standard Dash Display is a four segment Light Emitting Diode (LED) instrument that displays the GE LX, ZX, and SX Status Codes, Hourmeter Readings, Battery Discharge Indication, and Maintenance Required Code. The four LED's above the symbols indicate the active readout mode.

### Section 7.3 Interactive Custom Dash Displays

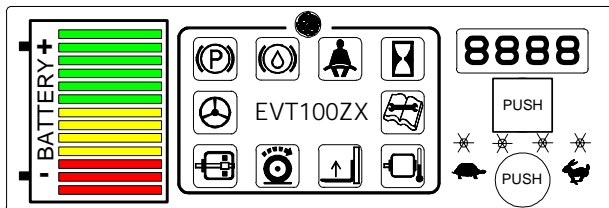

The Interactive Custom Dash Display allows the operator to select the best vehicle performance for changing factory (task) conditions. There are four (4) "operator interaction modes" that can be selected by depressing a push-button on the dash display.

From the Dash Display, the operator may select any of four pre-set interactive modes consisting of (4) Controlled Acceleration levels, (4) Field Weakening Pick Up levels and (4) Speed Limit levels.

These interactive modes are "pre-set" using the Handset (Functions 48 - 63) or a personal computer (Functions 97 - 112). This feature allows the operator to select the best vehicle performance for changing factory (task) conditions.

The Custom Dash Display incorporates all the features and functions of the Standard Dash Display, in addition to the following customer options:

- LED graphics to display Battery Discharge Indication status.
- Various LED indicators for Maintenance Required Status Codes. These can include options for traction, pump and power steer motors, hourmeter, over-temperature, seat belt, brake and other safety sensors.
- A push-button associated with the four segment LED that displays Status Codes can be used to scroll the last 16 "Stored Status Codes" that shut down vehicle operation with a PMT fault.

### CONNECTIONS

Connections are made to the Dash Display with five (5) 22-gage wires to Plug "Y" of each control. Shielded cable is required to eliminate signal interference.

### PART NUMBER

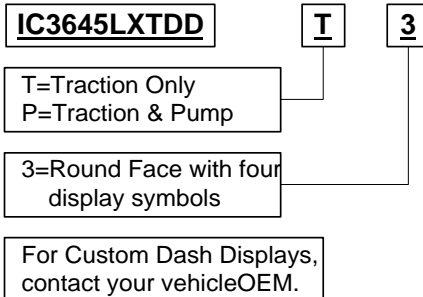

### REFERENCE

- AMP#102241-3 Dash Display mating plug
- AMP#1-87195-8 Dash Display mating pin
- 44A723596-G09 Dash Display plug kit
- AMP#175965-2 "Y" Plug
- AMP#175180-1 "Y" Plug receptacle

Section 7.4 Start-Up Display Sequence

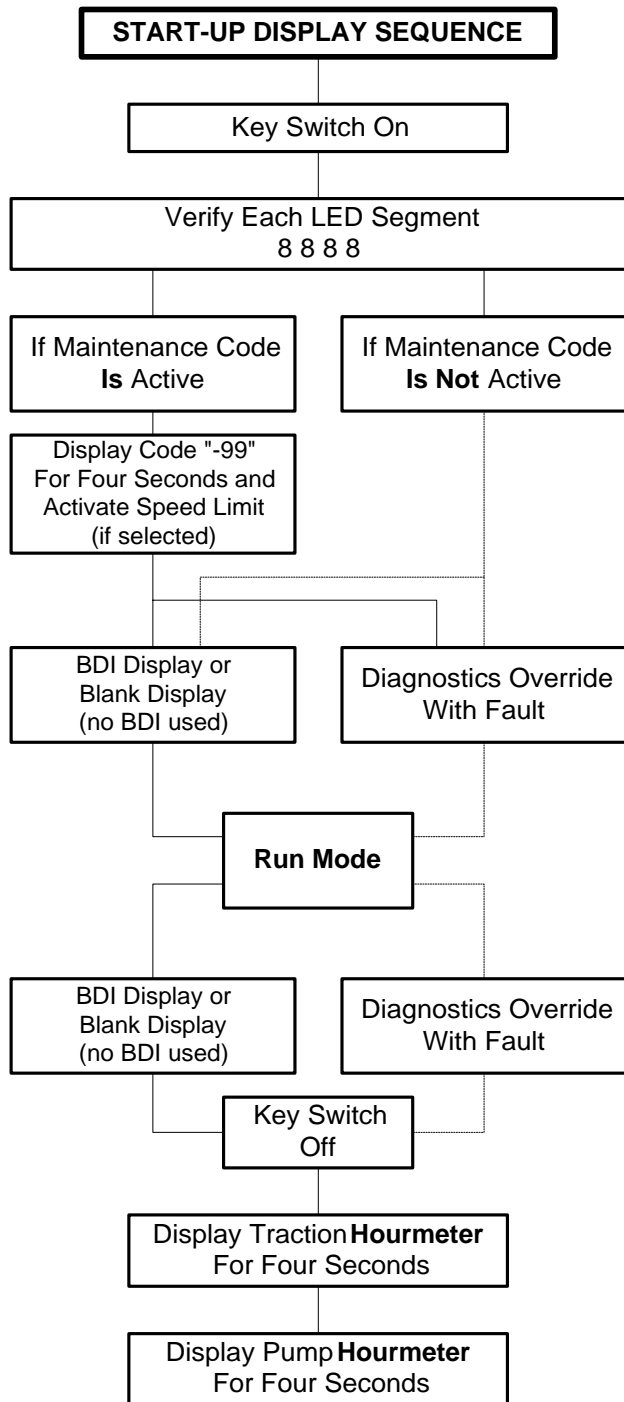

Section 7.5 Outline Drawings

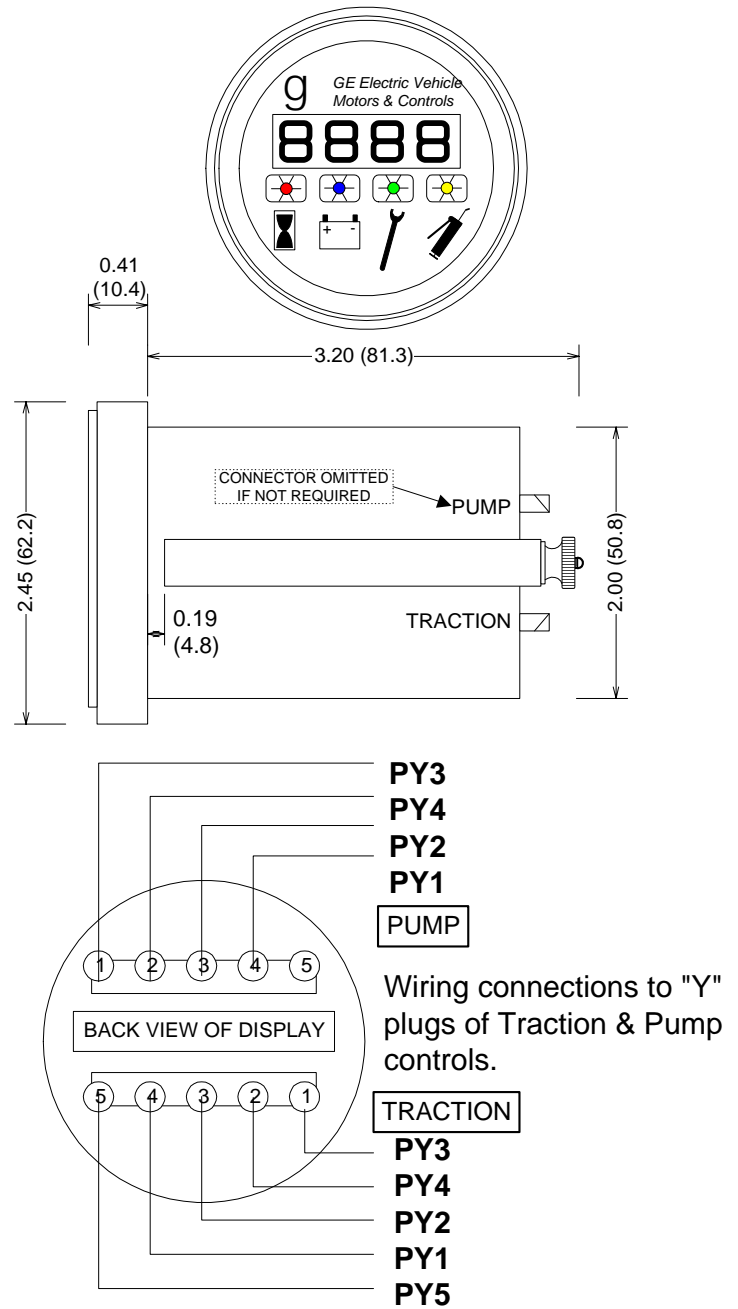

## Section 8.0 TURN ANGLE POTENTIOMETER INSTALLATION

## Section 8.1 GENERAL:

The potentiometer used for the turn angle must be a 270 degree rotation device that is attached to the steer wheel in a manner to cause a 1:1 rotation ratio between the two devices. Any ohm value potentiometer can be used, but it is suggested that it be at least 2KW or above, to keep the wattage of the potentiometer to a minimum. The turn angle potentiometer provides a voltage divider circuit that allows the left and right motor controller to determine the turn angle of the rear steer wheel of the vehicle. The potentiometer is connected to the two controls as show in Figure 1. After the potentiometer is installed on the vehicle, it will need to be adjusted to insure proper operation of the vehicle.

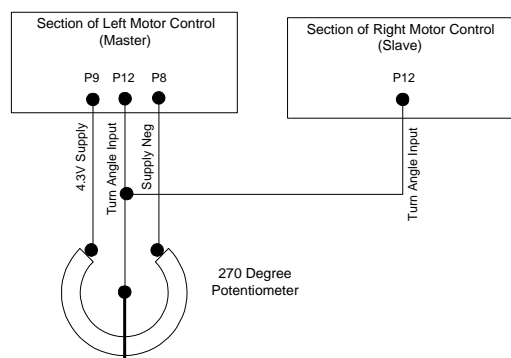

Figure 1

**OPERATION:**

To insure proper operation, the input voltage at P12 on both the left and right controls must coincide with the turn angle of the steer wheel. When the steer wheel is straight ahead ( Zero Degree Turn Angle), the input voltage at each control should be 2.15 volts. As the vehicle turns left, this input voltage will decrease, as the vehicle turns right, the input voltage will increase. The graph in Figure 2 outlines the input voltages, the actions of the controls and the corresponding turn angles of the steer wheel. A complete listing of input voltages, steer angles and control actions can be found in **Section 9.2 - 270 Degree Potentiometer Input**. As an example of control operation as compared to the input voltage, the following series of events takes place in a left turn from the zero to 90 degree steer wheel position. In the first 16° of

travel (2.15 to 1.90 volts), there is no change to inside wheel speed. Between 16° (1.90V) and 66° (1.10V), the inside motor will reduce its speed proportionally from top speed at 16° to creep speed at 66°. There will also be also available two vehicle speed limit enable points during the transition from 16° to 66°. Speed limit 1 can be enabled at 41° and speed limit 2 can be enabled at 60°. Between 66° and 71°, the inside wheel will be in a free wheel mode. As the steer reaches the 71° point, the inside wheel can now be programmed to reverse and accelerate proportionally in the opposite direction. Above 86° is over travel for the turn angle potentiometer.

**SETUP:**

**Before any adjustments are done. Jack up the drive wheels.**

Install the potentiometer on the vehicle steer wheel in such a way to allow adjustment of the shaft with the potentiometer and connected to both the left and right controls. Setup of the turn angle pot can be done in several ways, detailed below.

**Volt Meter Method:**

Attach a volt meter, positive to P12 and negative to P20. Insure that the steer wheel is pointing straight ahead (Zero Degree Angle); connect the battery and adjust the potentiometer until the voltage between P12 and P20 is 2.15 volts. Lock down the potentiometer shaft and turn the vehicle all the way to the left turn stop, the voltage should be .72 volts or less. Turn the wheel to the right turn stop, the voltage should be 3.53 volts or greater.

**Handset Monitor Mode Method:**

Plug the Handset into the left motor controller. Insure that the steer wheel is pointing straight ahead (Zero Degree Angle) and connect the battery. Place the Handset into the monitor routine ( Function 25 ) to view RAM location 95, which is turn angle volts, using the following steps:

1. Push CONT 10
2. Adjust Handset to 95
3. Push STORE
4. Angle Value Displayed
5. ESC to 8888 ( **To verify that you have the correct location** )
6. Push CONT 10
7. Display should read 95
8. Push STORE
9. Angle Value Displayed

Adjust the potentiometer until the Handset reads 110. Lock down the potentiometer shaft and turn the vehicle all the way to the left turn stop, the reading should be 37 or less. Turn the wheel to the right turn stop, the reading should be 183 or greater.

After adjusting the potentiometer, be sure to ESC out of the monitor routine and then reset Function 25 to zero using the same procedure as outlined above.

Section 8.2 270 Degree Potentiometer Input

## 270 DEGREE POTENTIOMETER FOR STEER ANGLE INPUT

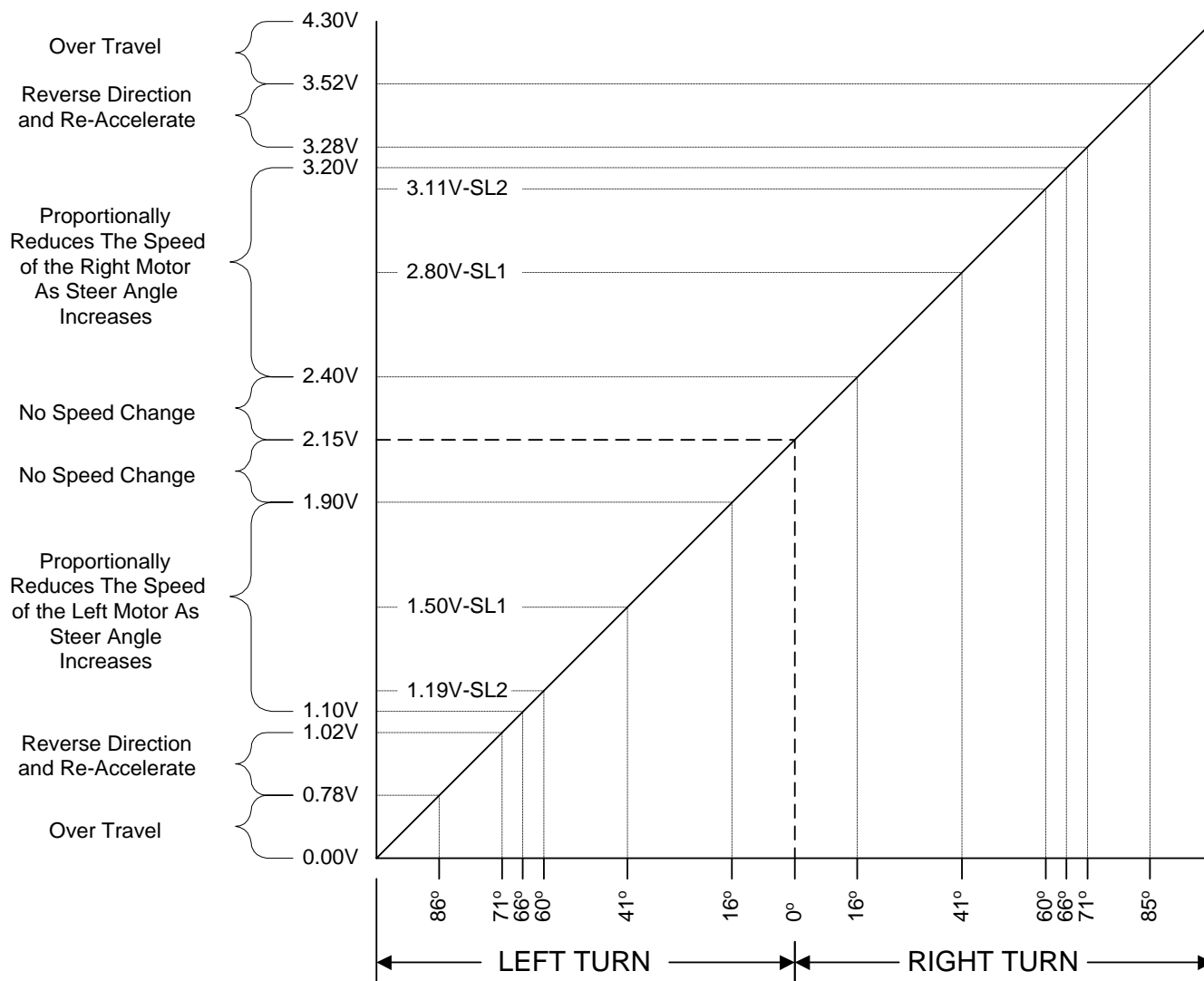

Figure 2

Section 8.3 Turn Angle Input Volts vs. Steer Wheel Degrees vs. Handset Readings

270 Degree Potentiometer	270 Degree Potentiometer
--------------------------	--------------------------

TURN ANGLE POTENTIOMETER INSTALLATION  
SX TRANSISTOR CONTROL

Left			Right			Actions	Left			Right			Actions
Volts	Deg	HS	Volts	Deg	HS		Volts	Deg	HS	Volts	Deg	HS	
2.15	Ctr	110	2.15	Ctr	110	No Change	1.42	46	72	2.88	46	147	Proportional Reduce
2.13	1	109	2.17	1	110	No Change	1.40	47	71	2.90	47	148	Proportional Reduce
2.12	2	108	2.18	2	111	No Change	1.39	48	71	2.91	48	149	Proportional Reduce
2.10	3	107	2.20	3	112	No Change	1.37	49	70	2.93	49	149	Proportional Reduce
2.09	4	106	2.21	4	113	No Change	1.35	50	69	2.95	50	150	Proportional Reduce
2.07	5	106	2.23	5	114	No Change	1.34	51	68	2.96	51	151	Proportional Reduce
2.05	6	105	2.25	6	115	No Change	1.32	52	67	2.98	52	152	Proportional Reduce
2.04	7	104	2.26	7	115	No Change	1.31	53	67	2.99	53	153	Proportional Reduce
2.02	8	103	2.28	8	116	No Change	1.29	54	66	3.01	54	154	Proportional Reduce
2.01	9	102	2.29	9	117	No Change	1.27	55	65	3.03	55	154	Proportional Reduce
1.99	10	102	2.31	10	118	No Change	1.26	56	64	3.04	56	155	Proportional Reduce
1.97	11	101	2.33	11	119	No Change	1.24	57	63	3.06	57	156	Proportional Reduce
1.96	12	100	2.34	12	119	No Change	1.23	58	63	3.07	58	157	Proportional Reduce
1.94	13	99	2.36	13	120	No Change	1.21	59	62	3.09	59	158	Proportional Reduce
1.93	14	98	2.37	14	121	No Change	<b>1.19</b>	<b>60</b>	<b>61</b>	<b>3.11</b>	<b>60</b>	<b>158</b>	<b>Speed Limit 2</b>
1.91	15	97	2.39	15	122	No Change	1.18	61	60	3.12	61	159	Proportional Reduce
<b>1.90</b>	<b>16</b>	<b>97</b>	<b>2.40</b>	<b>16</b>	<b>123</b>	<b>Top Speed Reduce</b>	1.16	62	59	3.14	62	160	Proportional Reduce
1.88	17	96	2.42	17	123	Proportional Reduce	1.15	63	58	3.15	63	161	Proportional Reduce
1.86	18	95	2.44	18	124	Proportional Reduce	1.13	64	58	3.17	64	162	Proportional Reduce
1.85	19	94	2.45	19	125	Proportional Reduce	1.11	65	57	3.19	65	162	Proportional Reduce
1.83	20	93	2.47	20	126	Proportional Reduce	<b>1.10</b>	<b>66</b>	<b>56</b>	<b>3.20</b>	<b>66</b>	<b>163</b>	<b>Creep Speed</b>
1.82	21	93	2.48	21	127	Proportional Reduce	1.08	67	55	3.22	67	164	Zero Speed
1.80	22	92	2.50	22	128	Proportional Reduce	1.07	68	54	3.23	68	165	Zero Speed
1.78	23	91	2.52	23	128	Proportional Reduce	1.05	69	54	3.25	69	166	Zero Speed
1.77	24	90	2.53	24	129	Proportional Reduce	1.04	70	53	3.26	70	167	Zero Speed
1.75	25	89	2.55	25	130	Proportional Reduce	<b>1.02</b>	<b>71</b>	<b>52</b>	<b>3.28</b>	<b>71</b>	<b>167</b>	<b>Reverse</b>
1.74	26	89	2.56	26	131	Proportional Reduce	1.00	72	51	3.30	72	168	Reverse
1.72	27	88	2.58	27	132	Proportional Reduce	0.99	73	50	3.31	73	169	Reverse
1.70	28	87	2.60	28	132	Proportional Reduce	0.97	74	50	3.33	74	170	Reverse
1.69	29	86	2.61	29	133	Proportional Reduce	0.96	75	49	3.34	75	171	Reverse
1.67	30	85	2.63	30	134	Proportional Reduce	0.94	76	48	3.36	76	171	Reverse
1.66	31	84	2.64	31	135	Proportional Reduce	0.92	77	47	3.38	77	172	Reverse
1.64	32	84	2.66	32	136	Proportional Reduce	0.91	78	46	3.39	78	173	Reverse
1.62	33	83	2.68	33	136	Proportional Reduce	0.89	79	45	3.41	79	174	Reverse
1.61	34	82	2.69	34	137	Proportional Reduce	0.88	80	45	3.42	80	175	Reverse
1.59	35	81	2.71	35	138	Proportional Reduce	0.86	81	44	3.44	81	175	Reverse
1.58	36	80	2.72	36	139	Proportional Reduce	0.84	82	43	3.46	82	176	Reverse
1.56	37	80	2.74	37	140	Proportional Reduce	0.83	83	42	3.47	83	177	Reverse
1.54	38	79	2.76	38	141	Proportional Reduce	0.81	84	41	3.49	84	178	Reverse
1.53	39	78	2.77	39	141	Proportional Reduce	0.80	85	41	3.50	85	179	Reverse
1.51	40	77	2.79	40	142	Proportional Reduce	<b>0.78</b>	<b>86</b>	<b>40</b>	<b>3.52</b>	<b>86</b>	<b>180</b>	<b>Reverse</b>
<b>1.50</b>	<b>41</b>	<b>76</b>	<b>2.80</b>	<b>41</b>	<b>143</b>	<b>Speed Limit 1</b>	0.76	87	39	3.54	87	180	Over Travel
1.48	42	76	2.82	42	144	Proportional Reduce	0.75	88	38	3.55	88	181	Over Travel
1.47	43	75	2.83	43	145	Proportional Reduce	0.73	89	37	3.57	89	182	Over Travel
1.45	44	74	2.85	44	145	Proportional Reduce	0.72	90	37	3.58	90	183	Over Travel
1.43	45	73	2.87	45	146	Proportional Reduce							

Section 9.0 Memory Maps

Section 9.1 Typical Memory Map for Dual Motor Proportioning Controls

E <sup>2</sup>	Func No.	HS No.	Traction Control Function	Access By	Restrictions
0	1	1	MPH Scaling	HS or PC	None
1	2	2	Creep	HS or PC	None
2	3	3	Controlled Acceleration	HS or PC	None
3	4	4	Armature Current Limit	HS or PC	None
4	5	5	Plug Current Limit	HS or PC	None
5	6	6	1A Dropout	HS or PC	None
6	7	7	Minimum Field Current	HS or PC	None
7	8	8	Maximum Field Current	HS or PC	None
8	9	9	Regen Current Limit	HS or PC	None
9	10	10	Regen & Plug Max Fld Current	HS or PC	None
10	11	11	Speed Limit 1	HS or PC	None
11	12	12	Speed Limit 2	HS or PC	None
12	13	13	Speed Limit 3 and VMM	HS or PC	None
13	14	14	IR Compensation	HS or PC	None
14	15	15	Battery Volts Select	HS or PC	None
15	16	16	Pedal Position Plug	HS or PC	None
16	17	17	Card Type Select	HS or PC	None
17	18	18	Seat Time Delay	HS or PC	None
18	19	19	HM (Tens/Units)	HS or PC	None
19	20	20	HM (Thou/Hun)	HS or PC	None
20	21	21	Auto Regen	HS or PC	None
21	22	22	Mode Reference	HS or PC	For DD on power up
22	23	23	Field PWM Gain	HS or PC	None
23	24	24	FW Start	HS or PC	None
24	25	25	Monitor	HS or PC	GE Temporary Storage
25	26	26	Ratio	HS or PC	GE Temporary Storage
26	27	27	HM Minutes	HS or PC	GE Temporary Storage
27	28	28	Fault Count Pointer	HS or PC	None
28	29	29	Aux HM (Tens/Ones) Adj	HS or PC	None
29	30	30	Aux HM (Thou/Hun) Adj	HS or PC	None
30	31		Aux HM (Tens/Ones)	PC Only	None
31	32		Aux HM (Thou/Hun)	PC Only	None
32	33	(18)	Stored Status Code #1	PC Only	Reset to Zero Only
33	34		BDI 1	PC Only	Reset to Zero Only
34	35		Hours (Tens/Ones) 1	PC Only	Reset to Zero Only
35	36		Hours (Thou/Hun) 1	PC Only	Reset to Zero Only
36	37	(20)	Stored Status Code #2	PC Only	Reset to Zero Only
37	38		BDI 2	PC Only	Reset to Zero Only
38	39		Hours (Tens/Ones) 2	PC Only	Reset to Zero Only
39	40		Hours (Thou/Hun) 2	PC Only	Reset to Zero Only
40	41	(22)	Stored Status Code #3	PC Only	Reset to Zero Only
41	42		BDI 3	PC Only	Reset to Zero Only
42	43		Hours (Tens/Ones) 3	PC Only	Reset to Zero Only
43	44		Hours (Thou/Hun) 3	PC Only	Reset to Zero Only

E <sup>2</sup>	Func No.	HS No.	Traction Control Function	Access By	Restrictions
45	46		BDI 4	PC Only	Reset to Zero Only
46	47		Hours (Tens/Ones) 4	PC Only	Reset to Zero Only
47	48		Hours (Thou/Hun) 4	PC Only	Reset to Zero Only
48	49	(26)	Stored Status Code #5	PC Only	Reset to Zero Only
49	50		BDI 5	PC Only	Reset to Zero Only
50	51		Hours (Tens/Ones) 5	PC Only	Reset to Zero Only
51	52		Hours (Thou/Hun) 5	PC Only	Reset to Zero Only
52	53	(28)	Stored Status Code #6	PC Only	Reset to Zero Only
53	54		BDI 6	PC Only	Reset to Zero Only
54	55		Hours(Tens/Ones) 6	PC Only	Reset to Zero Only
55	56		Hours(Thou/Hun) 6	PC Only	Reset to Zero Only
56	57	(30)	Stored Status Code #7	PC Only	Reset to Zero Only
57	58		BDI 7	PC Only	Reset to Zero Only
58	59		Hours(Tens/Ones) 7	PC Only	Reset to Zero Only
59	60		Hours(Thou/Hun) 7	PC Only	Reset to Zero Only
60	61	(32)	Stored Status Code #8	PC Only	Reset to Zero Only
61	62		BDI 8	PC Only	Reset to Zero Only
62	63		Hours;(Tens/Ones) 8	PC Only	Reset to Zero Only
63	64		Hours(Thou/Hun) 8	PC Only	Reset to Zero Only
64	65	(34)	Stored Status Code #9	PC Only	Reset to Zero Only
65	66		BDI 9	PC Only	Reset to Zero Only
66	67		Hours(Tens/Ones) 9	PC Only	Reset to Zero Only
67	68		Hours(Thou/Hun) 9	PC Only	Reset to Zero Only
68	69	(36)	Stored Status Code #10	PC Only	Reset to Zero Only
69	70		BDI 10	PC Only	Reset to Zero Only
70	71		Hours(Tens/Ones) 10	PC Only	Reset to Zero Only
71	72		Hours(Thou/Hun) 10	PC Only	Reset to Zero Only
72	73	(38)	Stored Status Code #11	PC Only	Reset to Zero Only
73	74		BDI 11	PC Only	Reset to Zero Only
74	75		Hours(Tens/Ones) 11	PC Only	Reset to Zero Only
75	76		Hours(Thou/Hun) 11	PC Only	Reset to Zero Only
76	77	(40)	Stored Status Code #12	PC Only	Reset to Zero Only
77	78		BDI 12	PC Only	Reset to Zero Only
78	79		Hours(Tens/Ones) 12	PC Only	Reset to Zero Only
79	80		Hours(Thou/Hun) 12	PC Only	Reset to Zero Only
80	81	(42)	Stored Status Code #13	PC Only	Reset to Zero Only
81	82		BDI 13	PC Only	Reset to Zero Only
82	83		Hours(Tens/Ones) 13	PC Only	Reset to Zero Only
83	84		Hours(Thou/Hun) 13	PC Only	Reset to Zero Only
84	85	(44)	Stored Status Code # 14	PC Only	Reset to Zero Only
85	86		BDI 14	PC Only	Reset to Zero Only
86	87		Hours(Tens/Ones) 14	PC Only	Reset to Zero Only
87	88		Hours(Thou/Hun) 14	PC Only	Reset to Zero Only
88	89	(46)	Stored Status Code # 15	PC Only	Reset to Zero Only
89	90		BDI 15	PC Only	Reset to Zero Only
90	91		Hours (Tens/Ones) 15	PC Only	Reset to Zero Only
91	92		Hours (Thou/Hun) 15	PC Only	Reset to Zero Only

E <sup>2</sup>	Func No.	HS No.	Traction Control Function	Access By	Restrictions
92	93	<b>(48)</b>	Stored Status Code #16	PC Only	Reset to Zero Only
94	95		Hours (Tens/Ones) 16	PC Only	Reset to Zero Only
95	96		Hours (Thou/Hun) 16	PC Only	Reset to Zero Only
96	67	48	Dash Display CA-1		
97	98	49	Dash Display FWS-1/Ratio2-1	HS or PC	None
98	99	50	Dash Display Min Fld-1	HS or PC	None
99	100	51	Dash Display If/Im Ratio-1/ SL-1	HS or PC	None
100	101	52	Dash Display CA-2	HS or PC	None
101	102	53	Dash Display FWS-2/Ratio2-2	HS or PC	None
102	103	54	Dash Display Min Fld-2	HS or PC	None
103	104	55	Dash Display If/Im Ratio-2/ SL-2	HS or PC	None
104	105	56	Dash Display CA-3	HS or PC	None
105	106	57	Dash Display FWS-3/Ratio2-3	HS or PC	None
106	107	58	Dash Display Min Fld-3	HS or PC	None
107	108	59	Dash Display If/Im Ratio-3/ SL-3	HS or PC	None
108	109	60	Dash Display CA-4	HS or PC	None
109	110	61	Dash Display FWS-4/Ratio2-4	HS or PC	None
110	111	62	Dash Display Min Fld-4	HS or PC	None
111	112	63	Dash Display If/Im Ratio-4/ SL-4	HS or PC	None
112	113		Secure HM (Tens/Ones)	PC Only	OEM Read Only
113	114		Secure HM (Thou/Hun)	PC Only	OEM Read Only
114	115		Secure Aux HM (Tens/Ones)	PC Only	OEM Read Only
115	116		Secure Aux HM (Thou/Hun)	PC Only	OEM Read Only
116	117		Reserved	PC Only	GE Future Use
117	118		Reserved	PC Only	GE Future Use
118	119		Reserved	PC Only	GE Future Use
119	120		Reserved	PC Only	GE Future Use
120	121		OEM Use	PC Only	None
121	122		OEM Use	PC Only	None
122	123		OEM Use	PC Only	None
123	124		OEM Use	PC Only	None
124	125		OEM Use	PC Only	None
125	126		OEM Use	PC Only	None
126	127		OEM Use	PC Only	None
127	128		OEM Use	PC Only	None

Numbers in ***(bold italics)*** are Stored Status Code pointers.