

SEPARATELY EXCITED (SX) TRANSISTORIZED MOTOR CONTROLLERS  
FOR CENTER RIDE/TUGGER APPLICATION

(GE MODEL IC3645SR2R404F5)

INSTALLATION AND OPERATION MANUAL

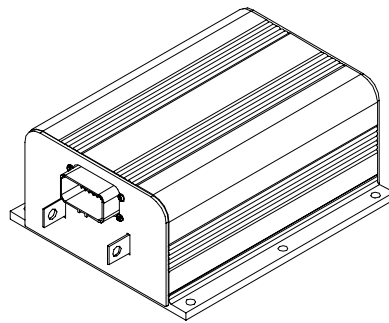

*Note: The information contained herein is intended to assist OEM's, Dealers and Users of electric vehicles in the application, installation and service of GE solid-state controllers. This manual does not purport to cover all variations in OEM vehicle types. Nor does it provide for every possible contingency to be met involving vehicle installation, operation or maintenance. For additional information and/or problem resolution, please refer the matter to the OEM vehicle manufacturer through his normal field service channels. Do not contact GE directly for this assistance.*

Table of Contents

General Electric Company February 2002

<b>Section 1.0</b>	<b>INTRODUCTION .....</b>	<b>4</b>
1.1	Motor Characteristics .....	4
1.2	Solid-State Reversing .....	5
1.3	Flexible System Application.....	5
1.4	More Features with Fewer Components .....	5
<b>Section 2.0</b>	<b>FEATURES OF SX FAMILY OF MOTOR CONTROLLERS .....</b>	<b>5</b>
2.1	Performance .....	5
2.1.1	Oscillator Card Features .....	5
2.1.1.a	Standard Operation .....	5
2.1.1.b	Control Acceleration.....	6
2.1.2	Current Limit .....	6
2.1.3	Braking .....	6
2.1.3.a	Plug Braking .....	6
2.1.3.b	Regenerative Braking to Zero Speed .....	6
2.1.3.c	Throttle Position Plug Braking.....	6
2.1.4	Auxiliary Speed Control.....	6
2.1.4.a	Field Weakening.....	6
2.1.4.b	Speed Limits .....	6
2.1.5	Ramp Operation .....	7
2.1.5.a	Ramp Start .....	7
2.1.5.b	Anti-Rollback .....	7

**Table of Contents ( Continued )**

2.1.6	On-Board Coil Drivers and Internal Coil Suppression .....	7
2.2	System Protective Override .....	7
2.2.1	Static Return to Off (SRO) .....	7
2.2.2	Accelerator Volts Hold Off .....	7
2.2.3	Pulse Monitor Trip (PMT).....	7
2.2.4	Thermal Protector (TP).....	7
2.2.5	Low Voltage Detection.....	7
2.3	Diagnostics.....	7
2.3.1	Status Codes.....	7
2.3.1.a	Standard Status Codes.....	7
2.3.1.b	Stored Status Codes .....	8
2.3.2	Hourmeter Readings .....	8
2.3.2.a	Maintenance Alert Status Code .....	8
2.3.3	Battery Discharge Indication (BDI).....	8
2.3.3.a	Internal Resistance Compensation .....	8
2.3.4	Handset .....	8
2.3.5	Circuit Board Coil Driver Modules.....	8
2.3.6	Selectable Truck Modes .....	8
<b>Section 3.0</b>	<b>ORDERING INFORMATION, ELEMENTARY AND OUTLINE DRAWINGS.....</b>	<b>9</b>
3.1	Ordering Information for Separately Excited Controls.....	9
3.2	Outline: SX-2 Package Size.....	10
3.3	Standard Elementary for Center Ride Application.....	11
3.4	Standard Elementary for Tugger Application .....	12
3.4	Standard Center Ride/Tugger Application Input / Output List.....	13
<b>Section 4.0</b>	<b>TROUBLESHOOTING AND DIAGNOSTIC STATUS CODES.....</b>	<b>14</b>
4.1	General Maintenance Instructions.....	14
4.2	Cable Routing and Separation .....	14
4.2.1	Application Responsibility .....	14
4.2.2	Signal/Power Level Definitions .....	14
4.2.2.a	Low Level Signals (Level L) .....	14
4.2.2.b	High Level Signals (Level H).....	15
4.2.2.c	Medium-Power Signals (Level MP) .....	15
4.2.2.d	High-Power Signals (Level HP) .....	15
4.2.3	Cable Spacing Guidelines .....	15
4.2.3.a	General Cable Spacing.....	15
4.2.4	Cabling for Vehicle Retrofits.....	15
4.2.5	RF Interference.....	15
4.2.6	Suppression.....	15
4.3	Recommended Lubrication of Pins and Sockets Prior to Installation.....	16
4.4	Controller Mounting Guidelines .....	17
4.4.1	Necessary Tools .....	17
4.4.2	The GE Control Mounting Surface.....	17
4.4.3	Vehicle Mounting Surface .....	17
4.4.4	Application of Thermal Compound .....	17
4.4.5	Mounting the GE Control.....	18
4.4.6	Maintenance .....	18
4.5	General Troubleshooting Instructions .....	18
4.6	Traction Controller Status Codes .....	20-33

**Table of Contents ( Continued )**

<b>Section 5.0</b>	<b>SX FAMILY - GE HANDSET INSTRUCTIONS .....</b>	<b>34</b>
5.1	General Features .....	34
5.2	Purpose/Setup Functions .....	34
5.3	Setup Function Procedures .....	35
5.3.1	Setup Mode .....	35
5.3.2	Status Code Scrolling.....	35
5.3.3	SX Handset Plug Connections & Outline Drawing.....	35
5.4	Setup Functions for Traction Controller ..	36-41
5.5	Summary of Current Limit Adjustments .....	42
<b>Section 6.0</b>	<b>DASH DISPLAYS.....</b>	<b>43</b>
6.1	Application .....	43
6.2	Standard Dash Displays .....	43
6.2.1	Connections.....	43
6.2.2	Part Numbers .....	44
6.2.3	Connector Reference Numbers.....	44
6.3	Start-up Display Sequence .....	44
6.4	Outline Drawings .....	44
<b>Section 7.0</b>	<b>MEMORY MAPS.....</b>	<b>45</b>
7.1	Typical Memory Map for Traction Control.....	45-47

**Section 1. INTRODUCTION**

**Section 1.1 Motor Characteristics**

The level of sophistication in the controllability of traction motors has changed greatly over the past several years. Vehicle manufacturers and users are continuing to expect more value and flexibility in electric vehicle motor and control systems as they are applied today. In order to respond to these market demands, traction system designers have been forced to develop new approaches to reduce cost and improve functions and features of the overall system. Development is being done in a multi-generational format that allows the market to take advantage of today's technology, while looking forward to new advances on the horizon. GE has introduced a second generation system using separately excited DC shunt wound motors. The separately excited DC motor system offers many of the features that are generally found on the advanced AC systems. Historically, most electric vehicles have relied on series motor designs because of their ability to produce very high levels of torque at low speeds. But, as the demand for high efficiency systems increases, i.e., systems that are more closely applied to customers' specific torque requirements, shunt motors are now often being considered over series motors. In most applications, by independently controlling the field and armature currents in the separately excited motor, the best attributes of both the series and the shunt wound motors can be combined.

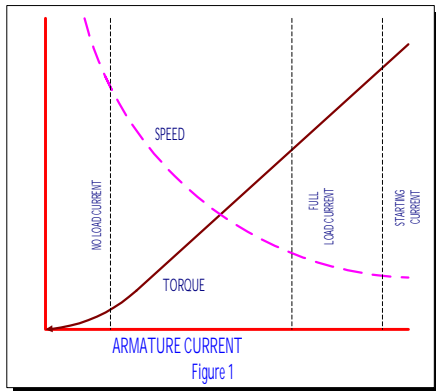

As shown in the typical performance curves of Figure 1, the high torque at low speed characteristic of the series motor is evident.

In a shunt motor, the field is connected directly across the voltage source and is therefore independent of variations in load and armature current. If field strength is held constant, the torque developed will vary directly with the armature current. If the mechanical load on the motor increases, the motor slows down, reducing the back EMF (which depends on the speed, as well as the constant field strength). The reduced back EMF allows the armature

current to increase, providing the greater torque needed to drive the increased mechanical load. If the mechanical load is decreased, the process reverses. The motor speed and the back EMF increase, while the armature current and the torque developed decrease. Thus, whenever the load changes, the speed changes also, until the motor is again in electrical balance.

In a shunt motor, the variation of speed from no load to normal full load on level ground is less than 10%. For this reason, shunt motors are considered to be constant speed motors (Figure 2).

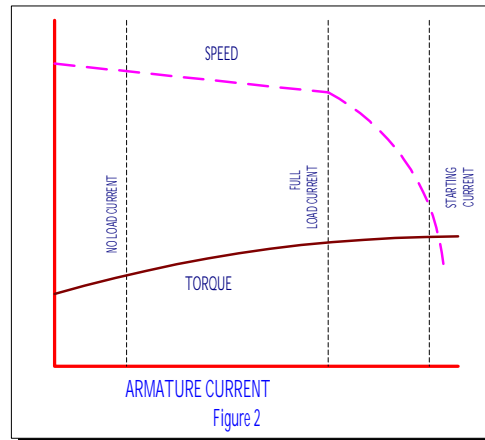

In the separately excited motor, the motor is operated as a fixed field shunt motor in the normal running range. However, when additional torque is required, for example, to climb non-level terrain, such as ramps and the like, the field current is increased to provide the higher level of torque. In most cases, the armature to field ampere turn ratio can be very similar to that of a comparable size series motor (Figure 3.)

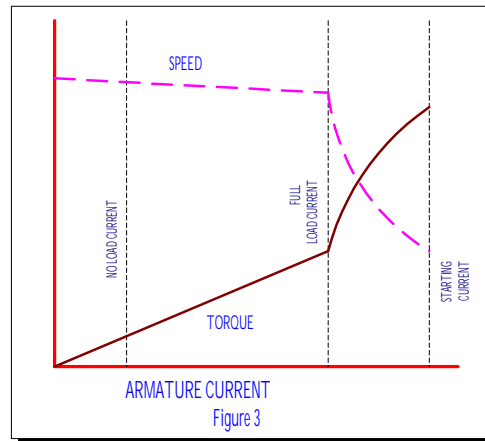

Aside from the constant horsepower characteristics described above, there are many other features that provide increased performance and lower cost. The following description provides a brief introduction to some of these features.

**Section 1. 2 Solid-State Reversing**

The direction of armature rotation on a shunt motor is determined by the direction in which current flows through the field windings. Because of the shunt motor field, typically only requires about 10% of the armature current at full torque, it is normally cost effective to replace the double-pole, double-throw reversing contactor with a low power transistor H-Bridge circuit (Figure 4).

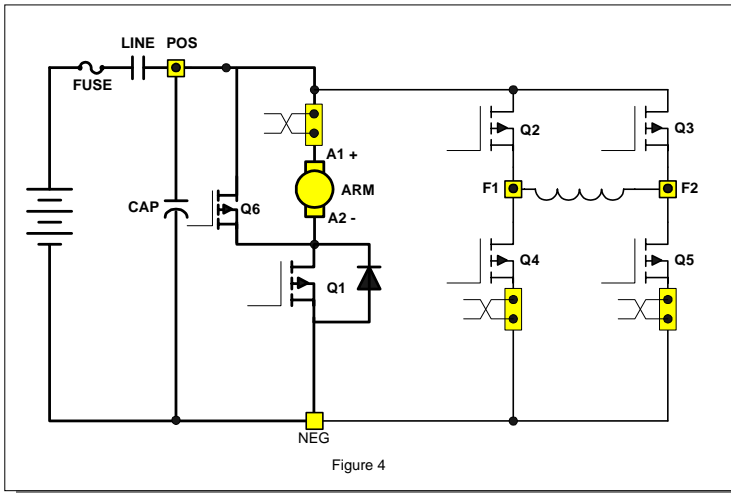

Figure 4

By energizing the transistors in pairs, current can be made to flow in either direction in the field. The field and armature control circuits typically operate at 12KHZ to 15KHZ, a frequency range normally above human hearing. This high frequency, coupled with the elimination of directional contactors, provides for very quiet vehicle operation.

The line contactor is normally the only contactor required for the shunt motor traction circuit. This contactor is used for both pre-charge of the line capacitors and for emergency shut down of the motor circuit, in case of problems that would cause a full motor torque condition. The line can be energized and de-energized by the various logic combinations of the vehicle, i.e. activate on key, seat or start switch closure, and de-energize on time out of idle vehicle. Again, these options add to the quiet operation of the vehicle.

**Section 1. 3 Flexible System Application**

Because the shunt motor controller has the ability to control both the armature and field circuits independently, the system can normally be adjusted for maximum system efficiencies at certain operating parameters. Generally speaking, with the ability to independently control the field and armature, the motor performance curve can be maximized through proper control application.

**Section 1. 4 More Features with Fewer Components**

Field weakening with a series wound motor is accomplished by placing a resistor in parallel with the field winding of the motor. Bypassing some of the current flowing in the field into the resistor causes the field current to be less, or weakened. With the field weakened, the motor speed will increase, giving the effect of "overdrive". To change the "overdrive speed", it is necessary to change the resistor value. In a separately excited motor, independent control of the field current provides for infinite adjustments of "overdrive" levels, between the motor base speed and maximum weak field. The desirability of this feature is enhanced by the elimination of the contactor and resistor required for field weakening with a series motor.

With a separately excited motor, overhauling speed limit, or downhill speed, will also be more constant. By its nature, the shunt motor will try to maintain a constant speed downhill. This characteristic can be enhanced by increasing the field strength with the control. Overhauling load control works in just the opposite way of field weakening, as armature rotation slows with the increase of current in the field. An extension of this feature is a zero-speed detect feature which prevents the vehicle from free-wheeling down an incline, should the operator neglect to set the brake.

Regenerative braking (braking energy returned to the battery) may be accomplished completely with solid-state technology. The main advantage of regenerative braking is increased motor life. Motor current is reduced by 50% or better during braking while maintaining the same braking torque as electrical braking with a diode clamp around the armature. The lower current translates into longer brush life and reduced motor heating. Solid state regenerative braking also eliminates a power diode, current sensor and contactor from the circuit.

For GE, the future is now, as we make available a new generation of electric traction motor systems for electric vehicles having separately excited DC shunt motors and controls. Features that were once thought to be only available on future AC or brushless DC technology vehicles systems are now achievable and affordable.

**Section 2. FEATURES OF SX FAMILY OF TRANSISTOR MOTOR CONTROLLERS**

**Section 2.1 Performance**

**Section 2.1.1 Oscillator Card Features**

**Section 2.1.1.a Standard Operation**

The oscillator section of the card has two adjustable features, creep speed and minimum field current. With the accelerator at maximum ohms or volts, the creep speed can be adjusted by Function 2 of the Handset or a trimpot. The field control section allows the adjustment of the field weakening level in order to set the top speed of the motor. This top speed function (Minimum Field Current) is enabled when the armature current is less than the value set by Function 24 and the accelerator input voltage is less than 1 volt. Top Speed can be adjusted by Function 7 of the Handset or a trimpot.

The % ON-time has a range of approximately 0 to 100 percent. The SX controllers operate at a constant frequency and the % ON-time is controlled by the pulse width of the voltage/current applied to the motor circuits.

### Section 2.1.1.b Control Acceleration

This feature allows for adjustment of the rate of time it takes for the control to accelerate to 100% applied battery voltage to the motor on hard acceleration. Armature C/A is adjusted by Function 3 from 0.1 to 6 seconds.

### Section 2.1.2 Current Limit

This circuit monitors motor current by utilizing sensors in series with the armature and field windings. The information detected by the sensor is fed back to the card so that current may be limited to a preset value. If heavy load currents are detected, this circuit overrides the oscillator and limits the average current to a value set by Function 4 and Function 8 of the Handset. The C/L setting is based on the maximum thermal rating of the control. Because of the flyback current through Q6, the motor current is usually greater than battery current, except at 100% ON time.

### Section 2.1.3 Braking

#### Section 2.1.3.a Plug Braking

Slow down is accomplished when reversing direction by providing a small amount of retarding torque for deceleration. If the vehicle is moving, and the directional lever is moved from one direction to the other, the plug signal is initiated. Once the plug signal has been initiated, the field is reversed, and the armature current is regulated to the plug current limit as set by Function 5. Armature current is regulated by increasing the field current as the vehicle slows down. Once the field current reaches a preset value, set by Function 10, and armature plug current can no longer be maintained, the braking function is canceled, and the control reverts back to motoring. All energy produced by the motor during plugging is dumped as heat into the motor in this braking mode.

#### Section 2.1.3.b Regenerative Braking to Zero Speed

Slow down is accomplished when reversing direction by providing a small amount of retarding torque for deceleration. If the vehicle is moving, and the directional lever is moved from one direction to the other, the regen signal is initiated. Once the regen signal has been initiated, the field current is increased. Armature current is regulated to the regen current limit as set by Function 9. As the vehicle slows down, the field current continues to increase, and transistor Q2 begins to chop. The field current will increase until it reaches a preset value set by Function 10, and transistor Q2 on-time will increase until it reaches 100% on-time. Once both of the above conditions have been met, and the regen current limit can no longer be maintained, the braking function is canceled. The fields will then reverse, and the control reverts back to motoring.

Part of the energy produced by the motor during regen is returned to the battery, and the remainder is dumped into the motor as heat.

#### Section 2.1.3.c Throttle Position Plug Braking

This feature allows control of the plugging distance based on throttle position when there has been a "directional switch" change. Throttle position will reduce the plugging current as the throttle is returned to the creep speed position. Maximum plug current is obtained with the accelerator in the top speed position.

### Section 2.1.4 Field Weakening

This function allows the adjustment of the field weakening level in order to set the top speed of the motor. The function is enabled when the armature current is less than the value set by Function 24. It is important to note that this function is used to optimize motor and control performance, and this setting will be determined by GE and OEM engineers at the time of vehicle development. *This setting must not be changed by field personnel without the permission of the OEM.*

### Section 2.1.5 Ramp Operation

#### Section 2.1.5.a Ramp Start

This feature provides maximum control torque to restart a vehicle on an incline. The memory for this function is the directional switch. When stopping on an incline, the directional switch must be left in its original or neutral position to allow the control to initiate full power when restarted. The accelerator potentiometer input will modulate ramp start current.

### Section 2.1.5.b Anti-Rollback

This feature provides retarding torque to limit rollback speed in the non-travel direction when the ACC pedal is released when stopping on a grade, or when the brake pedal is released when starting on a grade. This feature forces the vehicle to roll very slowly down the grade when the accelerator or brake is released. Because the vehicle can gain significant speed during roll-back, the torque needed to re-start on the ramp is lower than an unrestricted roll-back speed.

### Section 2.1.6 On-Board Coil Drivers and Internal Coil Suppression

Coil drivers for the LINE and SP or BYPASS contactors are on-board the control card. These contactors must have coils rated for the vehicle battery volts.

## Section 2.2 System Protective Override

### Section 2.2.1 Static Return to Off (SRO)

This inherent safety feature of the control is designed to require the driver to return the directional lever to the neutral position anytime he leaves the vehicle and returns. Additionally, if the seat switch or key switch is opened, the control shuts off and cannot be restarted until the directional lever is returned to neutral. A time delay of approximately 2 seconds is built into the seat switch input to allow momentary opening of the seat switch, if a bump is encountered.

### Section 2.2.2 Accelerator Volts Hold Off

This feature checks the voltage level at the accelerator input whenever the key switch or seat switch is activated. If, at start-up, the voltage is greater than 0.9 volts, the control will not operate. This feature assures that the control is calling for low speed operation at start up.

### Section 2.2.3 Pulse Monitor Trip (PMT)

The PMT design contains three features which shut down, or lock out, control operation if a fault conditions occurs that would cause a disruption of normal vehicle operation:

- Look ahead
- Look again
- Automatic look again and reset

The PMT circuit will not allow the control to start under the following conditions:

- The control monitors both armature and field FET's at start-up and during running.

- The control will not allow the line contactor to close at start-up, or will drop it out during running, if either the armature or field FET's are defective, so as to cause uncontrolled truck movement.

### Section 2.2.4 Thermal Protector (TP)

This temperature sensitive device is internal to the power transistor (Q1) module. If the transistor's temperature begins to exceed the design limits, the thermal protector will lower the maximum current limit to 200 amps. As the control cools, the thermal protector will automatically reset, returning the control to full power.

### Section 2.2.5 Low Voltage Detection

Batteries under load, particularly if undersized or more than 80 percent discharged, will produce low voltages at the control terminals. The SX control is designed for use down to 50 percent of a nominal battery voltage of 36-84 volts, and 75 percent of a nominal battery voltage of 24 volts. Lower battery voltage may cause the control to operate improperly, however, the resulting PMT should open the Line contactor, in the event of a failure.

## Section 2.3 Diagnostics

### Section 2.3.1 Status Codes

#### Section 2.3.1.a Standard Status Codes

The SX control has a wide variety of Status Codes that assist the service technician and operator in trouble shooting the vehicle. If mis-operation of the vehicle occurs, a status code will be displayed on the Dash Display for vehicles so equipped, or be available from the status code displayed when the Handset is plugged into the "Y" plug of the logic card.

With the status code number, follow the procedures outlined in DIAGNOSTIC STATUS CODES to determine the problem and appropriate corrective action.

*Note: The Status Code Instruction Sheets do not purport to cover all possible causes of a display of a "status code". They do provide instructions for checking the most direct inputs that can cause status codes to appear.*

#### Section 2.3.1.b Stored Status Codes

This feature records the last 16 "Stored Status Codes" that have caused a PMT controller shut down and/or disrupted normal vehicle operation. (PMT type faults are reset by cycling the key switch). These status codes, along with the corresponding BDI and hourmeter readings, can be accessed with the Handset, or by using the RS 232 communications port and dumping the information to a Personal Computer terminal.

**Section 2.3.2 Hourmeter Readings**

This feature will display the recorded hours of use of the traction and pump control to the Dash Display each time the key switch is turned off.

**Section 2.3.2.a Maintenance Alert Status Code**

This feature is used to display a "99" status code when the vehicle operating hours match the hours set into the maintenance alert register. This feature is set with the Handset using Functions 19 and 20. The operator is alerted that maintenance on the vehicle is required.

**Section 2.3.3 Battery Discharge Indication (BDI)**

The latest in microprocessor technology is used to provide accurate battery state of charge information and to supply passive and active warning signals to the vehicle operator. Features and functions:

- Displays 100 to 0 percent charge.
- Display blinks with 20% charge. Option to disable pump circuit with 9% charge. Auto ranging for 36/48 volt operation. Adjustable for use on 24 to 80 volts.

**Section 2.3.3.a Internal Resistance Compensation**

This feature is used when the Battery Discharge Indicator is present. Adjustment of this function optimizes BDI with among different brands of batteries.

**Section 2.3.4 Handset**

This is a multi-functional tool used with the LX, ZX, and SX Series GE solid state controls. The Handset consists of a Light Emitting Diode (LED) display and a keyboard for data entry. Note, for ordering purposes, a separate Handset part number is required for SX controls.

Features and functions:

- Monitor existing system status codes for both traction and pump controls. Monitor intermittent random status codes.
- Monitor battery state of charge, if available.
- Monitor hourmeter reading on traction and pump controls.
- Monitor or adjust the control functions.

**Section 2.3.5 Circuit Board Coil Driver Modules**

Coil drivers are internal to the control card, and are the power devices that operate the Line, 1A and SP contactor coils. On command from the control card, these drivers initiate opening and closing the contactor coils. All driver modules are equipped with reverse battery protection, such

that, if the battery is connected incorrectly, the contactors cannot be closed electrically.

**Section 2.3.6 Selectable Truck Modes**

Through the adjustment of Function 1 of the controller, the following truck parameters are automatically adjusted to the values set below:

Description	Mode 1	Mode 2	Mode 3	Mode 4
Function 1 Setting	0 to 31	32 to 63	64 to 95	96 to 255
Min Field Current	Function 48 of the Handset Function 97 of the Computer	Function 52 of the Handset Function 101 of the Computer	Function 56 of the Handset Function 105 of the Computer	Function 60 of the Handset Function 109 of the Computer
Field Weakening Start	Function 49 of the Handset Function 98 of the Computer	Function 53 of the Handset Function 102 of the Computer	Function 57 of the Handset Function 106 of the Computer	Function 61 of the Handset Function 110 of the Computer
Ratio	Function 50 of the Handset Function 99 of the Computer	Function 54 of the Handset Function 103 of the Computer	Function 58 of the Handset Function 107 of the Computer	Function 62 of the Handset Function 111 of the Computer
Regen Braking Current Limit	Function 51 of the Handset Function 100 of the Computer	Function 55 of the Handset Function 104 of the Computer	Function 56 of the Handset Function 108 of the Computer	Function 63 of the Handset Function 112 of the Computer



**Section 3.0 ORDERING INFORMATION, ELEMENTARY AND OUTLINE DRAWINGS**

**Section 3.1 Ordering Information for Separately Excited Controls**

Example:

<b>Part Number:</b>	<b>IC3645</b>	<b>SE</b>	<b>4</b>	<b>D</b>	<b>33</b>	<b>2</b>	<b>C3</b>
Argument Number:	01	02	03	04	05	06	07

**Argument 01:** Basic Electric Vehicle Control Number

**Argument 02:** Control Type:  
 SH = Separately Excited Control ( Plugging )  
 SR = Separately Excited Control ( Regen to Zero )

**Argument 03:** Operating Voltage:

1 = 120 volts	5 = 36/48 volts
2 = 24 volts	6 = 24/36 volts
3 = 36 volts	7 = 72/80 volts
4 = 48 volts	

**Argument 04:** Package Size:

D = 6.86" X 6.67"
R = 6.86" X 8.15"
U = 8.66" X 8.13"
W = 8.66" X 10.83"

**Argument 05:** Armature Current  
 ( 2 characters )

22 = 220 Amps
33 = 330 Amps
40 = 400 Amps

etc.

**Argument 06:** Field Current  
 ( 1 character )

2 = 20 Amps
3 = 30 Amps
4 = 40 Amps

etc.

**Argument 07:** Customer / Revision

A1 = Customer A / Revision 1
B1 = Customer B / Revision 1

etc.

Section 3.2 Outline: SX-2 Package Size

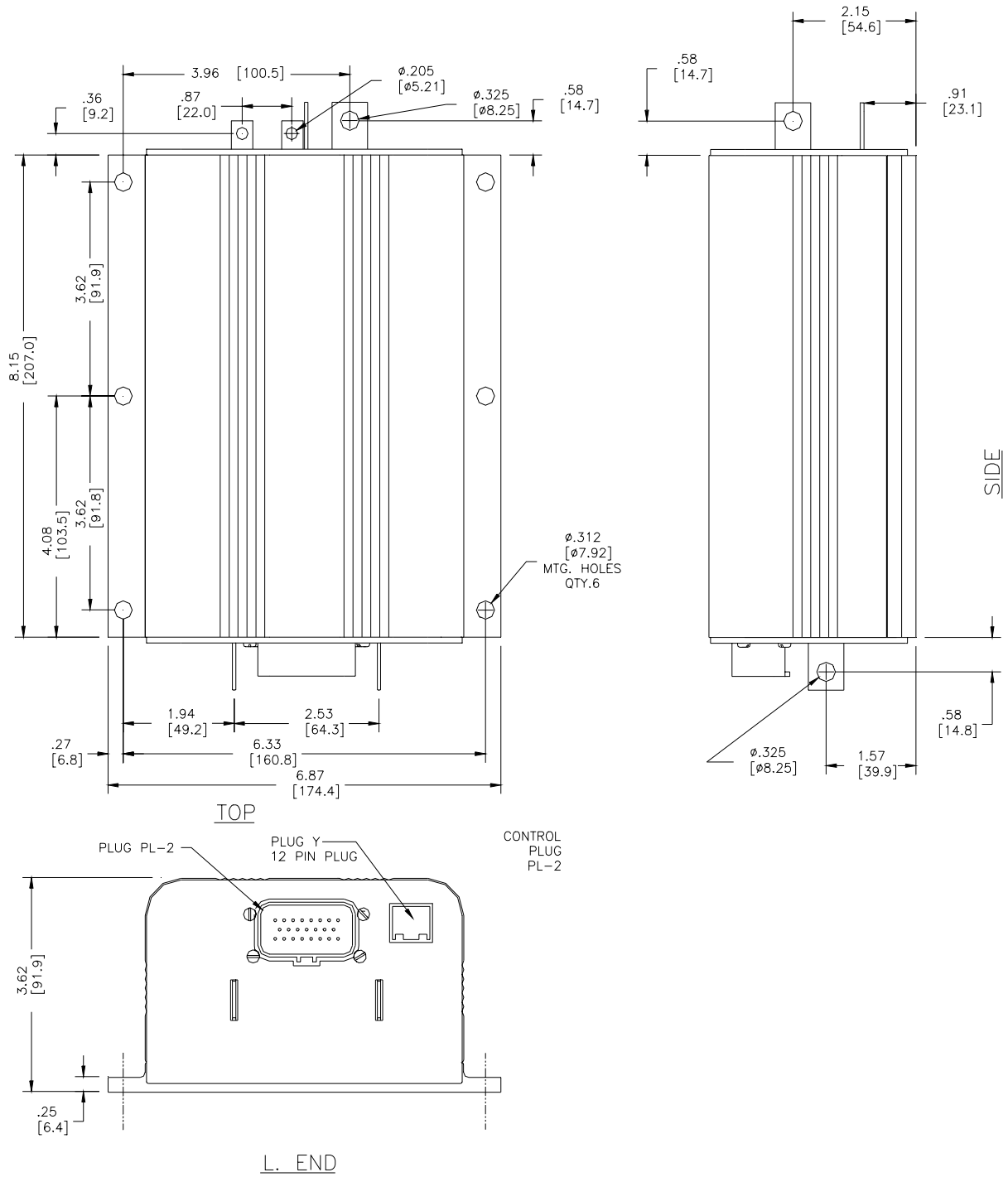

Section 3.3 Standard Elementary for Center Ride Application

ELEMENTARY DRAWING FOR  
 SEPARATELY EXCITED SINGLE  
 MOTOR CONTROLLER FOR CENTER  
 RIDE APPLICATION

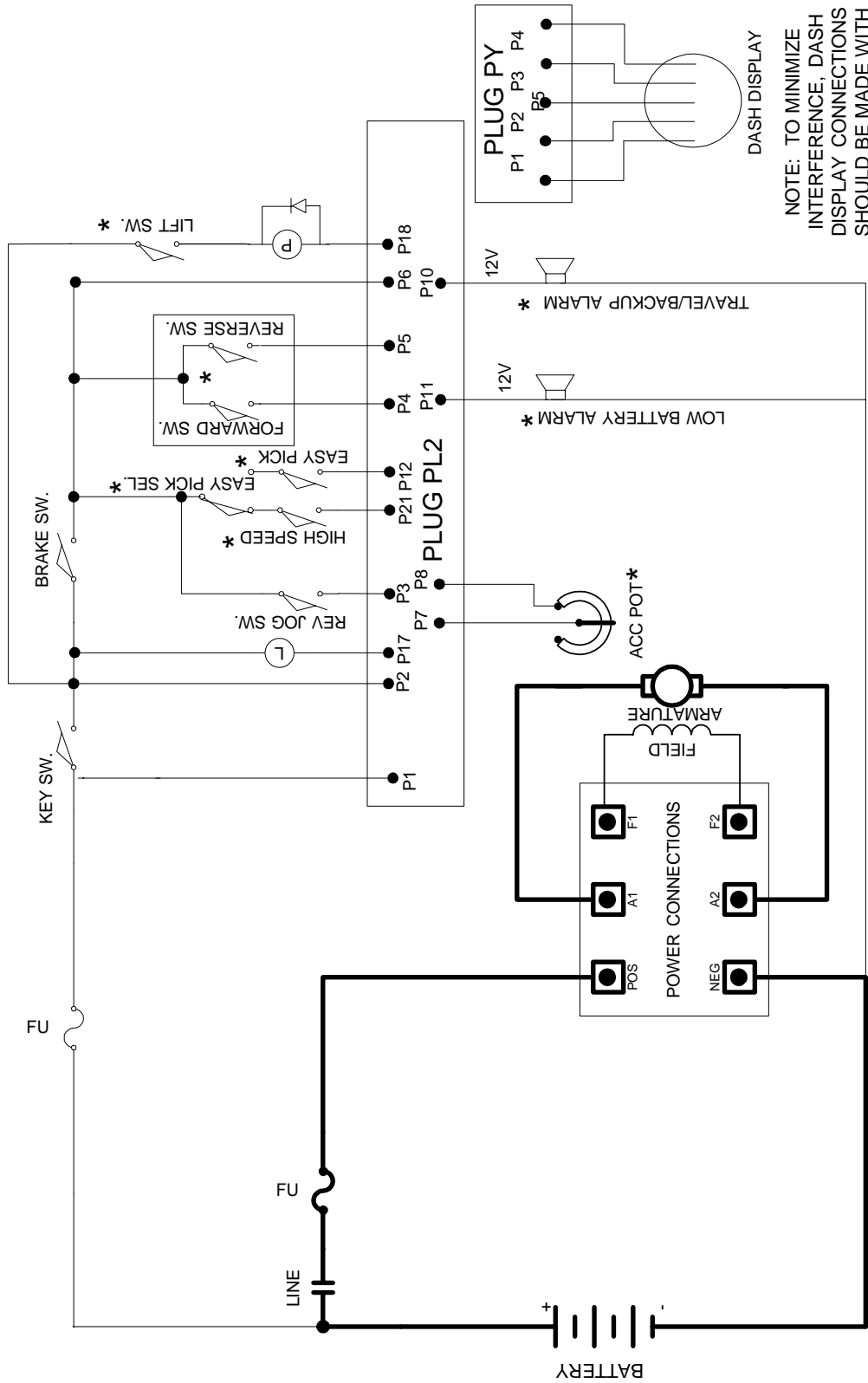

Section 3.4 Standard Elementary for Tugger Application

ELEMENTARY DRAWING FOR  
 SEPARATELY EXCITED SINGLE  
 MOTOR CONTROLLER FOR TUGGER  
 APPLICATION

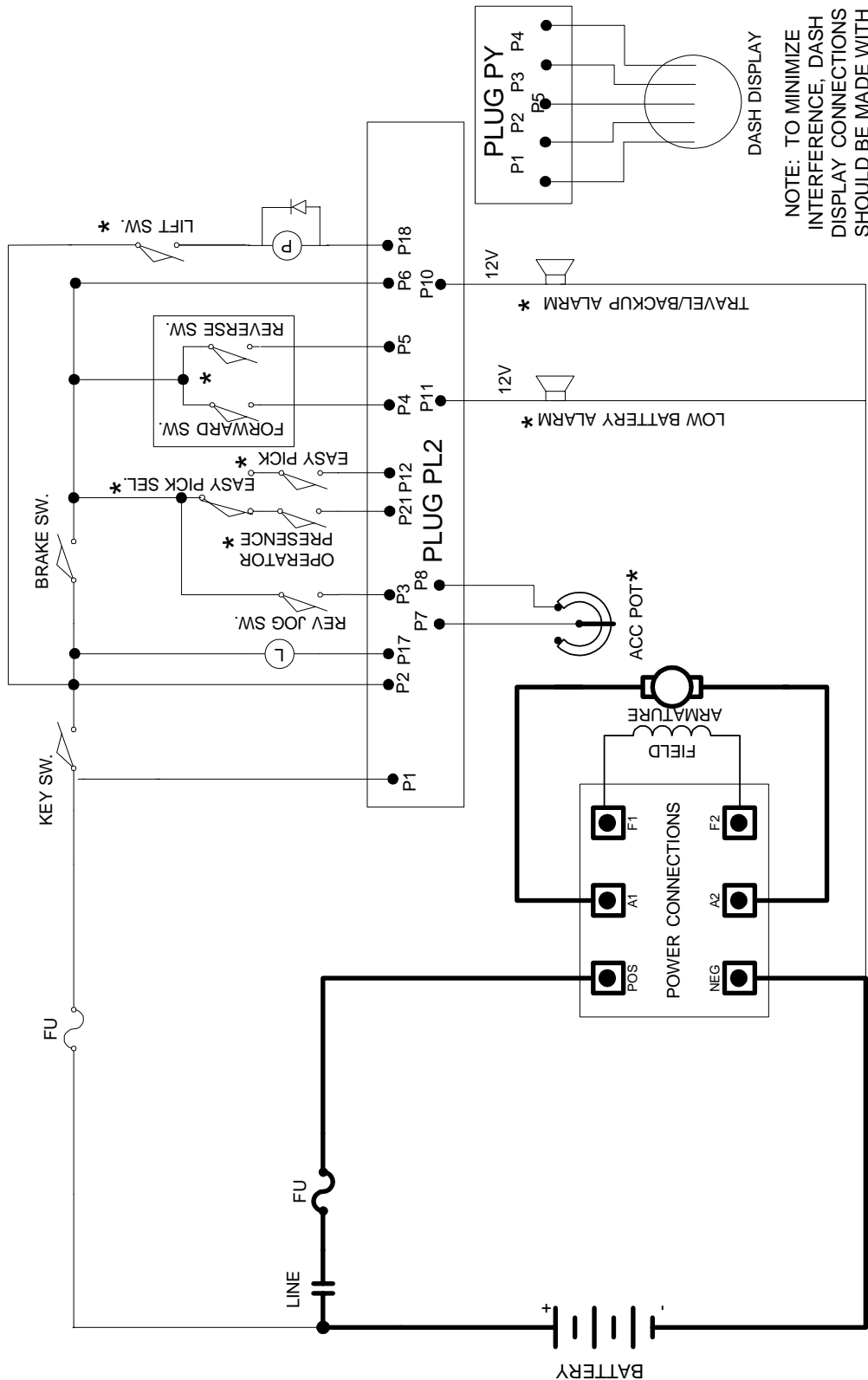

Section 3.5 Standard Center Ride/Tugger Application Input/Output List

Connections to Main Plug (23 Pin) and "Y" Plug (12 Pin)

STANDARD CENTER RIDE/TUGGER MAIN PLUG INPUT/OUTPUT DESCRIPTION	
PIN	
1	BATTERY VOLTS FROM BATTERY
2	BATTERY VOLTS FROM KEY
3	BATTERY VOLTS FROM REVERSE JOG SWITCH
4	BATTERY VOLTS FROM FORWARD SWITCH
5	BATTERY VOLTS FROM REVERSE SWITCH
6	BATTERY VOLTS FROM BRAKE SWITCH
7	ACCELERATOR INPUT VOLTAGE SIGNAL
8	ACCELERATOR NEGATIVE
9	ACCELERATOR POT +5 VOLTS SUPPLY
10	BACK UP ALARM/TRAVEL ALARM
11	BDI OUTPUT 12V = LOW BATTERY
12	BATTERY VOLTS EASY PICK SWITCH
13	N/A
14	N/A
15	N/A
16	N/A
17	LINE CONTACTOR DRIVER
18	PUMP CONTACTOR DRIVER
19	N/A
20	N/A
21	BATTERY VOLTS FROM JACK RABBIT/OPERATOR PRESENCE SWITCH
22	N/A
23	N/A
MOTOR TRACTION "Y" PLUG INPUT/OUTPUT DESCRIPTION	
PIN	
1	CLOCK (OUT) ( DASH DISPLAY-4)
2	DATA (OUT) ( DASH DISPLAY-3)
3	ENABLE (OUT) ( DASH DISPLAY-1)
4	NEGATIVE ( DASH DISPLAY-2)
5	+5V SUPPLY ( DASH DISPLAY-5)
6	CONT/STORE (IN) (HANDSET)
7	MOTOR CURRENT
8	VALUE (IN)(HANDSET)
9	FUNCTION (IN)(HANDSET)
10	N/A
11	SERIAL PORT (RECEIVE)
12	SERIAL PORT (TRANSMIT)

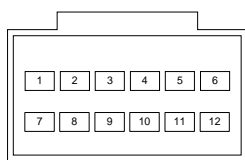

WIRE END VIEW "Y" PLUG

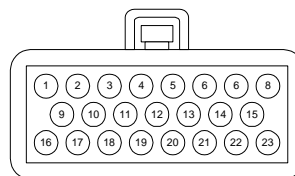

WIRE END VIEW - MAIN PLUG

## Section 4.0 TROUBLESHOOTING AND DIAGNOSTIC STATUS CODES

### Section 4.1 General Maintenance Instructions

The transistor control, like all electrical apparatus, does have some thermal losses. The semiconductor junctions have finite *temperature* limits, above which these devices may be damaged. For these reasons, normal maintenance should guard against any action which will expose the components to excessive heat and/or those conditions which will reduce the heat dissipating ability of the control, such as restricting air flow.

*The following Do's and Don't's should be observed:*

Any controls that will be applied in ambient temperatures over 100° F (40° C) should be brought to the attention of the vehicle manufacturer.

All external components having inductive coils must be filtered. Refer to vehicle manufacturer for specifications.

*The wiring should not be directly steam cleaned.* In dusty areas, blow low-pressure air over the control to remove dust. In oily or greasy areas, a mild solution of detergent or denatured alcohol can be used to wash the control, and then low-pressure air should be used to completely dry the control.

For the control to be most effective, it must be mounted against the frame of the vehicle. The metal vehicle frame, acting as an additional heat sink, will give improved vehicle performance by keeping the control package cooler. *Apply a thin layer of heat-transfer grease (such as Dow Corning 340) between the control heat sink and the vehicle frame.*

Control wire plugs and other exposed transistor control parts should be kept free of dirt and paint that might change the effective resistance between points.

***CAUTION: The vehicle should not be plugged when the vehicle is jacked up and the drive wheels are in a free wheeling position. The higher motor speeds can create excessive voltages that can be harmful to the control.***

Do not hipot (or megger) the control. Refer to control manufacturer before hipotting.

Use a lead-acid battery with the voltage and ampere hour rating specified for the vehicle. Follow normal battery maintenance procedures, recharging before 80 percent discharged with periodic equalizing charges.

Visual inspection of GE contactors contained in the traction and pump systems is recommended to occur during every

160 hours of vehicle operation. Inspection is recommended to verify that the contactors are not binding and that the tips are intact and free of contaminants.

GE does not recommend that any type of welding be performed on the vehicle after the installation of the control(s) in the vehicle. GE will not honor control failures during the warranty period when such failures are attributed to welding while the control is installed in the vehicle.

### Section 4.2 Cable Routing and Separation

Electrical noise from cabling of various voltage levels can interfere with a microprocessor-based control system. To reduce this interference, GE recommends specific cable separation and routing practices, consistent with industry standards.

#### Section 4.2.1 Application Responsibility

The customer and customer's representative are responsible for the mechanical and environmental locations of cables. They are also responsible for applying the level rules and cabling practices defined in this section. To help ensure a lower cost, noise-free installation, GE recommends early planning of cable routing that complies with these level separation rules.

On new installations, sufficient space should be allowed to efficiently arrange mechanical and electrical equipment. On vehicle retrofits, level rules should be considered during the planning stages to help ensure correct application and a more trouble-free installation.

#### Section 4.2.2. Signal/Powerlevel Definitions

The signal/power carrying cables are categorized into four defining levels: low, high, medium power, and high power. Within those levels, signals can be further divided into classes.

Sections 4.2.2.a through 4.2.2.d define these levels and classes, with specific examples of each. Section 4.2.3 contains recommendations for separating the levels.

#### Section 4.2.2.a Low-Level Signals (Level L)

Low-level signals are designated as *level L*. These consist of:

- Analog signals 0 through  $\pm 15$  V
- Digital signals whose logic levels are less than 15 V DC
- 4 – 20 mA current loops
- DC busses less than 15 V and 250 mA

The following are specific examples of level L signals used in drive equipment cabling:

- Control common tie
- DC buses feeding sensitive analog or digital hardware

- All wiring connected to components associated with sensitive analog hardware with less than 5V signals (for example, potentiometers and tachometers)
- Digital tachometers and resolvers
- Dash display cabling
- RS-232 cabling

**Note:** Signal inputs to analog and digital blocks should be run as shielded twisted-pair (for example, inputs from tachometers, potentiometers, and dash displays).

#### Section 4.2.2.b High-Level Signals (Level H)

High-level signals are designated as *level H*. These signals consist of:

- Analog and digital signals greater than 15 V DC and less than 250 mA

For example, switch inputs connected to battery volts are examples of level H signals used in drive equipment cabling.

#### Section 4.2.2.c Medium-Power Signals (Level MP)

Medium power signals are designated as *level MP*. These signals consist of:

- DC switching signals greater than 15 V
- Signals with currents greater than 250 mA and less than 10A

The following are specific examples of level MP signals used in drive equipment cabling:

- DC busses less than 10 A
- Contactor coils less than 10 A
- Machine fields less than 10 A

#### Section 4.2.2.d High Power Signals (Level HP)

Power wiring is designated as *level HP*. This consists of DC buses and motor wiring with currents greater than 10 A. The following are specific examples of level HP signals used in drive equipment cabling:

- Motor armature loops
- DC outputs 10 A and above
- Motor field loops 10 A and above

#### Section 4.2.3. Cable Spacing Guidelines

Recommended spacing (or clearance) between cables (or wires) is dependent on the level of the wiring inside them. For correct level separation when installing cable, the customer must apply the **general guidelines** (section 4.2.3.a), outlined below.

#### Section 4.2.3.a General Cable Spacing

The following general practices should be used for *all levels* of cabling:

- All cables and wires of like signal levels and power levels must be grouped together.
- In general, different levels must run in separate wire bundles, as defined in the different classes, identified above. Intermixing cannot be allowed, unless noted by exception.
- Interconnecting wire runs should carry a level designation.
- If wires are the same level and same type signal, group those wires from one location to any other location together in multiconductor cables or bind them together with twine or zip-ties.
- When unlike signals must cross, cross them in 90° angles at a maximum spacing. Where it is not possible to maintain spacing, place a grounded steel barrier between unlike levels at the crossover point.

#### Section 4.2.4 Cabling for Vehicle Retrofits

Reducing electrical noise on vehicle retrofits requires careful planning. Lower and higher levels should never encircle each other or run parallel for long distances. It is practical to use existing wire runs or trays as long as the level spacing (see section 4.2.2) can be maintained for the full length of the run.

Existing cables are generally of high voltage potential and noise producing. Therefore, route levels L and H in a path separate from existing cables, whenever possible. For level L wiring, use barriers in existing wire runs to minimize noise potential.

Do not loop level L signal wires around level H, level MP, or HP wires.

#### Section 4.2.5 RF Interference

To prevent radio frequency (RF) interference, care should be taken in routing power cables in the vicinity of radio-controlled devices.

#### Section 4.2.6 Suppression

Unless specifically noted otherwise, suppression (for example, a snubber) is required on all inductive devices controlled by an output. This suppression minimizes noise and prevents damage caused by electrical surges.

### Section 4.3 Recommended Lubrication of Pins and Sockets Prior to Installation

Beginning in January of 1999, GE will implement the addition of a lubricant to all connections using pins and sockets on EV100/EV200 and Gen II products. Any connection made by GE to the A, B, X, Y, or Z plugs will have the lubricant NYE 760G added to prevent fretting of these connections during vehicle operation.

Fretting occurs during microscopic movement at the contact points of the connection. This movement exposes the base metal of the connector pin which, when oxygen is present, allows oxidation to occur. Sufficient build up of the oxidation can cause intermittent contact and intermittent vehicle operation. This can occur at any similar type of connection, whether at the control or in any associated vehicle wiring, and the resultant intermittent contact can provide the same fault indication as actual component failure.

The addition of the NYE 760G lubricant will prevent the oxidation process by eliminating the access of oxygen to the contact point. GE recommends the addition of this lubricant to the 12 pin and 23 pin plugs of all new Gen II controls at the time of their installation into a vehicle.

When servicing existing vehicles exhibiting symptoms of intermittent mis-operation or shutdown by the GE control, GE recommends the addition of this lubricant to all 12 and 23 pin plugs, after proper cleaning of the connectors, as a preventative measure to insure fretting is not an issue before GE control replacement. Also, for long term reliable control operation, the plug terminals must be maintained per these instructions with the recommended contact cleaner and lubricant which provides a high degree of environmental and fretting protection.

New and re-manufactured control plugs are cleaned and lubricated prior to shipment from the factory. However, in applications where severe vibration or high temperature cycling and excessive humidity ( such as freezers ) are present, it is recommended that the plug terminals be cleaned and lubricated every year, per this instructions. In normal applications, plug maintenance should be performed every two years, unless intermittent problems arise with the plugs, requiring more immediate attention.

**Warning: Do not use any other cleaners or lubricants other than the ones specified.**

**WARNING: Before conducting maintenance on the vehicle, jack up the drive wheels, disconnect the battery and discharge the capacitors. Consult the Operation and Service Manual for your particular vehicle for details on discharging the capacitors; this procedure differs between SCR and Transistor controls.**

1. **Disconnect** plug from controller or mating plug.
2. **Locate** the plug that contains the socket (female) terminals. *Maintenance needs only to be performed on the plug containing the socket (female) type terminals. Reconnecting the plugs will lubricate the pin (male) terminals.*
3. **Clean** each terminal using Chemtronics contact cleaner "Pow-R-WasH CZ " as shown in Figure 1.

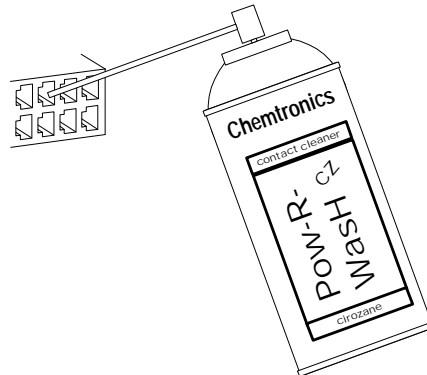

Figure 1

4. **Lubricate** each terminal using Nye 760G lubricant as shown in figure 2. Apply enough lubricant to each terminal opening to completely fill each opening to a depth of .125" maximum.

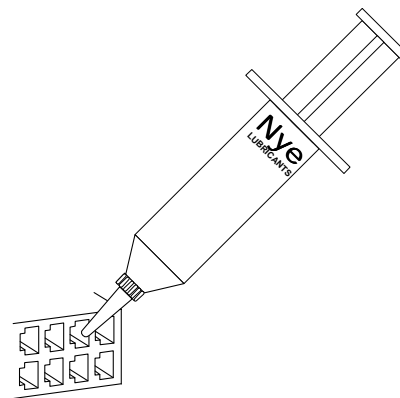

Figure 2

5. **Reconnect** plugs.

#### Reference

Cleaner	Chemtronics Pow-R-WasH CZ Contact Cleaner
Lubricant	Nye Lubricants NYOGEL 760G
GE Plug Lube Kit	Contains both above products: <b>328A1777G1</b>



### Section 4.4 Controller Mounting Guidelines

In the design of the GE family of motor controls, performance assumptions were made based on heat transfer between the control and the ambient environment. The vehicle mounting surface acts as a heat sink, which increases the effective surface area for heat dissipation. If this assumed heat transfer is not achieved during control installation and operation, GE controllers will fall short of their anticipated performance. It should be noted that the condition of the mounting surface, and the quality of the resulting interface between the control and the vehicle, can significantly hinder heat transfer from the control. The presence of contaminants, or of air voids created by surface inconsistencies in either the vehicle or the control, degrade the control's capacity for heat transfer. The control's performance is de-rated proportionally as its own thermal sensors reduce its operation to protect it from damage due to excessive heating.

Contained within the software of the GE controls are several diagnostic status codes related to controller thermal performance. Failure to follow these mounting recommendations increases the likelihood of encountering these status codes, through no fault of the control itself, thus voiding controller warranty for units returned solely due to the presence of these status codes.

Careful surface preparation, including adequate application of thermal compound, as detailed in the following paragraphs, must be completed during the installation of GE controls. There are many techniques for applying thermal compound, and we have outlined one approach below that has shown to apply a consistent thickness of material.

#### Section 4.4.1 Necessary Tools

GE recommends the use of the following components, or equivalent substitutions, during the control installation process:

- a) Thermal compound, (Dow Corning #340), maintained per the manufacturer's recommendations and free of contaminants
- b) 3/32" notched trowel, such as a Krusin adhesive spreader, model 00031
- c) Calibrated torque wrench (0 – 15 ft-lbs)

#### Section 4.4.2 The GE Control Mounting Surface

During the manufacture of the GE control, the surface flatness is maintained at 0.005" per linear inch (not to exceed 0.025" per 10.0 inches). The surface finish of the GE control has an  $R_a$  (average roughness) of 64 (microinches), or better. This finish is consistent with cold rolled or extruded aluminum.

Care should always be taken in the handling and storage of controllers. The base of the control should be free from nicks, bumps, protrusions or any other foreign object that

would prevent the control from sitting flush with the vehicle mounting surface. Examine the base of the control to verify that it is in good condition and free from damage or contamination.

#### Section 4.4.3 Vehicle Mounting Surface

The quality of the vehicle mounting surface is critical for the optimum heat transfer between the control and the ambient environment. Conduction through the base of the control is the control's only means of heat rejection. While GE controls are highly efficient, a few percent of the electrical energy will be converted into heat. As previously mentioned, if this energy is not dissipated through the base of the control, a thermal protector will reduce the performance of the control until the temperature stabilizes.

For optimal heat transfer from control to vehicle, the flatness of the vehicle mounting surface should be equivalent to the flatness of the control surface (0.005" per linear inch). Use a straight edge or dial indicator to verify the mounting surface.

The biggest hindrance to heat transfer is the presence of rust, scale, weld splatter or paint on the vehicle mounting surface. If any of these items are noted, prepare the surface per the following guidelines:

- a) Clean the mounting surface with a rotary wire brush until the metal surface is exposed.
- b) Using 80-100 grit emery paper, sand the surface until the metal shines.
- c) Flush the surface clean with an appropriate liquid de-greaser or parts cleaner.

#### Section 4.4.4 Application of Thermal Compound

Due to the minute differences in the control mounting surface and the vehicle mounting surface, small pockets of air will be created. These air pockets will add to the overall thermal resistance of the interface.

To avoid these air pockets and improve thermal conductivity, thermal compound must be applied between the GE control base plate and the vehicle mounting surface. The function of this compound is to conform to surface discrepancies, filling gaps and optimizing the metal-to-metal contact of the control and the vehicle.

- a) Prepare the two mounting surfaces (control and vehicle) as indicated above.
- b) Using a triangular notched trowel of 3/32" (.09" +/- .01), apply the grease to the vehicle mounting surface.
- c) Use straight, non-crossing strokes of the trowel to apply the compound.
- d) Make multiple vertical passes until a uniform consistency is achieved.



Krusin adhesive spreader model 00031



Vehicle surface after proper grease application

**Section 4.4.5 Mounting the GE Control**

- Place the control unit with desired orientation on mounting plate with mounting holes aligned.
- Move the control slightly in all directions to eliminate voids and enhance the distribution of the thermal compound.
- Insert the all of the mounting hardware (4, 6 or 8 bolts, M6 or M8, necessary for the mounting of the respective family of controls).
- Tighten these bolts (as per sequence shown in diagrams below) to half of the nominal torque value (**7.5lb-ft**).
- Lastly, tighten the bolts to the nominal torque value (**15 lb-ft**), following the same sequence.



Calibrated torque wrench for hardware installation

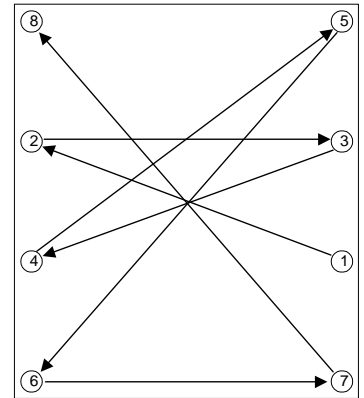
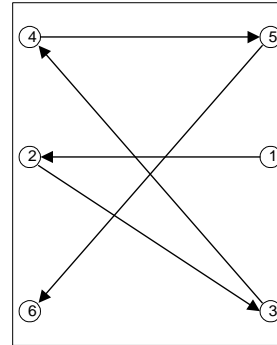
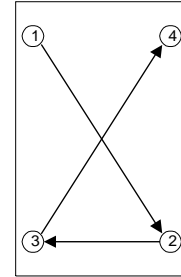
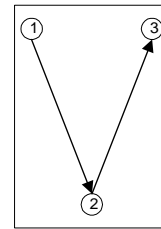

Proper sequence for use in tightening hardware during control mounting

**Section 4.4.6 Maintenance**

If it is necessary to remove the control for service, careful consideration must be given to removing the old thermal compound from the control and mounting surface, prior to replacement of the unit. **Never** re-use thermal compound. Use a putty knife or similar straight edge to carefully remove all thermal compound residue without damaging either mounting surface. Flush the surfaces with a liquid de-greaser or parts cleaner and allow them to dry, before re-applying the thermal compound and mounting the control. Take care not to contaminate the surfaces with hydraulic fluid or battery acid.

**Section 4.5 General Troubleshooting Instructions**

Trouble-shooting the SX family of controls should be quick and easy when following the instructions outlined in the following status code instruction sheets.

If mis-operation of the vehicle occurs, a status code will be displayed on the Dash Display (for vehicles equipped with a Dash Display) or made available by plugging a Handset into the plug "Y" location, and then reading the status code.

**Note:** Status code numbers from 00 to 99 are traction control status codes. Status codes with the prefix 1 (101 to 199) are pump control status codes.

With the status code number, follow the procedures outlined in the status code instruction sheets to determine the problem.

**Important Note:** Due to the interaction of the logic card with all vehicle functions, almost any status code or control fault could be caused by the logic card. After all other status code procedures have been followed and no problem is found, the controller should then be replaced as the last option to correct the problem.

The same device designations have been maintained on different controls but the wire numbers may vary. Refer to the elementary and wiring diagrams for your specific control. The wire numbers shown on the elementary diagram will have identical numbers on the corresponding wiring diagrams for a specific vehicle, but these numbers may be different from the numbers referenced in this publication.

**WARNING: Before trouble-shooting, jack up the drive wheels, disconnect the battery and discharge the capacitors. Reconnect the battery as needed for specific checks. Capacitors should be discharged by connecting a 200 ohm 2 watt resistor between the positive and negative terminals on the control panel.**

Check resistance on R x 1000 scale from frame to power and control terminals. A resistance of less than 20,000 ohms can cause misleading symptoms. Resistance less than 1000 ohms should be corrected first.

Before proceeding, visually check for loose wiring, mis-aligned linkage to the accelerator switch, signs of overheating of components, etc.

Tools and test equipment required are: clip leads, volt-ohm meter (20,000 ohms per volt) and basic hand tools.

Section 4.6 Traction Control Status Codes

TRACTION STATUS CODE	DESCRIPTION OF STATUS	CAUSE OF STATUS INDICATION
<b>NONE</b>	Segments do not illuminate on the Dash Display and/or the Handset.	No input voltage to the control card or the display unit.
MEMORY RECALL <b>NO</b>	<b>CORRECTIVE ACTIONS</b>	<b>TROUBLE-SHOOTING DIAGRAM</b>
Circuits valid for Traction Controller	<p><b>SYMPTOM</b> Display screen on Dash Display and/or Handset is blank.</p> <p><b>POSSIBLE CAUSE</b> Positive or negative control voltage is not present.</p> <ul style="list-style-type: none"> <li>Insure that the key switch is closed and voltage is present between P1 &amp; battery negative (Power Terminal "NEG"). Also check for voltage between P2 and control negative.</li> </ul> <p>Open circuit between control card Plug Y &amp; the Dash Display or Handset.</p> <ul style="list-style-type: none"> <li>Check for an open circuit or loose connection going from the "Y" plug and the Dash Display or Handset.</li> </ul> <p>Defective Dash Display or Handset.</p> <ul style="list-style-type: none"> <li>Replace Dash Display or Handset.</li> </ul>	

TRACTION STATUS CODE	DESCRIPTION OF STATUS	CAUSE OF STATUS INDICATION
<b>-02</b>	Forward directional switch is closed on initial power up.	This status code will be displayed when P4 is greater than 60% of battery voltage at initial key switch on.
MEMORY RECALL <b>NO</b>	<b>CORRECTIVE ACTIONS</b>	<b>TROUBLE-SHOOTING DIAGRAM</b>
Circuits valid for Traction Controller	<p><b>SYMPTOM</b> Control will not operate because of Static Return to Off (SRO) lock out.</p> <p><b>POSSIBLE CAUSE</b> Forward directional switch is closed on initial start up (i.e. closure of battery, key switch or foot switch).</p> <ul style="list-style-type: none"> <li>Return directional switch lever to neutral and then return lever to forward position.</li> </ul> <p>Forward directional switch is welded closed or mis-adjusted to be held closed.</p> <ul style="list-style-type: none"> <li>Replace or adjust directional switch to insure that it opens when the directional switch is returned to neutral.</li> </ul> <p>Short circuit between P3 and P4.</p> <ul style="list-style-type: none"> <li>Disconnect the wire from P4 and check for a short circuit between P3 and the wire that was connected to P4.</li> </ul> <p>Defective control.</p> <ul style="list-style-type: none"> <li>Replace the controller unit.</li> </ul>	

TRACTION STATUS CODE	DESCRIPTION OF STATUS	CAUSE OF STATUS INDICATION
<b>-03</b>	Reverse directional switch is closed on initial power up.	This status code will be displayed when P5 is greater than 60% of battery voltage at initial key switch on.
MEMORY RECALL <b>NO</b>	<b>CORRECTIVE ACTIONS</b>	<b><u>TROUBLE-SHOOTING DIAGRAM</u></b>
Circuits valid for Traction Controller	<p><b><u>SYMPTOM</u></b> Control will not operate because of Static Return to Off (SRO) lock out.</p>	
	<p><b><u>POSSIBLE CAUSE</u></b> Reverse directional switch is closed on initial start up (i.e. closure of battery, key switch or foot/deadman switch).</p> <ul style="list-style-type: none"> <li>Return directional switch lever to neutral and then return lever to reverse position.</li> </ul> <p>Reverse directional switch is welded closed or mis-adjusted to be held closed.</p> <ul style="list-style-type: none"> <li>Replace or adjust directional switch to insure that it opens when the directional switch is returned to neutral.</li> </ul> <p>Short circuit between P3 and P5.</p> <ul style="list-style-type: none"> <li>Disconnect the wire from P5 and check for a short circuit between P3 and the wire that was connected to P5.</li> </ul> <p>Defective control. Replace the controller unit.</p>	

TRACTION STATUS CODE	DESCRIPTION OF STATUS	CAUSE OF STATUS INDICATION
<b>-04</b>	Reverse jog switch is closed on start up (only applicable to tugger models)	This status code will be displayed when P3 is greater than 50% of battery voltage when the reverse jog switch is closed (if the jog function is disabled by Function 17)
MEMORY RECALL <b>NO</b>	<b>CORRECTIVE ACTIONS</b>	<b><u>TROUBLE-SHOOTING DIAGRAM</u></b>
Circuits valid for Traction Controller	<p><b><u>SYMPTOM</u></b> Control will not operate.</p>	
	<p><b><u>POSSIBLE CAUSE</u></b> Defective reverse jog switch circuit.</p> <ul style="list-style-type: none"> <li>Check reverse jog switch to insure that it is open when brake handle is pulled down.</li> <li>Check for open circuit or loose connections in wiring from key switch to brake switch and from P3 to brake switch.</li> </ul>	

TRACTION STATUS CODE	DESCRIPTION OF STATUS	CAUSE OF STATUS INDICATION
<b>-05</b>	Reverse jog switch is closed and the presence switch is open on start up. (only applicable to tugger)	This status code will be displayed when PL2-3 is closed and PL2-21 is open on tugger models.
MEMORY RECALL <b>NO</b>	<b>CORRECTIVE ACTIONS</b>	<b><u>TROUBLE-SHOOTING DIAGRAM</u></b>
Circuits valid for Traction Controller	<p><b><u>SYMPTOM</u></b> Control will not operate.</p> <p><b><u>POSSIBLE CAUSE</u></b> Defective reverse jog switch circuit.</p> <ul style="list-style-type: none"> <li>• Check reverse jog switch to insure that it is open when brake handle is pulled down.</li> <li>• Check for open circuit or loose connections in wiring from key switch to brake switch and from P3 to brake switch.</li> </ul>	

TRACTION STATUS CODE	DESCRIPTION OF STATUS	CAUSE OF STATUS INDICATION
<b>-06</b>	Accelerator depressed with no direction selected.	This status code will be displayed when P4 and P5 are less than 60% of battery volts, and P7 is less than 2.5 volts.
MEMORY RECALL <b>NO</b>	<b>CORRECTIVE ACTIONS</b>	<b><u>TROUBLE-SHOOTING DIAGRAM</u></b>
Circuits valid for Traction Controller	<p><b><u>SYMPTOM</u></b> Control will not operate.</p> <p><b><u>POSSIBLE CAUSE</u></b> Accelerator pedal is depressed before closing forward or reverse directional switch.</p> <ul style="list-style-type: none"> <li>• Status code will disappear when directional switch is closed or when accelerator pedal is released.</li> </ul> <p>Defective directional switch.</p> <ul style="list-style-type: none"> <li>• Check forward or reverse switch to insure closure when direction is selected.</li> </ul> <p>Open circuit between directional switch(es) and battery positive or between directional switch(es) and P4 or P5.</p> <ul style="list-style-type: none"> <li>• Check all control wires and connections shown in Trouble Shooting Diagram.</li> </ul>	

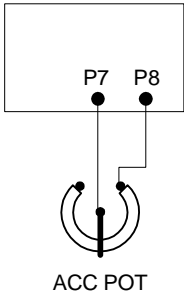
TRACTION STATUS CODE	DESCRIPTION OF STATUS	CAUSE OF STATUS INDICATION
<b>-07</b>	Accelerator input voltage too high.	This status code will be displayed when the accelerator input voltage at P7 is higher than 4.2 volts, and travel enable switch is selected.
MEMORY RECALL <b>NO</b>	<b>CORRECTIVE ACTIONS</b>	<b><u>TROUBLE-SHOOTING DIAGRAM</u></b>
Circuits valid for Traction Controller	<p><b><u>SYMPTOM</u></b> Control will not operate when accelerator pedal is depressed or status code -07 is displayed then disappears when the vehicle starts to accelerate.</p> <p><b><u>POSSIBLE CAUSE</u></b> Accelerator input mis-adjusted or defective.</p> <ul style="list-style-type: none"> <li>• Input voltage at P7 should be less than 3.7 volts. Adjust or replace accelerator unit to insure that the voltage at P7 will vary from 3.5 volts to less than .5 volts when the pedal is depressed.</li> </ul> <p>Open circuit between battery negative and P7 in accelerator input circuit.</p> <ul style="list-style-type: none"> <li>• Check for broken wires or loose connections or open potentiometer / voltage supply.</li> </ul> <p>Short circuit from battery positive to wiring in accelerator input circuit.</p> <ul style="list-style-type: none"> <li>• Disconnect wire from P7 and measure voltage at wire to negative. Should be zero volts for potentiometer type and less than 3.7 volts for solid state type accelerator input.</li> </ul>	 <p>ACC POT</p>

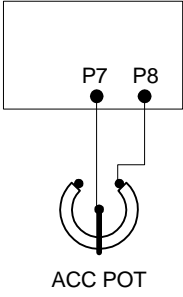
TRACTION STATUS CODE	DESCRIPTION OF STATUS	CAUSE OF STATUS INDICATION
<b>-08</b>	Accelerator input voltage too low on power up after initial key switch closure.	This status code will be displayed when the accelerator input voltage at P7 is less than 3.0 volts, and any of the following connections are opened and closed: battery plug or key switch.
MEMORY RECALL <b>NO</b>	<b>CORRECTIVE ACTIONS</b>	<b><u>TROUBLE-SHOOTING DIAGRAM</u></b>
Circuits valid for Traction Controller	<p><b><u>SYMPTOM</u></b> Control will not operate.</p> <p><b><u>POSSIBLE CAUSE</u></b> Accelerator input mis-adjusted or defective.</p> <ul style="list-style-type: none"> <li>• Input voltage at P7 should be more than 3.0 volts. Adjust or replace accelerator unit to insure that the voltage at P7 is more than 3.0 volts before depressing pedal.</li> </ul> <p>Short circuit between battery negative and TB1 in accelerator input circuit.</p> <ul style="list-style-type: none"> <li>• Disconnect wire from P7. Check for short circuit from wire to battery negative. Resistance should be greater than 4.7K ohms.</li> </ul> <p>Defective control.</p> <ul style="list-style-type: none"> <li>• Disconnect wire from P7. Measure voltage from TB1 to negative. Voltage should be greater than 4.5 volts, if not, replace control.</li> </ul>	 <p>ACC POT</p>

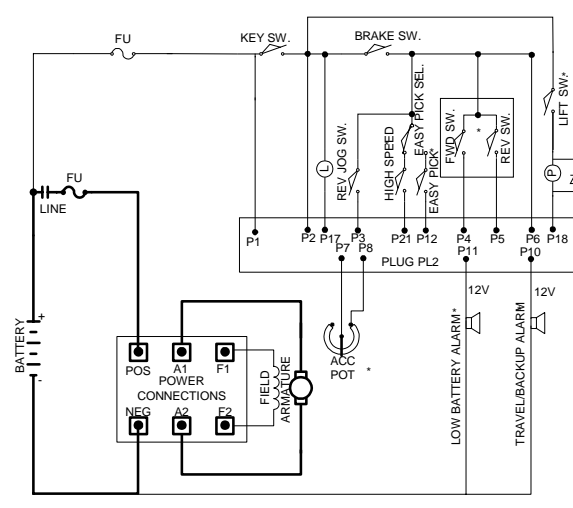
TRACTION STATUS CODE	DESCRIPTION OF STATUS	CAUSE OF STATUS INDICATION
<b>-09</b>	Both directional switches are closed.	This status code will be displayed when P5 and P4 are greater than 60% of battery volts.
MEMORY RECALL <b>NO</b>	<b>CORRECTIVE ACTIONS</b>	<b><u>TROUBLE-SHOOTING DIAGRAM</u></b> 
Circuits valid for Traction Controller	<b><u>SYMPTOM</u></b> Control will not operate.	
	<b><u>POSSIBLE CAUSE</u></b> Forward or reverse directional switch welded closed or mis-adjusted to be held closed. <ul style="list-style-type: none"> <li>Replace or adjust directional switches to insure that they open when directional switch is returned to neutral.</li> </ul> Short circuit between battery positive and P4 and/or P5. <ul style="list-style-type: none"> <li>Disconnect wires from P4 and P5 and check wire for short circuit to positive side of directional switch.</li> </ul> Defective Control <ul style="list-style-type: none"> <li>Disconnect wires and measure voltage at P4 and P5. Voltage should be less than 60% of battery volts.</li> </ul>	

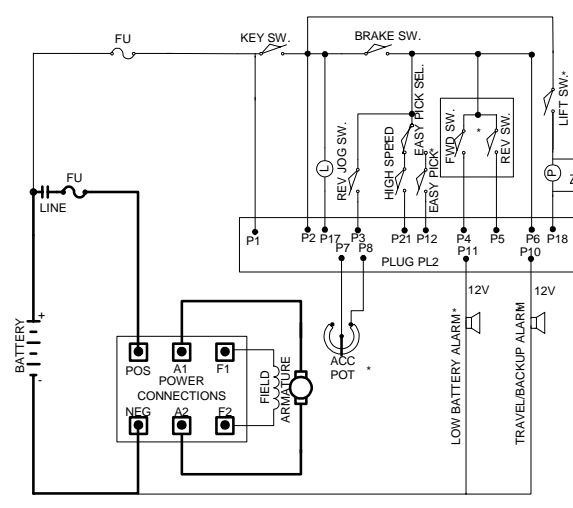
TRACTION STATUS CODE	DESCRIPTION OF STATUS	CAUSE OF STATUS INDICATION
<b>-14</b>	The easy pick switch is closed on start up.	This status code will be displayed when P12 is greater than 50% of battery volts at key on.
MEMORY RECALL <b>NO</b>	<b>CORRECTIVE ACTIONS</b>	<b><u>TROUBLE-SHOOTING DIAGRAM</u></b> 
Circuits valid for Traction Controller	<b><u>SYMPTOM</u></b> Control will not operate due to SRO lockout.	
	<b><u>POSSIBLE CAUSE</u></b> Easy pick switch is closed on initial start up. <ul style="list-style-type: none"> <li>Return easy pick switch to neutral position.</li> </ul> Easy pick switch is welded or misadjusted to be held closed. <ul style="list-style-type: none"> <li>Adjust or replace easy pick switch.</li> </ul> Defective control <ul style="list-style-type: none"> <li>Replace controller unit.</li> </ul>	

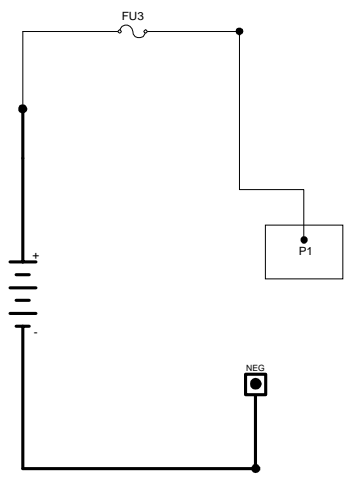

TRACTION STATUS CODE	DESCRIPTION OF STATUS	CAUSE OF STATUS INDICATION												
<b>-15</b>	Battery voltage is too low or control card is mis-adjusted.	This status code will be displayed when the battery volts are less than 1.95 volts per cell at initial key switch on. See table below.												
MEMORY RECALL <b>NO</b>	<b>CORRECTIVE ACTIONS</b>	<b><u>TROUBLE-SHOOTING DIAGRAM</u></b>												
Circuits valid for Traction Controller	<p><b><u>SYMPTOM</u></b> Control will not operate.</p> <p><b><u>POSSIBLE CAUSE</u></b> Discharged battery</p> <ul style="list-style-type: none"> <li>• Check battery for proper open circuit voltage as shown in "Trouble Shooting Diagram", charge battery, if required.</li> </ul> <p>Defective battery</p> <ul style="list-style-type: none"> <li>• Check each battery cell for proper voltage (greater than 1.95 volts at cell). Replace or repair battery.</li> </ul> <p>Incorrect control card adjustment.</p> <ul style="list-style-type: none"> <li>• Check Function 15 for proper adjustment for battery being used. See Handset instruction sheet for details. Adjust to proper settings.</li> </ul> <p>Check "minimum" battery volts at P1 and NEG.</p>	 <table border="1" data-bbox="1258 493 1485 724"> <thead> <tr> <th>NOMINAL BATTERY VOLTAGE</th> <th>MINIMUM LIMIT VOLTS AT 1.95 VDC PER CELL</th> </tr> </thead> <tbody> <tr> <td>24</td> <td>23.4</td> </tr> <tr> <td>36</td> <td>35.1</td> </tr> <tr> <td>48</td> <td>46.8</td> </tr> <tr> <td>72</td> <td>70.2</td> </tr> <tr> <td>80</td> <td>78.0</td> </tr> </tbody> </table>	NOMINAL BATTERY VOLTAGE	MINIMUM LIMIT VOLTS AT 1.95 VDC PER CELL	24	23.4	36	35.1	48	46.8	72	70.2	80	78.0
NOMINAL BATTERY VOLTAGE	MINIMUM LIMIT VOLTS AT 1.95 VDC PER CELL													
24	23.4													
36	35.1													
48	46.8													
72	70.2													
80	78.0													

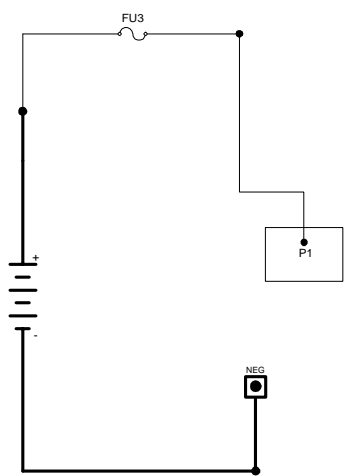
TRACTION STATUS CODE	DESCRIPTION OF STATUS	CAUSE OF STATUS INDICATION												
<b>-16</b>	Battery voltage is too high or control card is mis-adjusted.	This status code will be displayed when the battery volts are greater than 2.40 volts per cell at initial key switch on. See table below.												
MEMORY RECALL <b>NO</b>	<b>CORRECTIVE ACTIONS</b>	<b><u>TROUBLE-SHOOTING DIAGRAM</u></b>												
Circuits valid for Traction Controller	<p><b><u>SYMPTOM</u></b> Control will not operate.</p> <p><b><u>POSSIBLE CAUSE</u></b> Incorrect control card adjustment</p> <p>Check Function 15 for proper adjustment for battery being used. See Handset instructions for details. Adjust to proper setting.</p> <p>Battery over charged or incorrect battery used.</p> <ul style="list-style-type: none"> <li>• Check battery for proper open circuit voltage per table at right. If voltage is excessive, check battery charger for proper output voltage.</li> </ul> <p>Check "maximum" battery volts at P1 and NEG.</p>	 <table border="1" data-bbox="1258 1323 1485 1554"> <thead> <tr> <th>NOMINAL BATTERY VOLTAGE</th> <th>MAXIMUM LIMIT VOLTS AT 2.40 VDC PER CELL</th> </tr> </thead> <tbody> <tr> <td>24</td> <td>28.8</td> </tr> <tr> <td>36</td> <td>43.2</td> </tr> <tr> <td>48</td> <td>57.6</td> </tr> <tr> <td>72</td> <td>86.4</td> </tr> <tr> <td>80</td> <td>96.0</td> </tr> </tbody> </table>	NOMINAL BATTERY VOLTAGE	MAXIMUM LIMIT VOLTS AT 2.40 VDC PER CELL	24	28.8	36	43.2	48	57.6	72	86.4	80	96.0
NOMINAL BATTERY VOLTAGE	MAXIMUM LIMIT VOLTS AT 2.40 VDC PER CELL													
24	28.8													
36	43.2													
48	57.6													
72	86.4													
80	96.0													

TRACTION STATUS CODE	DESCRIPTION OF STATUS	CAUSE OF STATUS INDICATION
<b>-23</b>	Control interprets the motor field current as too high on start up in the reverse direction.	This status code will be displayed when the current draw in the motor field is too high (> 1.1V through <i>GE Sentry for Windows</i> software) at start up in the reverse direction.
MEMORY RECALL <b>NO</b>	<b>CORRECTIVE ACTIONS</b>	<b><u>TROUBLE-SHOOTING DIAGRAM</u></b>
Circuits valid for Traction Controller	<p><b><u>SYMPTOM</u></b> Control will not operate.</p> <p><b><u>POSSIBLE CAUSE</u></b> Defective control. • Replace controller unit.</p>	<b>NO GRAPHIC FOR THIS STATUS CODE</b>

TRACTION STATUS CODE	DESCRIPTION OF STATUS	CAUSE OF STATUS INDICATION
<b>-24</b>	Control interprets motor field current as too high on start up in the forward direction.	This status code will be displayed when the current draw in the motor field is too high (> 1.1V through <i>GE Sentry for Windows</i> software) at start up in the forward direction.
MEMORY RECALL <b>NO</b>	<b>CORRECTIVE ACTIONS</b>	<b><u>TROUBLE-SHOOTING DIAGRAM</u></b>
Circuits valid for Traction Controller	<p><b><u>SYMPTOM</u></b> Control will not operate.</p> <p><b><u>POSSIBLE CAUSE</u></b> Defective control. • Replace controller unit.</p>	<b>NO GRAPHIC FOR THIS STATUS CODE</b>

TRACTION STATUS CODE	DESCRIPTION OF STATUS	CAUSE OF STATUS INDICATION
<b>-27</b>	Power supply is less than 10 Volts DC.	This status code will be displayed when the power supply is less than 9.6 volts.
MEMORY RECALL <b>YES</b>	<b>CORRECTIVE ACTIONS</b>	<b><u>TROUBLE-SHOOTING DIAGRAM</u></b>
Circuits valid for Traction Controller	<p><b><u>SYMPTOM</u></b> Line contactor opens and closes, then can only be closed by opening and closing the key switch.</p> <p><b><u>POSSIBLE CAUSE</u></b> Discharged Battery</p> <ul style="list-style-type: none"> <li>Check battery to insure proper state of charge. Voltage may be dropping below 10 Volts DC under load.</li> </ul> <p>Loose connection at P1.</p> <ul style="list-style-type: none"> <li>Insure that the wire connection at P1 is tight.</li> </ul> <p>Defective control.</p> <ul style="list-style-type: none"> <li>Replace controller unit.</li> </ul>	

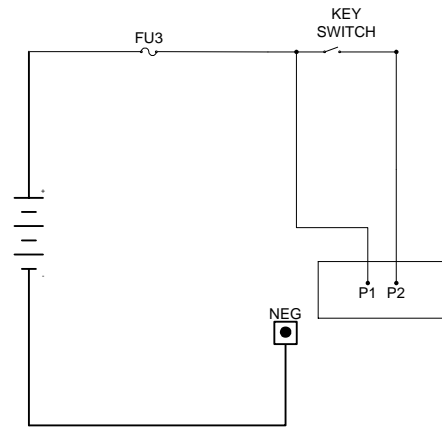

TRACTION STATUS CODE	DESCRIPTION OF STATUS	CAUSE OF STATUS INDICATION
<b>-28</b>	Motor field current is too high during the run mode.	This status code will be displayed when the current draw in the motor field is sustained above a preset limit for longer than 60 seconds.
MEMORY RECALL <b>NO</b>	<b>CORRECTIVE ACTIONS</b>	<b><u>TROUBLE-SHOOTING DIAGRAM</u></b>
Circuits valid for Traction Controller	<p><b><u>SYMPTOM</u></b> Control will not operate.</p> <p><b><u>POSSIBLE CAUSE</u></b> Continued operation of vehicle in high motor current condition.</p> <ul style="list-style-type: none"> <li>Operate vehicle at lower motor current condition for 35 seconds.</li> </ul> <p>Function 7 is mis-adjusted to allow higher than normal motor field current.</p> <ul style="list-style-type: none"> <li>Adjust this function per OEM instructions.</li> </ul>	

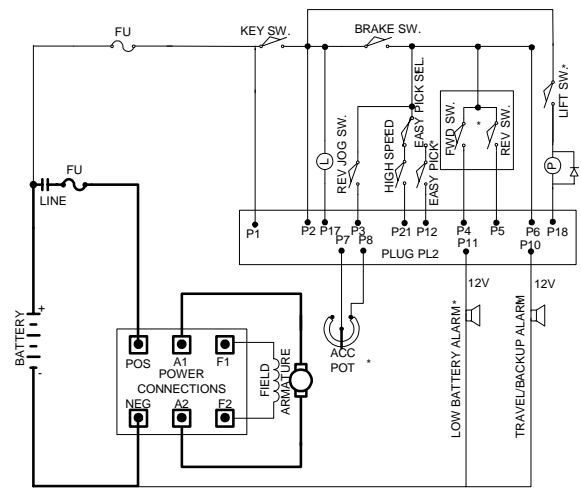

TRACTION STATUS CODE	DESCRIPTION OF STATUS	CAUSE OF STATUS INDICATION
<b>-41</b>	Open thermal protector (TP) or transistor over temperature.	This status code will be displayed when the voltage at the thermal protector is too high.
MEMORY RECALL <b>YES</b>	<b>CORRECTIVE ACTIONS</b>	<b><u>TROUBLE-SHOOTING DIAGRAM</u></b>          <b>NO GRAPHIC FOR THIS STATUS CODE</b>
Circuits valid for Traction Controller	<p><b><u>SYMPTOM</u></b> Reduced or no power to traction motor in control range.</p> <p><b><u>POSSIBLE CAUSE</u></b> Control is in thermal cut-back.</p> <ul style="list-style-type: none"> <li>• Allow control to cool, status code should disappear.</li> </ul> <p>Defective control.</p> <ul style="list-style-type: none"> <li>• Replace controller unit.</li> </ul>	

TRACTION STATUS CODE	DESCRIPTION OF STATUS	CAUSE OF STATUS INDICATION
<b>-42</b>	Motor armature offset voltage is too high.	This status code will be displayed when the voltage at the current sensor input is greater than 2.6 volts with no current flowing in the motor circuit.
MEMORY RECALL <b>NO</b>	<b>CORRECTIVE ACTIONS</b>	<b><u>TROUBLE-SHOOTING DIAGRAM</u></b>          <b>NO GRAPHIC FOR THIS STATUS CODE</b>
Circuits valid for Traction Controller	<p><b><u>SYMPTOM</u></b> Control will not operate.</p> <p><b><u>POSSIBLE CAUSE</u></b> Defective control.</p> <ul style="list-style-type: none"> <li>• Replace controller unit.</li> </ul>	

TRACTION STATUS CODE	DESCRIPTION OF STATUS	CAUSE OF STATUS INDICATION
<b>-43</b>	Motor armature offset voltage is too low.	This status code will be displayed when the voltage at the current sensor input is less than 2.4 volts with no current flowing in the motor circuit.
MEMORY RECALL <b>NO</b>	<b>CORRECTIVE ACTIONS</b>	<b><u>TROUBLE-SHOOTING DIAGRAM</u></b>
Circuits valid for Traction Controller	<p><b><u>SYMPTOM</u></b> Control will not operate.</p> <p><b><u>POSSIBLE CAUSE</u></b> Defective control.</p> <ul style="list-style-type: none"> <li>• Replace controller unit.</li> </ul>	<p><b>NO GRAPHIC FOR THIS STATUS CODE</b></p>

TRACTION STATUS CODE	DESCRIPTION OF STATUS	CAUSE OF STATUS INDICATION
<b>-44</b>	Armature transistor did not turn off properly.	This status code will be displayed when, during control operation, the armature transistor fails to turn off. This will result in a PMT condition.
MEMORY RECALL <b>YES</b>	<b>CORRECTIVE ACTIONS</b>	<b><u>TROUBLE-SHOOTING DIAGRAM</u></b>
Circuits valid for Traction Controller	<p><b><u>SYMPTOM</u></b> Line contactor opens and closes, then can only be closed by opening and closing the key switch.</p> <p><b><u>POSSIBLE CAUSE</u></b> Defective control.</p> <ul style="list-style-type: none"> <li>• Replace controller unit.</li> </ul>	

TRACTION STATUS CODE	DESCRIPTION OF STATUS	CAUSE OF STATUS INDICATION
<b>-45</b>	Armature transistor did not turn on properly.	This status code will be displayed when, during control operation, the armature transistor fails to turn on properly. This will result in a PMT condition.
MEMORY RECALL <b>YES</b>	<b>CORRECTIVE ACTIONS</b>	<b><u>TROUBLE-SHOOTING DIAGRAM</u></b>
Circuits valid for Traction Controller	<p><b><u>SYMPTOM</u></b> Line contactor open and closes, then can only be closed by opening and closing the key switch.</p> <p><b><u>POSSIBLE CAUSE</u></b> Defective control. • Replace controller unit.</p>	

TRACTION STATUS CODE	DESCRIPTION OF STATUS	CAUSE OF STATUS INDICATION
<b>-46</b>	"Look Ahead" test for A2 volts less than 12% of battery volts.	This status code will be displayed when the voltage at A2 is less than 12% of battery volts.
MEMORY RECALL <b>NO</b>	<b>CORRECTIVE ACTIONS</b>	<b><u>TROUBLE-SHOOTING DIAGRAM</u></b>
Circuits valid for Traction Controller	<p><b><u>SYMPTOM</u></b> Line contactor will not pick up.</p> <p><b><u>POSSIBLE CAUSE</u></b> Check for short circuit from the motor armature to the frame of the vehicle.</p> <p>Defective control. • Replace controller unit.</p>	

TRACTION STATUS CODE	DESCRIPTION OF STATUS	CAUSE OF STATUS INDICATION
<b>-49</b>	Motor field current is too low during the run mode.	This status code will be displayed when the armature current is greater than 100A or the voltage input from the current sensor for field current is less than 1.13 V for more than 1.15 seconds.
MEMORY RECALL <b>YES</b>	<b>CORRECTIVE ACTIONS</b>	<b><u>TROUBLE-SHOOTING DIAGRAM</u></b>
Circuits valid for Traction Controller	<p><b><u>SYMPTOM</u></b> Control will not operate.</p> <p><b><u>POSSIBLE CAUSE</u></b> Defective control.</p> <ul style="list-style-type: none"> <li>• Replace controller unit.</li> </ul>	<p><b>NO GRAPHIC FOR THIS STATUS CODE</b></p>

TRACTION STATUS CODE	DESCRIPTION OF STATUS	CAUSE OF STATUS INDICATION
<b>-51</b>	Capacitor volts are low before the line contactor closes.	This status code will be displayed during "key on" when the capacitor volts is less than 85% of battery volts at initial key switch on.
MEMORY RECALL <b>NO</b>	<b>CORRECTIVE ACTIONS</b>	<b><u>TROUBLE-SHOOTING DIAGRAM</u></b>
Circuits valid for Traction Controller	<p><b><u>SYMPTOM</u></b> Line contactor does not close when capacitor does not precharge.</p> <p><b><u>POSSIBLE CAUSE</u></b> Defective control fuse.</p> <ul style="list-style-type: none"> <li>• Check control fuse for open circuit. Replace fuse, if necessary.</li> </ul> <p>Defective control.</p> <ul style="list-style-type: none"> <li>• Replace controller unit.</li> </ul>	<p>The diagram shows a battery connected to a line through a fuse (FU). The line passes through a KEY SW. and a BRAKE SW. to terminal P1. From P1, it goes to terminal P2, then through a REV. JOG SW. to terminal P3. From P3, it goes to terminal P4, then through a HIGH SPEED and EASY PICK SEL. switch to terminal P5. From P5, it goes to terminal P6, then through a FLDG. SW. to terminal P7. From P7, it goes to terminal P8, then through a REV. SW. to terminal P9. From P9, it goes to terminal P10, then through a LIFT SW. to terminal P11. From P11, it goes to terminal P12, then through a PLUG PL2 to terminal P13. From P13, it goes to terminal P14, then through a LOW BATTERY ALARM* to terminal P15. From P15, it goes to terminal P16, then through a TRAVEL/BACKUP ALARM to terminal P17. From P17, it goes to terminal P18, then through a 12V source to terminal P19. The battery is connected to terminals POS (A1) and NEG (A2). The line is connected to terminal F1. The field current sensor is connected to terminals A1 and A2. The armature is connected to terminals F1 and F2.</p>

TRACTION STATUS CODE	DESCRIPTION OF STATUS	CAUSE OF STATUS INDICATION
<b>-57</b>	Controller "motor current sensor" input too low during running.	This status code will be displayed when the voltage input from the current sensor is too low (less than 0.4V).
MEMORY RECALL <b>YES</b>	<b>CORRECTIVE ACTIONS</b>	<b><u>TROUBLE-SHOOTING DIAGRAM</u></b>
Circuits valid for Traction Controller	<p><b><u>SYMPTOM</u></b> Control will not operate.</p> <p><b><u>POSSIBLE CAUSE</u></b> Line contactor tips bouncing open during running</p> <ul style="list-style-type: none"> <li>• Visually inspect tips and clean with solvent</li> <li>• Check coil voltage</li> <li>• Confirm that correct coil is installed in contactor</li> </ul>	<p><b>NO GRAPHIC FOR THIS STATUS CODE</b></p>

TRACTION STATUS CODE	DESCRIPTION OF STATUS	CAUSE OF STATUS INDICATION
<b>-76</b>	Capacitor (1C) voltage too high.	This status code will be displayed when the voltage on the capacitor goes above 60V during the regenerative braking cycle.
MEMORY RECALL <b>YES</b>	<b>CORRECTIVE ACTIONS</b>	<b><u>TROUBLE-SHOOTING DIAGRAM</u></b>
Circuits valid for Traction Controller	<p><b><u>SYMPTOM</u></b> Line contactor opens and closes, then opens and can only close by opening and closing the key switch.</p> <p><b><u>POSSIBLE CAUSE</u></b></p> <ul style="list-style-type: none"> <li>• Unplugging the battery connector during regenerative braking.</li> <li>• Line contactor bouncing open during regen.</li> <li>• Main power fuse opening during regen.</li> <li>• Intermittent battery plug connection.</li> </ul>	<p>The diagram shows the electrical system for the traction controller. It includes a BATTERY (POS and NEG), a LINE with a FUSE (FU), and a FIELD ARMATURE. The power connections (A1, A2, F1, F2) are linked to the battery and the field armature. Control switches include KEY SW, BRAKE SW, LIFT SW, REV JOG SW, HIGH SPEED, EASY PICK, and REV SW. The diagram also shows a PLUG PL2, an ACC POT, and two 12V ALARMS (LOW BATTERY ALARM and TRAVEL/BACKUP ALARM). Terminals P1 through P18 are labeled for connection points.</p>

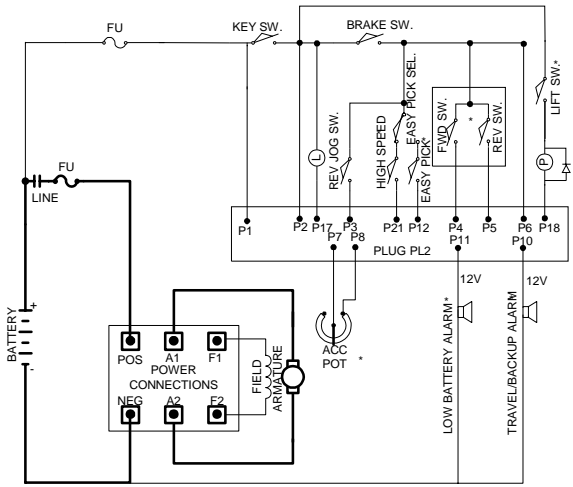

TRACTION STATUS CODE	DESCRIPTION OF STATUS	CAUSE OF STATUS INDICATION
<b>-77</b>	Motor current is detected during regenerative braking.	This status code will be displayed when motoring current ( $I_A > 200A$ ) is detected during the regen braking cycle.
MEMORY RECALL <b>YES</b>	<b>CORRECTIVE ACTIONS</b>	<b><u>TROUBLE-SHOOTING DIAGRAM</u></b>
Circuits valid for Traction Controller	<p><b><u>SYMPTOM</u></b> Line contactor opens and closes, then opens and can only close by opening and closing the key switch.</p> <p><b><u>POSSIBLE CAUSE</u></b> Defective control.</p> <ul style="list-style-type: none"> <li>• Replace controller unit</li> </ul>	

TRACTION STATUS CODE	DESCRIPTION OF STATUS	CAUSE OF STATUS INDICATION
<b>-99</b>	Maintenance alert and speed limit.	This status code will be displayed when the “normal” hour meter exceeds the “maintenance alert hours” setting for the vehicle.
MEMORY RECALL <b>YES</b>	<b>CORRECTIVE ACTIONS</b>	<b><u>TROUBLE-SHOOTING DIAGRAM</u></b>
Circuits valid for Traction Controller	<p><b><u>SYMPTOM</u></b> Status code is displayed for 4 seconds when the key switch is first turned on, and/or the vehicle may run at a reduced speed.</p> <p><b><u>CUSTOMER SELECTED SETTING WITH THE HANDSET:</u></b> User defined status code is displayed when the normal hour meter reading exceeds the programmed “maintenance alert hours” setting selected by the user.</p> <ul style="list-style-type: none"> <li>• Maintenance Code Hour Meter, Functions 19 and 20, are programmed with the Handset and command the display of status code -99.</li> <li>• If desired, Maintenance Code Speed Limit, Function 21, can be programmed with the Handset.</li> </ul> <p>User should perform the desired maintenance function. Re-set maintenance alert hour meter after maintenance is performed.</p>	<p><b>NO GRAPHIC AVAILABLE FOR THIS STATUS CODE</b></p> <p><b>USER SHOULD PERFORM THE DESIRED MAINTENANCE FUNCTION</b></p>

## Section 5. SX FAMILY GE HANDSET INSTRUCTIONS

### Section 5.1 General Features

The GE Handset is a multi-functional tool to be used with the LX, ZX, and SX Series GE solid-state controls. The Handset consists of a Light Emitting Diode (LED) display and a keyboard for data entry.

**Note: The Handset is the same for all GE controls, however, the cable will change between some control types.**

### Section 5.2 Purpose / Setup Functions

The purpose of the Handset is to allow authorized personnel to perform the following functions of the SX family of Controls:

- Monitor existing system fault codes
- Monitor intermittent random fault codes
- Monitor battery state of charge on systems with BDI
- Monitor hourmeter reading
- Monitor or adjust the following control functions:
  - ◆ Creep speed
  - ◆ Armature Controlled Acceleration and 1A Time
  - ◆ Regenerative Braking Current Limit and Disable
  - ◆ Armature and Field Current Limit
  - ◆ Plugging Distance (Current)
  - ◆ Pedal Position Plug Range or Disable
  - ◆ 1A Drop Out Current or Disable
  - ◆ Speed Limit Points
  - ◆ Truck Management Fault Speed Limit
  - ◆ Internal Resistance Compensation for Battery State of Charge Indication
  - ◆ Battery Voltage ( 36/48 volts is auto ranging )
  - ◆ Selection of Card Operation Type.

**Warning: Before connecting or disconnecting the Handset tool, turn off the key switch, unplug the battery and jack up the drive wheels of the vehicle.**

At the transistor control traction card, unplug the "Y plug" if the dash display is in use, and plug in the Handset to the plug location "Y" on the control card. After installing the Handset tool, plug the battery in and turn the key switch on. The following is the start-up display sequence that will occur:

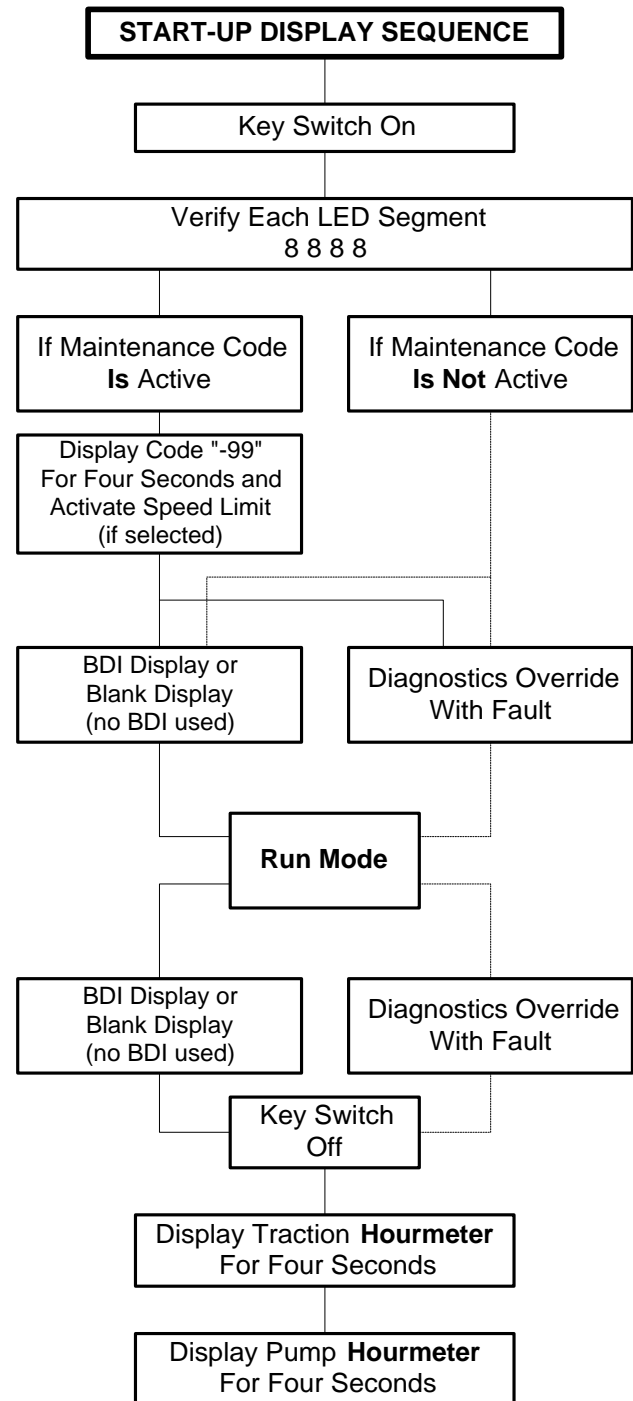

**NOTE:** The vehicle can be operated with the Handset connected, however, the adjustment knob must be set fully clockwise to insure the control operates at top speed.

**Warning:** Before making any adjustments to the control, you must consult the operating and maintenance instructions supplied by the vehicle manufacturer. Failure to follow proper set up instructions could result in mis-operation or damage to the control system.

**Section 5.3 Set-up Function Procedures**

With the Handset connected, hold down the **CONT** key and turn on the key switch. This will place you in the set-up mode, ready to monitor or adjust control function settings.

**NOTE:** The term "Push" means to depress key for approximately one second.

**Section 5.3.1 Setup Mode**

**SET-UP MODE**

ACTION	DISPLAY SHOWS	REMARKS
Hold Down CONT And Turn On Key	<b>8 8 8 8</b>	Segment Check Displayed
Push Function Number	<b>U 0 0 5</b>	Selected Function No. Is Displayed
After One Second Time Delay	<b>0 8 5</b>	Stored Value For The Function Is Displayed
Push CONT	<b>0 8 5</b>	Display Value Will Blink
Change Value With Adjustment Knob	<b>1 2 5</b>	Value Changes While Blinking
Push STORE	<b>1 2 5</b>	New Value Stored And Blinking Stops
Push ESC	<b>8 8 8 8</b>	Segment Check Displayed

At this point, another function can be monitored/changed by pushing another function number, or the vehicle can be placed in the run mode by holding the **ESC** key down for one second or longer. The display will return to either the diagnostics mode, the BDI display, or a blank display (if BDI is not used and there are no fault codes). The vehicle can now be operated with the Handset connected, or the Handset can be disconnected before operation.

**NOTE:** You can return to the segment check mode at any time, by holding down the **ESC** key until 8888 appears in the display.

**Section 5.3.2 Status Code Scrolling**

The SX family of controllers furnishes a function register that contains the last 16 "stored status codes" that shut down vehicle operation (a PMT type fault that is reset by cycling the key switch) and the battery state of charge reading at the time the fault occurred. The first of the 16

status codes will be overwritten each time a new status code occurs. This stored status code register can be cleared from memory by using the Handset.

**ACCESSING STORED STATUS CODES WITH GE HANDSET**

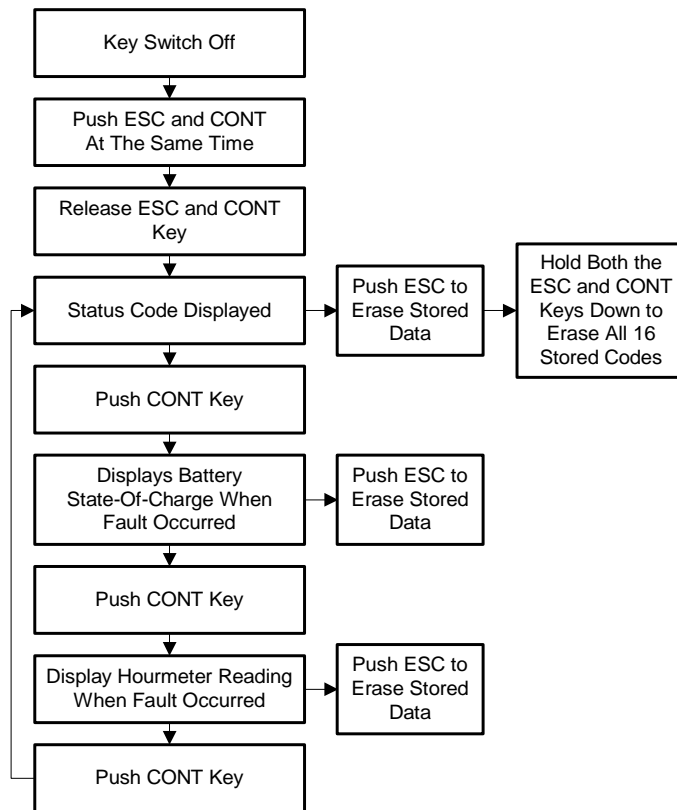

**Section 5.3.3 SX Family Handset, Plug Connections and Outline Drawing**

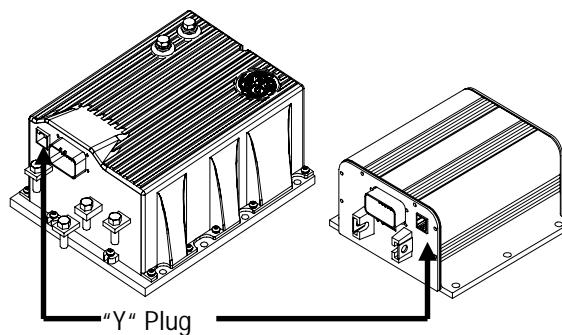

Handset Cable Part Number - 325B1002G1 (12 pin plug)  
Handset Part Number - IC3645LXHS1EC2 (12 pin plug)  
(includes handset, cable and case)

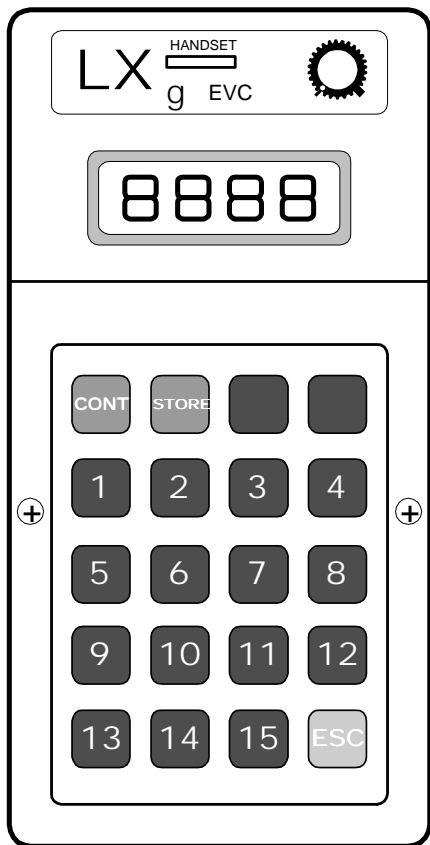

**Section 5.4 Setup Functions for Traction Controller**

**FUNCTION 1 MODE SELECT (Push 1)**

This function allows for the selecting the controller operating mode as 1, 2, 3 or 4:

Mode	Setting
1	0 to 31
2	32 to 63
3	64 to 95
4	96 to 255

**FUNCTION 2 CREEP SPEED (Push 2)**

This function allows for the adjustment of the creep speed of the vehicle. Creep speed can be adjusted when an accelerator input voltage between 3.9 and 3.3 volts or an accelerator ohm input between 6K and 4.0K ohms is provided.

Range            2% to 15% on time  
Set                0 to 255  
Resolution      0.05% per set unit  
Example:        Setting of 20 = 3% on time

**Important Note:** This function is used to optimize motor and control performance and this setting will be determined by GE and OEM engineers at the time of vehicle development. This setting must not be changed by field personnel without the permission of the OEM.

**FUNCTION 3 ARMATURE CONTROLLED ACCELERATION (Push 3)**

This function allows for the adjustment of the rate of time it takes for the control to accelerate to 100% applied battery voltage to the motor on hard acceleration.

Range            0.1 to 25.5 seconds  
Set                0 to 255  
Resolution      0.1 seconds per set unit  
Example:        Setting of 20 = 2.0 seconds

**FUNCTION 4 ARMATURE CURRENT LIMIT (Push 4)**

This function allows for the adjustment of the armature current limit of the control. The rating of the control will determine the range of adjustment for this function. Please refer to the specification sheets and current limit curves for the control used in your vehicle.

Range            See control C/L curves  
Set                0 to 255  
Example:        0 = min. current, 255 = max. current

**FUNCTION 5 PLUGGING CURRENT LIMIT (USED ONLY IN BELLY BUTTON FUNCTION) (Push 5)**

This function allows for the adjustment of the plugging distance of the vehicle. The larger the current setting, the shorter the stopping distance.

Min	Max	Set	Resolution Per Unit Value	Example: If Set at 20
55	455	0 to 255	1.57 amps	86.4 amps

**FUNCTION 6 BUZZER SELECT (Push 6)**

Setting this function to any value greater than 128 sets the buzzer to "ON" in either direction. Setting this function to any value less than 128 sets the buzzer to "ON" only in reverse.

**FUNCTION 7 MINIMUM FIELD CURRENT**

This function is set by mode settings 48, 52, 56, and 60.

**FUNCTION 8 MAX FIELD CURRENT (Push 8)**

This function allows for the adjustment of the maximum field current in order to obtain the maximum torque of the motor.

Min	Max	Set	Resolution Per Unit Value	Example: If Set at 71
0	40	51 to 255	0.185 amps	3.7 amps

**Important Note:** This function is used to optimize motor and control performance, and this setting will be determined by GE and OEM engineers at the time of vehicle development. This setting must not be changed by field personnel without the permission of the OEM.

**FUNCTION 9 REGEN BRAKING CURRENT LIMIT**

This function is set by mode settings 51, 55, 59, and 63.

**FUNCTION 10 FIELD CURRENT FOR REGEN AND PLUG BRAKING (Push 10)**

This function allows for the adjustment of the field current to be used during the regen and plug braking modes.

Min	Max	Set	Resolution Per unit value	Example If set at 71
0	40	51 to 255	.185 amps	3.7 amps

**Important Note:** This function is used to optimize motor and control performance and this setting will be determined by GE and OEM engineers at the time of vehicle development. This setting must not be changed by field personnel without the permission of the OEM.

**FUNCTION 11 MAINTENANCE CODE SPEED LIMIT (Push 11)**

This function allows for the adjustment of the speed limit (maximum battery volts to the motor) when the maintenance code is activated by the control card.

Range	100% to 0% of battery volts
Set	51 to 180
Resolution	0.78% per set unit
Example	Setting of 71 = 84% of battery volts

**FUNCTION 12 WALK SPEED LIMIT (Push 12)**

This function allows for the adjustment of the speed limit (maximum battery volts to the motor) when the jack rabbit speed limit switch is open.

Range	100% to 0% of battery volts
Set	51 to 180
Resolution	0.78% per set unit
Example	Setting of 71 = 84% of battery volts

**FUNCTION 13 FORKS FORWARD SPEED LIMIT (Push 13)**

This function allows for the adjustment of the forks forward speed limit (maximum battery volts to the motor) when the jack rabbit speed limit switch is closed and the reverse switch is closed.

Range	100% to 0% of battery volts
Set	51 to 180
Resolution	0.78% per set unit
Example	Setting of 71 = 84% of battery volts

**FUNCTION 14 INTERNAL RESISTANCE COMPENSATION (Push 14)**

This function is used when the Battery Discharge Indicator is present. Adjustment of this function will improve the accuracy of the BDI. In order to determine this setting the voltage drop of the battery under load must first be calculated by the following method.

1. On a fully charged battery, record the open circuit voltage ( $V_o$ ) by measuring the voltage at the control positive and negative power terminals.
2. Load the traction motor to 100 amps, and record the voltage ( $V_L$ ) at the control positive and negative power terminal.
3. Calculate voltage drop ( $V_{Drop}$ ) as follows:  
$$V_{Drop} = V_o - V_L$$
4. Use the table below to determine the appropriate setting using the calculated  $V_{Drop}$  as a reference.

**INTERNAL RESISTANCE COMPENSATION  
TABLE**

Setting	V <sub>Drop</sub>	Setting	V <sub>Drop</sub>
2	11.44	17	01.34
3	07.60	18	01.27
4	05.72	19	01.20
5	04.57	20	01.14
6	03.81	21	01.09
7	03.27	22	01.04
8	02.86	23	00.99
9	02.54	24	00.95
10	02.28	25	00.91
11	02.08	26	00.88
12	01.90	27	00.85
13	01.76	28	00.82
14	01.63	29	00.79
15	01.52	30	00.76
16	01.43	31	00.74

**FUNCTION 15 BATTERY VOLTS  
(Push I5)**

This function allows for the adjustment of voltage range for controls equipped with the Battery Discharge Indication function. In order for the BDI to operate properly, the setting as shown in the table must be entered:

Battery volts	Set units
24 volts	Between 0 and 31
36 volts	Between 32 and 44

*The following functions have function numbers larger than the numbers on the Handset keyboard. To access these functions. Push the CONT key and the number shown in the following instructions at the same time. THE BRAKE SWITCH MUST BE OPEN.*

**FUNCTION 16 PEDAL POSITION PLUG AND REGEN  
( Push CONT 1)**

This function allows for the adjustment of the pedal position braking. Pedal position will reduce the braking current to the current value set by this function as the accelerator is returned to the creep speed position. Maximum current is obtained with the accelerator in the top speed position.

Min	Max	Set	Resolution Per unit value	Example If set at 100
45	207	0 to 255	0.8125 per unit	81.25 amps

**FUNCTION 17 CARD TYPE SELECTION  
( Push CONT 2 )**

This function allows for the selection of the card type used for your vehicle's application. The table below shows the setting to select card application type, depending on which control card is used.

Setting	Autobrake	Jog Switch	Pot Type	Rollback
0 to 16	No	No	5K to 0 Ω	No
17 to 32	Yes	No	5K to 0 Ω	No
33 to 48	No	Yes	5K to 0 Ω	No
49 to 64	Yes	Yes	5K to 0 Ω	No
65 to 80	No	No	5K to 0 Ω	Yes
81 to 96	Yes	No	5K to 0 Ω	Yes
97 to 112	No	Yes	5K to 0 Ω	Yes
113 to 127	Yes	Yes	5K to 0 Ω	Yes

Settings for these functions should be made within the ranges indicated above.

**Warning: These settings must be changed by authorized personnel only, following instructions supplied by the vehicle manufacturer. Card type selection must be made within the capabilities of the control panel used and the supporting electro mechanical devices. Failure to comply with proper application standards could result in mis-operation or damage to the control and/or motors.**

**FUNCTION 18 HIGH SPEED SWITCH DELAY  
(Push CONT 3)**

This function allows for the adjustment of the high speed switch delay, when the switch is open.

Range	0 to 25.5 seconds
Set	0 to 255
Resolution	0.1 second per unit
Example	Setting of 100 = 10 seconds

**FUNCTION 19 MAINTENANCE CODE TENS AND UNITS  
HOURS SET  
( Push CONT 4 )**

This function allows for the adjustment of the tens and units hours of the maintenance code activation time.

Range	0 to 99
Set	0 to 99
Example	9999 Hours

**FUNCTION 20 MAINTENANCE CODE THOUSANDS AND HUNDREDS HOURS SET (Push CONT 5)**

This function allows for the adjustment of the thousands and hundreds hours of the maintenance code activation time.

Range 0 to 99  
Set 0 to 99  
Example 9999 Hours

**FUNCTION 21 PUMP ENABLE (Push CONT 6)**

This function enables or disables the BDI lift interrupt feature, which can be selected to occur at 9% battery state of charge.

Setting	Description
0 to 127	Enables BDI lift interrupt feature
128 to 255	Disables the BDI lift interrupt feature

**FUNCTION 22 TRUCK TYPE AND FUNCTIONALITY (Push CONT 7)**

This function allows the correct configuration of the truck as either a center ride or tugger vehicle. When the setting is above 128, it is configured as a tugger, and when it is set to a value of less than 128, it is configured as a center ride. Secondly the adjustment of function 1 specifies the vehicle functionality within that classification, as detailed below.

Tugger (Function 22 > 128)							
Function 1 Setting	Auto Brake	Rev Jog	Easy Pick	Roll Back	Neut Field V	Stat Code 05	Stat Code 06
0 - 16	N	Y	N	N	OFF	Y	Y
17 - 32	Y	Y	N	N	OFF	Y	Y
33 - 48	N	Y	Y	N	OFF	Y	Y
49 - 64	Y	Y	Y	N	OFF	Y	Y
65 - 80	N	Y	N	Y	ON	Y	Y
81 - 96	Y	Y	N	Y	ON	Y	Y
97 - 112	N	Y	Y	Y	ON	Y	Y
113 - 127	Y	Y	Y	Y	ON	Y	Y
Center Ride (Function 22 < 128)							
0 - 16	N	Y	N	N	OFF	Y	Y
17 - 32	Y	Y	N	N	OFF	Y	Y
33 - 48	N	Y	Y	N	OFF	Y	Y
49 - 64	Y	Y	Y	N	OFF	Y	Y
65 - 80	N	Y	N	Y	ON	Y	Y
81 - 96	Y	Y	N	Y	ON	Y	Y
97 - 112	N	Y	Y	Y	ON	Y	Y
113 - 127	Y	Y	Y	Y	ON	Y	Y

**FUNCTION 23 MOTOR CURRENT DECAY RATE (Push CONT 8)**

This function allows for the adjustment of the rate of decay of motor current after a neutral signal is received.

Range 0.1 to 1.6 seconds  
Set 0 to 16  
Resolution 0.1 seconds per set unit  
Example: Setting of 10 = 1.0 second

**FUNCTION 24 FIELD WEAKENING START (Push CONT 9)**

This function is set by mode settings 49, 53, 57, and 61.

**FUNCTION 25 MONITOR (Push CONT 10)**

This function allows the monitoring of certain control functions by looking directly at the RAM of the microprocessor. Because absolute memory locations need to be known, this function should not be used without detailed instructions from the GE application engineer.

**This function should only be adjusted by the vehicle OEM. To ensure optimum operation of the control, this function must be left with zero stored in this register.**

**FUNCTION 26 RATIO (Push CONT 11)**

This function is set by mode settings 50, 54, 58, and 62.

**FUNCTION 27 NOT APPLICABLE**

This function is not applicable to this controller type and should not be adjusted.

**FUNCTION 28 STORED STATUS CODE COUNT POINTER (Push CONT 13)**

This register contains the location of the last stored status code recorded of the 16 stored status codes. These stored status codes have caused a PMT controller shutdown and/or disruption of normal vehicle operation.

To determine which stored status code was the last one recorded, read the number stored in Function 28. Using the **Memory Map** for your logic card, match the "**stored status code pointer number**" [the number shown in (*bold italics*) in the HS (Handset) number column] on the memory map, with the number obtained from Function 28. This will be the last stored status code recorded.

Note: When scrolling through the stored status code register, the register always starts at status code 1 and scrolls to status code 16. Instructions for scrolling the register are in section 5.3.2 of this instruction booklet.

**FUNCTION 29 HOUR METER TENS AND UNITS HOURS SET ( Push CONT 14 )**

This function allows for the adjustment of the tens and units hours of the displayed hour meter.

Range	0 to 99
Set	0 to 99
Example	9999 Hours

**FUNCTION 30 HOUR METER THOUSANDS AND HUNDREDS HOURS SET ( Push CONT 15 )**

This function allows for the adjustment of the thousands and hundreds hours of the displayed hour meter.

Range	0 to 99
Set	0 to 99
Example	9999 Hours

*The following functions have function numbers larger than the numbers on the Handset keyboard. To access these functions. Push the CONT key and the number shown in the following instructions at the same time. THE BRAKE SWITCH MUST BE CLOSED.*

**FUNCTION 48 MODE 1 MIN FIELD CURRENT ( Push CONT 1 )**

This function allows the adjustment of the field weakening level in order to set the top speed of the motor.

Min	Max	Set	Resolution Per Unit Value	Example If Set at 71
0	40	51 to 255	0.185 amps	3.7 amps

**Important Note:** This function is used to optimize motor and control performance, and this setting will be determined by GE and OEM engineers at the time of vehicle development. This setting must not be changed by field personnel without the permission of the OEM.

This MIN FIELD CURRENT takes effect when the Mode 1 settings are selected by Function 1.

**FUNCTION 49 MODE 1 FIELD WEAKENING START ( Push CONT 2 )**

This function allows for setting the armature current at which minimum field current will be achieved.

Range	0 to 240 Amps
Setting	0 to 147
Resolution	1.625 per set unit
Example	Setting of 20 = 32.5 amps

$$I_{M FWS} = VAL \times 1.625$$

**Important Note:** This function is used to optimize motor and control performance and this setting will be determined by GE and OEM engineers at the time of vehicle development. This setting must not be changed by field personnel without the permission of the OEM.

This FIELD WEAKENING START takes effect when the Mode 1 settings are selected by Function 1.

**FUNCTION 50 MODE 1 RATIO ( Push CONT 3 )**

This function sets the ratio between armature and field current when transitioning from minimum field to maximum field current. The setting represents the quantity of field current changed for each 100 amps of armature current changed.

Max Fld Ref	Set	Resolution Per Unit Value	Example If Set at 5
40	0 to 10	2.85 amps	14.25 amps

This RATIO takes effect when the Mode 1 settings are selected by Function 1.

**FUNCTION 51 MODE 1 REGEN BRAKING C/L ( Push CONT 4 )**

This function allows for the adjustment of the Regen braking current limit. The higher the current, the shorter the stopping distance.

Min	Max	Set	Resolution Per unit value	Example If set at 20
52	468	0 to 255	1.63 amps	84.6 amps

This REGEN BRAKING C/L takes effect when the Mode 1 settings are selected by Function 1.



**FUNCTION 52    MODE 2 MIN FIELD CURRENT**  
**( Push CONT 5 )**

Same as Function 48.

This MIN FIELD CURRENT takes effect when the Mode 2 settings are selected by Function 1.

**FUNCTION 53    MODE 2 FIELD WEAKENING START**  
**( Push CONT 6 )**

Same as Function 49.

This FIELD WEAKENING START takes effect when the Mode 2 settings are selected by Function 1.

**FUNCTION 54    MODE 2 RATIO**  
**( Push CONT 7 )**

Same as Function 50.

This RATIO takes effect when the Mode 2 settings are selected by Function 1.

**FUNCTION 55    MODE 2 REGEN BRAKING C/L**  
**( Push CONT 8 )**

Same as Function 51.

This REGEN BRAKING C/L takes effect when the Mode 2 settings are selected by Function 1.

**FUNCTION 56    MODE 3 MIN FIELD CURRENT**  
**( Push CONT 9 )**

Same as Function 48.

This MIN FIELD CURRENT takes effect when the Mode 3 settings are selected by Function 1.

**FUNCTION 57    MODE 3 FIELD WEAKENING START**  
**( Push CONT 10 )**

Same as Function 49.

This FIELD WEAKENING START takes effect when the Mode 3 settings are selected by Function 1.

**FUNCTION 58    MODE 3 RATIO**  
**( Push CONT 11 )**

Same as Function 50.

This RATIO takes effect when the Mode 3 settings are selected by Function 1.

**FUNCTION 59    MODE 3 REGEN BRAKING C/L**  
**( Push CONT 12 )**

Same as Function 51.

This REGEN BRAKING C/L takes effect when the Mode 3 settings are selected by Function 1.

**FUNCTION 60    MODE 4 MIN FIELD CURRENT**  
**( Push CONT 13 )**

Same as Function 48.

This MIN FIELD CURRENT takes effect when the Mode 4 settings are called selected by Function 1.

**FUNCTION 61    MODE 4 FIELD WEAKENING START**  
**( Push CONT 14 )**

Same as Function 49.

This FIELD WEAKENING START takes effect when the Mode 4 settings are selected by Function 1.

**FUNCTION 62    MODE 4 RATIO**  
**( Push CONT 15 )**

Same as Function 50.

This RATIO takes effect when the Mode 4 settings are selected by Function 1.

**FUNCTION 63    MODE 4 REGEN BRAKING C/L**  
**( Push CONT ESC )**

Same as Function 51.

This REGEN BRAKING C/L takes effect when the Mode 4 settings are selected by Function 1.

Section 5.5 Summary of Current Limit Adjustments

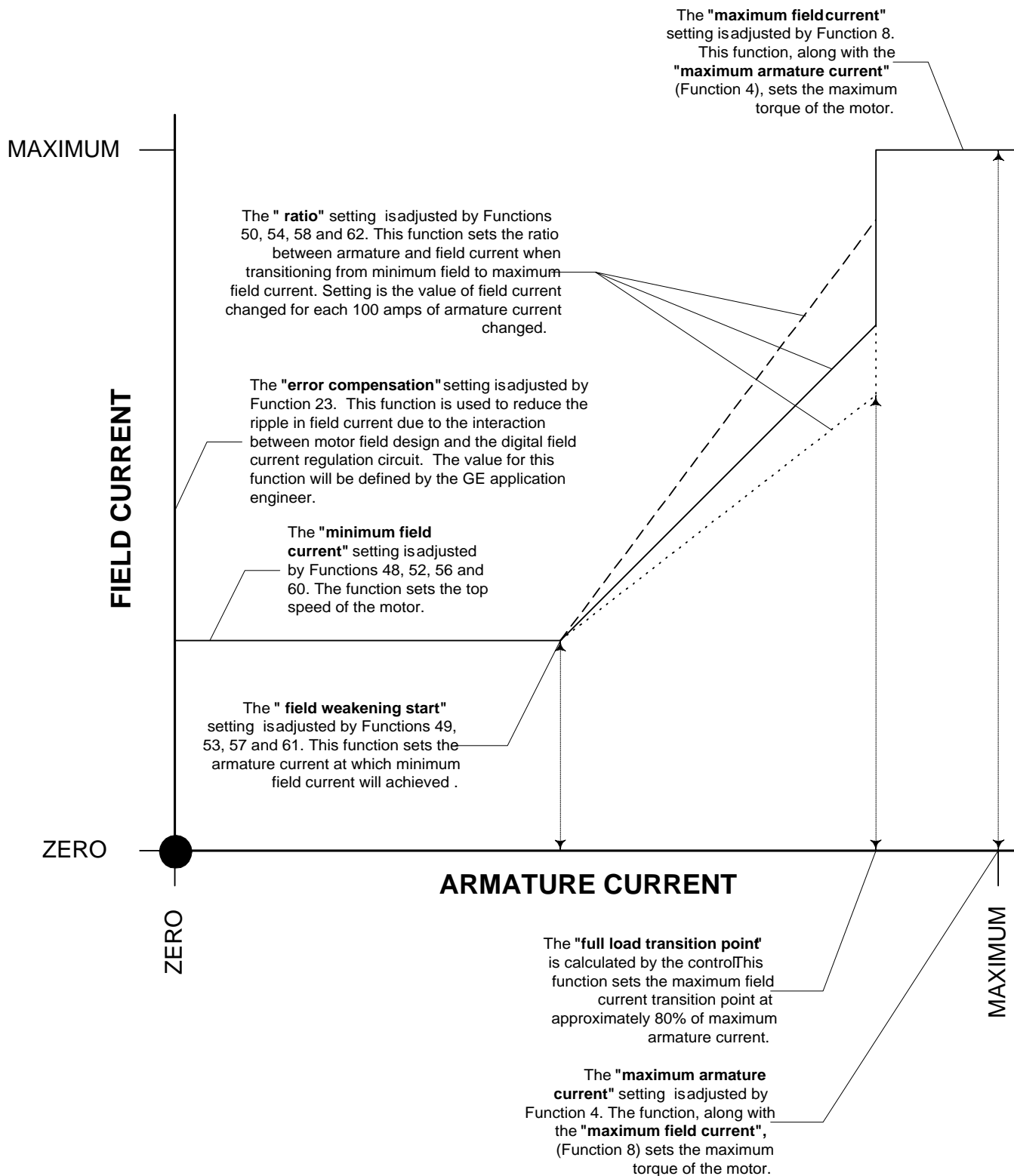

**Section 6.0 DASH DISPLAYS**

**Section 6.1 Application**

The SX family Standard and Interactive Dash Displays allow the operator and maintenance personnel easy access to truck operation information and real-time system diagnostics of the controller, motor and various accessories. Hourmeter readings, battery discharge information, maintenance information and system status codes are clearly displayed during startup and running modes. Shielded cable connections are made to the Dash Display by means of five (5) 22-gage wires to the "Y" Plug of the traction and hydraulic pump controls.

**Section 6.2 Standard Dash Displays**

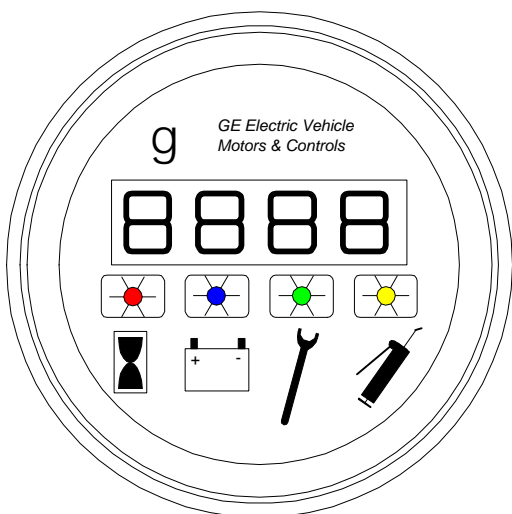

The GE Standard Dash Display is a four segment Light Emitting Diode (LED) instrument that displays the GE LX, ZX, and SX Status Codes, Hourmeter Readings, Battery Discharge Indication, and Maintenance Required Code. The four LED's above the symbols indicate the active readout mode.

**Section 6.2.1 Connections**

Connections are made to the Dash Display with five (5) 22-gage wires to Plug "Y" of each control. Shielded cable is required to eliminate signal interference.

**Section 6.2.2 Part Number**

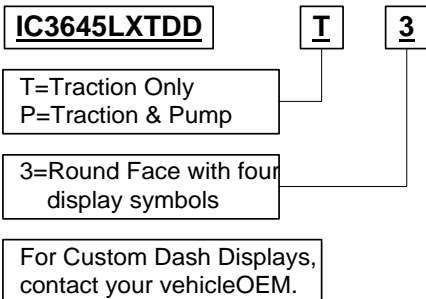

**Section 6.2.3 Connector Reference Numbers**

- AMP#102241-3 Dash Display mating plug
- AMP#1-87195-8 Dash Display mating pin
- 44A723596-G09 Dash Display plug kit
- AMP#175965-2 "Y" Plug
- AMP#175180-1 "Y" Plug receptacle

**Section 6.3 Start-Up Display Sequence**

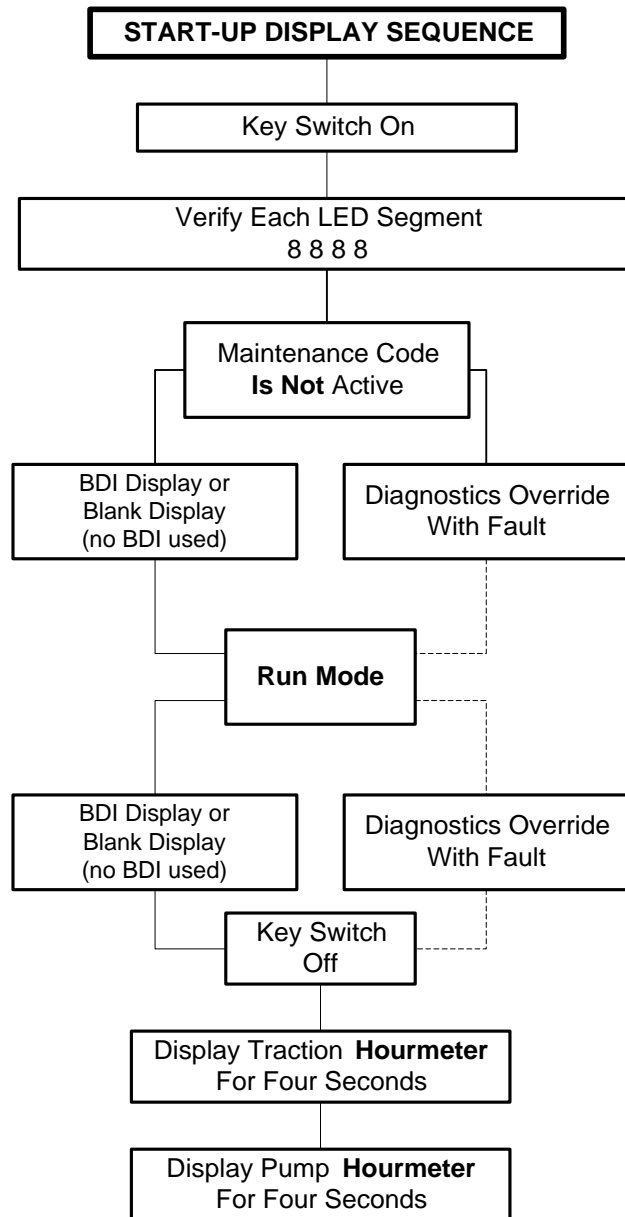

**Section 6.4 Outline Drawings**

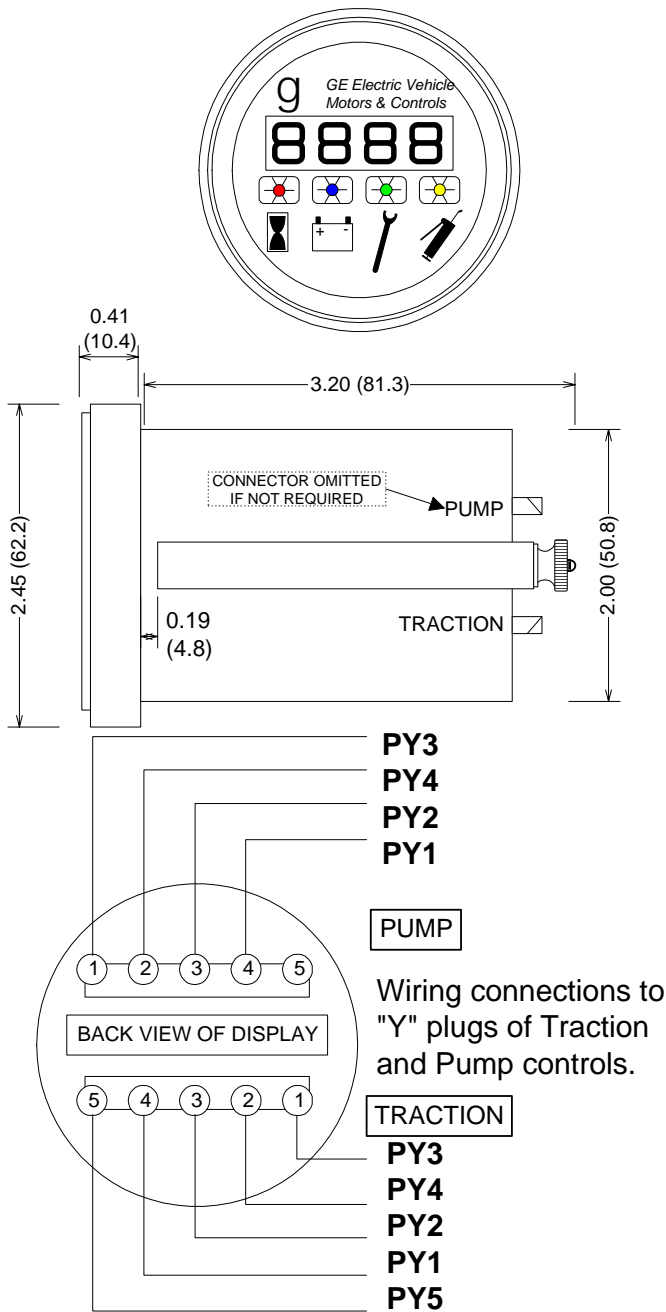

Section 7.0 MEMORY MAPS

Section 7.1 Traction Control

E <sup>2</sup>	Func No.	HS No.	Traction Control Function	Access By	Restrictions
0	1	1	Mode Select	HS or PC	None
1	2	2	Creep Speed	HS or PC	None
2	3	3	Armature Controlled Acceleration	HS or PC	None
3	4	4	Armature Current Limit	HS or PC	None
4	5	5	Plugging Current Limit	HS or PC	None
5	6	6	Buzzer	HS or PC	None
6	7	7	Minimum field	HS or PC	Value from mode
7	8	8	Max Field Current	HS or PC	None
8	9	9	Regen current limit	HS or PC	Value from mode
9	10	10	Field Current for Regen and Plug Braking	HS or PC	None
10	11	11	Maintenance Code Speed Limit and Low Battery	HS or PC	None
11	12	12	Not applicable	HS or PC	None
12	13	13	Forks Top Speed Limit in Reverse	HS or PC	None
13	14	14	IR Compensation	HS or PC	None
14	15	15	Battery Volts Select	HS or PC	None
15	16	16	Pedal Position Plug and Regen	HS or PC	None
16	17	17	Card Type Selection	HS or PC	None
17	18	18	Delay High Speed Switch	HS or PC	None
18	19	19	Maintenance Code HM (Tens/Units)	HS or PC	None
19	20	20	Maintenance Code HM (Thou/Hun)	HS or PC	None
20	21	21	Pump Enable	HS or PC	None
21	22	22	Truck Type and Functionality	HS or PC	> 128 selects Tugger
22	23	23	Motor Current Decay Rate	HS or PC	None
23	24	24	FW Start	HS or PC	Value from mode
24	25	25	Monitor	HS or PC	GE Temporary Storage
25	26	26	Ratio	HS or PC	Value from Mode
26	27	27	Not applicable	HS or PC	GE Temporary Storage
27	28	28	Fault Count Pointer	HS or PC	None
28	29	29	Hour Meter Tens and Units	HS or PC	None
29	30	30	Hour Meter Thousands and Hundreds	HS or PC	None
30	31		Aux HM (Tens/Ones)	PC Only	None
31	32		Aux HM (Thou/Hun)	PC Only	None
32	33	(18)	Stored Status Code #1	PC Only	Reset to Zero Only
33	34		BDI 1	PC Only	Reset to Zero Only
34	35		Hours (Tens/Ones) 1	PC Only	Reset to Zero Only
35	36		Hours (Thou/Hun) 1	PC Only	Reset to Zero Only
36	37	(20)	Stored Status Code #2	PC Only	Reset to Zero Only
37	38		BDI 2	PC Only	Reset to Zero Only
38	39		Hours (Tens/Ones) 2	PC Only	Reset to Zero Only
39	40		Hours (Thou/Hun) 2	PC Only	Reset to Zero Only
40	41	(22)	Stored Status Code #3	PC Only	Reset to Zero Only
41	42		BDI 3	PC Only	Reset to Zero Only
42	43		Hours (Tens/Ones) 3	PC Only	Reset to Zero Only

E <sup>2</sup>	Func No.	HS No.	Traction Control Function	Access By	Restrictions
43	44		Hours (Thou/Hun) 3	PC Only	Reset to Zero Only
45	46		BDI 4	PC Only	Reset to Zero Only
46	47		Hours (Tens/Ones) 4	PC Only	Reset to Zero Only
47	48		Hours (Thou/Hun) 4	PC Only	Reset to Zero Only
48	49	(26)	Stored Status Code #5	PC Only	Reset to Zero Only
49	50		BDI 5	PC Only	Reset to Zero Only
50	51		Hours (Tens/Ones) 5	PC Only	Reset to Zero Only
51	52		Hours (Thou/Hun) 5	PC Only	Reset to Zero Only
52	53	(28)	Stored Status Code #6	PC Only	Reset to Zero Only
53	54		BDI 6	PC Only	Reset to Zero Only
54	55		Hours(Tens/Ones) 6	PC Only	Reset to Zero Only
55	56		Hours(Thou/Hun) 6	PC Only	Reset to Zero Only
56	57	(30)	Stored Status Code #7	PC Only	Reset to Zero Only
57	58		BDI 7	PC Only	Reset to Zero Only
58	59		Hours(Tens/Ones) 7	PC Only	Reset to Zero Only
59	60		Hours(Thou/Hun) 7	PC Only	Reset to Zero Only
60	61	(32)	Stored Status Code #8	PC Only	Reset to Zero Only
61	62		BDI 8	PC Only	Reset to Zero Only
62	63		Hours;(Tens/Ones) 8	PC Only	Reset to Zero Only
63	64		Hours(Thou/Hun) 8	PC Only	Reset to Zero Only
64	65	(34)	Stored Status Code #9	PC Only	Reset to Zero Only
65	66		BDI 9	PC Only	Reset to Zero Only
66	67		Hours(Tens/Ones) 9	PC Only	Reset to Zero Only
67	68		Hours(Thou/Hun) 9	PC Only	Reset to Zero Only
68	69	(36)	Stored Status Code #10	PC Only	Reset to Zero Only
69	70		BDI 10	PC Only	Reset to Zero Only
70	71		Hours(Tens/Ones) 10	PC Only	Reset to Zero Only
71	72		Hours(Thou/Hun) 10	PC Only	Reset to Zero Only
72	73	(38)	Stored Status Code #11	PC Only	Reset to Zero Only
73	74		BDI 11	PC Only	Reset to Zero Only
74	75		Hours(Tens/Ones) 11	PC Only	Reset to Zero Only
75	76		Hours(Thou/Hun) 11	PC Only	Reset to Zero Only
76	77	(40)	Stored Status Code #12	PC Only	Reset to Zero Only
77	78		BDI 12	PC Only	Reset to Zero Only
78	79		Hours(Tens/Ones) 12	PC Only	Reset to Zero Only
79	80		Hours(Thou/Hun) 12	PC Only	Reset to Zero Only
80	81	(42)	Stored Status Code #13	PC Only	Reset to Zero Only
81	82		BDI 13	PC Only	Reset to Zero Only
82	83		Hours(Tens/Ones) 13	PC Only	Reset to Zero Only
83	84		Hours(Thou/Hun) 13	PC Only	Reset to Zero Only
84	85	(44)	Stored Status Code # 14	PC Only	Reset to Zero Only
85	86		BDI 14	PC Only	Reset to Zero Only
86	87		Hours(Tens/Ones) 14	PC Only	Reset to Zero Only
87	88		Hours(Thou/Hun) 14	PC Only	Reset to Zero Only
88	89	(46)	Stored Status Code # 15	PC Only	Reset to Zero Only
89	90		BDI 15	PC Only	Reset to Zero Only
90	91		Hours (Tens/Ones) 15	PC Only	Reset to Zero Only

E <sup>2</sup>	Func No.	HS No.	Traction Control Function	Access By	Restrictions
90	91		Hours (Tens/Ones) 15	PC Only	Reset to Zero Only
91	92		Hours (Thou/Hun) 15	PC Only	Reset to Zero Only
92	93	<b>(48)</b>	Stored Status Code #16	PC Only	Reset to Zero Only
94	95		Hours (Tens/Ones) 16	PC Only	Reset to Zero Only
95	96		Hours (Thou/Hun) 16	PC Only	Reset to Zero Only
96	97	48	Mode 1 Min Field Current	HS or PC	None
97	98	49	Mode 1 Field Weakening Start	HS or PC	None
98	99	50	Mode 1 Ratio	HS or PC	None
99	100	51	Mode 1 Regen Braking Current Limit	HS or PC	None
100	101	52	Mode 2 Min Field Current	HS or PC	None
101	102	53	Mode 2 Field Weakening Start	HS or PC	None
102	103	54	Mode 2 Ratio	HS or PC	None
103	104	55	Mode 2 Regen Braking Current Limit	HS or PC	None
104	105	56	Mode 3 Min Field Current	HS or PC	None
105	106	57	Mode 3 Field Weakening Start	HS or PC	None
106	107	58	Mode 3 Ratio	HS or PC	None
107	108	59	Mode 3 Regen Braking Current Limit	HS or PC	None
108	109	60	Mode 4 Min Field Current	HS or PC	None
109	110	61	Mode 4 Field Weakening Start	HS or PC	None
110	111	62	Mode 4 Ratio	HS or PC	None
111	112	63	Mode 4 Regen Braking Current Limit	HS or PC	None
112	113		Secure HM (Tens/Ones)	PC Only	OEM Read Only
113	114		Secure HM (Thou/Hun)	PC Only	OEM Read Only
114	115		Secure Aux HM (Tens/Ones)	PC Only	OEM Read Only
115	116		Secure Aux HM (Thou/Hun)	PC Only	OEM Read Only
116	117		Reserved	PC Only	GE Future Use
117	118		Reserved	PC Only	GE Future Use
118	119		Reserved	PC Only	GE Future Use
119	120		Reserved	PC Only	GE Future Use
120	121		OEM Use	PC Only	None
121	122		OEM Use	PC Only	None
122	123		OEM Use	PC Only	None
123	124		OEM Use	PC Only	None
124	125		OEM Use	PC Only	None
125	126		OEM Use	PC Only	None
126	127		OEM Use	PC Only	None
127	128		OEM Use	PC Only	None

Numbers in ***(bold italics)*** are Stored Status Code pointers.