

**SEPARATELY EXCITED TRANSISTORIZED DUAL MOTOR TRACTION CONTROL
 AND SERIES PUMP CONTROL
 INSTALLATION AND OPERATION MANUAL**
(IC3645SR4T404N11 and IC3645SP4T400N12)

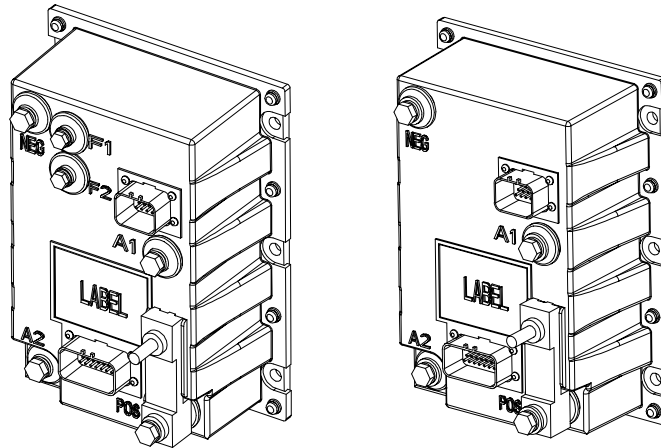

Note: The information contained herein is intended to assist OEM's, Dealers and Users of electric vehicles in the application, installation and service of GE solid-state controllers. This manual does not purport to cover all variations in OEM vehicle types. Nor does it provide for every possible contingency to be met involving vehicle installation, operation or maintenance. For additional information and/or problem resolution, please refer the matter to the OEM vehicle manufacturer through his normal field service channels. Do not contact GE directly for this assistance.

Table of Contents

General Electric Company February 2002

| | | |
|--------------------|--|----------|
| Section 1.0 | INTRODUCTION | 4 |
| 1.1 | Motor Characteristics | 4 |
| 1.2 | Solid-State Reversing | 5 |
| 1.3 | Flexible System Application..... | 5 |
| 1.4 | More Features with Fewer Components | 5 |
| | | |
| Section 2.0 | FEATURES OF IT/IP FAMILY OF MOTOR CONTROLLERS | 6 |
| 2.1 | Performance..... | 6 |
| 2.1.1 | Oscillator Card Features | 6 |
| 2.1.1.a | Standard Operation | 6 |
| 2.1.1.b | Creep Speed..... | 6 |
| 2.1.1.c | Controlled Acceleration | 6 |
| 2.1.2 | Current Limit | 6 |
| 2.1.3 | Braking..... | 6 |
| 2.1.3.a | Plug Braking | 6 |
| 2.1.3.b | Regenerative Braking to Zero Speed | 6 |
| 2.1.3.c | Pedal Position Plug Braking | 6 |
| 2.1.3.d | Auto Braking..... | 6 |
| 2.1.4 | Auxiliary Speed Control..... | 6 |
| 2.1.4.a | Field Weakening..... | 6 |
| 2.1.4.b | Speed Limits | 7 |
| 2.1.4.c | Proportional Operation for Dual Motor Vehicles | 7 |

Table of Contents (Continued)

| | | |
|--------------------|--|-----------|
| 2.1.5 | Ramp Operation | 7 |
| 2.1.5.a | Ramp Start | 7 |
| 2.1.5.b | Anti-Rollback | 7 |
| 2.1.6 | Steer Pump Contactor Time Delay | 7 |
| 2.1.7 | On-Board Coil Drivers and Internal Coil Suppression | 8 |
| 2.2 | System Protective Override | 8 |
| 2.2.1 | Static Return to Off (SRO) | 8 |
| 2.2.2 | Accelerator Volts Hold Off | 8 |
| 2.2.3 | Pulse Monitor Trip (PMT)..... | 8 |
| 2.2.4 | Thermal Protector (TP)..... | 8 |
| 2.2.5 | Low Voltage | 8 |
| 2.3 | Diagnostics..... | 8 |
| 2.3.1 | Systems Diagnostics..... | 8 |
| 2.3.2 | Status Codes..... | 8 |
| 2.3.2.a | Standard Status Codes..... | 8 |
| 2.3.2.b | Stored Status Codes | 8 |
| 2.3.3 | Hourmeter Readings | 9 |
| 2.3.3.a | Maintenance Alert and Speed Limit | 9 |
| 2.3.4 | Battery Discharge Indication (BDI)..... | 9 |
| 2.3.4.a | Internal Resistance Compensation | 9 |
| 2.3.5 | Handset | 9 |
| 2.3.6 | RS-232 Communication Port | 9 |
| 2.3.6.a | Dash Display Interaction Modes | 9 |
| 2.3.7 | Circuit Board Coil Driver Modules..... | 9 |
| 2.3.8 | Truck Management Module (TMM) | 9 |
| 2.4 | Hydraulic Pump Control..... | 10 |
| Section 3.0 | ORDERING INFORMATION, ELEMENTARY AND OUTLINE DRAWINGS..... | 11 |
| 3.1 | Ordering Information for Separately Excited Controls..... | 11 |
| 3.2 | Outline: IT400 Package Size..... | 12 |
| 3.3 | Outline: IP400 Package Size | 13 |
| 3.4 | Traction Elementary | 14 |
| 3.5 | Pump Elementary | 15 |
| 3.6 | Traction and Pump Control Input / Output List | 16 |
| Section 4.0 | TROUBLESHOOTING AND DIAGNOSTIC STATUS CODES..... | 17 |
| 4.1 | General Maintenance Instructions..... | 17 |
| 4.2 | Cable Routing and Separation | 17 |
| 4.2.1 | Application Responsibility | 17 |
| 4.2.2 | Signal/Power Level Definitions | 17 |
| 4.2.2.a | Low Level Signals (Level L) | 17 |
| 4.2.2.b | High Level Signals (Level H)..... | 18 |
| 4.2.2.c | Medium-Power Signals (Level MP) | 18 |
| 4.2.2.d | High-Power Signals (Level HP) | 18 |
| 4.2.3 | Cable Spacing Guidelines..... | 18 |
| 4.2.3.a | General Cable Spacing..... | 18 |
| 4.2.4 | Cabling for Vehicle Retrofits..... | 18 |
| 4.2.5 | RF Interference..... | 18 |
| 4.2.6 | Suppression..... | 18 |
| 4.3 | Recommended Lubrication of Pins and Sockets Prior to Installation..... | 19 |
| 4.4 | Controller Mounting Guidelines | 20 |
| 4.4.1 | Necessary Tools | 20 |

Table of Contents (Continued)

| | | |
|--------------------|--|-----------|
| 4.4.2 | The GE Control Mounting Surface..... | 20 |
| 4.4.3 | Vehicle Mounting Surface..... | 20 |
| 4.4.4 | Application of Thermal Compound..... | 20 |
| 4.4.5 | Mounting the GE Control..... | 21 |
| 4.4.6 | Maintenance..... | 21 |
| 4.5 | General Troubleshooting Instructions..... | 21-22 |
| 4.6 | Traction Controller Status Codes..... | 23-44 |
| 4.7 | TMM Status Codes..... | 45-49 |
| 4.8 | Pump Control Status Codes..... | 50-56 |
| Section 5.0 | TRUCK MANAGEMENT MODULE (TMM)..... | 57 |
| 5.1 | General Features..... | 57 |
| 5.2 | Operation..... | 57 |
| 5.3 | Installation..... | 57 |
| 5.4 | Connection Diagrams..... | 57 |
| 5.4.1 | TMM7A Card Connections..... | 57 |
| 5.4.2 | TMM7A Typical Brush Wear Sensor Connections..... | 57 |
| 5.4.3 | TMM Pump Control Connections..... | 58 |
| 5.5 | TMM7A Outline Drawings..... | 58 |
| Section 6.0 | IT FAMILY - GE HANDSET INSTRUCTIONS..... | 59 |
| 6.1 | General Features..... | 59 |
| 6.2 | Purpose/Setup Functions..... | 59 |
| 6.3 | Setup Function Procedures..... | 60 |
| 6.3.1 | Setup Mode..... | 60 |
| 6.3.2 | Status Code Scrolling..... | 60 |
| 6.3.3 | IT Handset Plug Connections & Outline Drawing..... | 60 |
| 6.4 | Setup Functions for Traction Controller .. | 61-66 |
| 6.5 | Summary of Current Limit Adjustments..... | 67 |
| 6.6 | Setup Functions for Hydraulic Pump Controller .. | 68-70 |
| Section 7.0 | DASH DISPLAYS..... | 71 |
| 7.1 | Application..... | 71 |
| 7.2 | Standard Dash Displays..... | 71 |
| 7.3 | Interactive Dash Displays..... | 71 |
| 7.4 | Start-up Display Sequence..... | 72 |
| 7.5 | Outline Drawings..... | 72 |
| Section 8.0 | TURN ANGLE POTENTIOMETER INSTALLATION..... | 73 |
| 8.1 | General..... | 73 |
| 8.2 | 320 Degree Potentiometer Input..... | 74 |
| 8.3 | Turn Angle Input Volts vs. Steer Wheel Degrees vs. Handset Readings..... | 75 |
| Section 9.0 | MEMORY MAPS..... | 76 |
| 9.1 | Traction Control..... | 76-78 |
| 9.2 | Pump Control..... | 79-81 |

Section 1. INTRODUCTION

Section 1.1 Motor Characteristics

The level of sophistication in the controllability of traction motors has changed greatly over the past several years. Vehicle manufacturers and users are continuing to expect more value and flexibility in electric vehicle motor and control systems as they are applied today. In order to respond to these market demands, traction system designers have been forced to develop new approaches to reduce cost and improve functions and features of the overall system. Development is being done in a multi-generational format that allows the market to take advantage of today's technology, while looking forward to new advances on the horizon. GE has introduced a second generation system using separately excited DC shunt wound motors. The separately excited DC motor system offers many of the features that are generally found on the advanced AC systems. Historically, most electric vehicles have relied have on series motor designs because of their ability to produce very high levels of torque at low speeds. But, as the demand for high efficiency systems increases, i.e., systems that are more closely applied to customers' specific torque requirements, shunt motors are now often being considered over series motors. In most applications, by independently controlling the field and armature currents in the separately excited motor, the best attributes of both the series and the shunt wound motors can be combined.

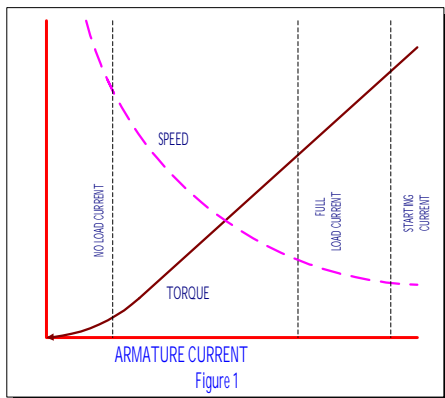

As shown in from the typical performance curves of Figure 1, the high torque at low speed characteristic of the series motor is evident.

In a shunt motor, the field is connected directly across the voltage source and is therefore independent of variations in load and armature current. If field strength is held constant, the torque developed will vary directly with the armature current. If the mechanical load on the motor increases, the motor slows down, reducing the back EMF (which depends on the speed, as well as the constant field strength). The reduced back EMF allows the armature

current to increase, providing the greater torque needed to drive the increased mechanical load. If the mechanical load is decreased, the process reverses. The motor speed and the back EMF increase, while the armature current and the torque developed decrease. Thus, whenever the load changes, the speed changes also, until the motor is again in electrical balance.

In a shunt motor, the variation of speed from no load to normal full load on level ground is less than 10%. For this reason, shunt motors are considered to be constant speed motors (Figure 2).

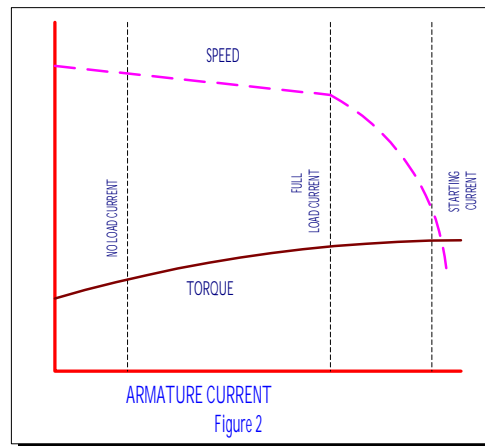

In the separately excited motor, the motor is operated as a fixed field shunt motor in the normal running range. However, when additional torque is required, for example, to climb non-level terrain, such as ramps and the like, the field current is increased to provide the higher level of torque. In most cases, the armature to field ampere turn ratio can be very similar to that of a comparable size series motor (Figure 3.)

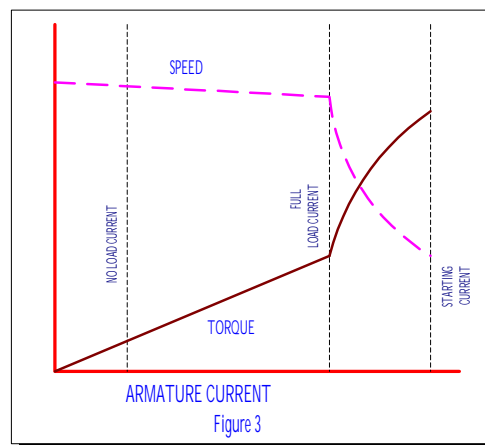

Aside from the constant horsepower characteristics described above, there are many other features that provide increased performance and lower cost. The

following description provides a brief introduction to examples of some of these features.

Section 1. 2 Solid-State Reversing

The direction of armature rotation on a shunt motor is determined by the direction in which current flows through the field windings. Because of the of the shunt motor field only typically requires about 10% of the armature current at full torque, it is normally cost effective to replace the double-pole, double-throw reversing contactor with a low power transistor H-Bridge circuit (Figure 4).

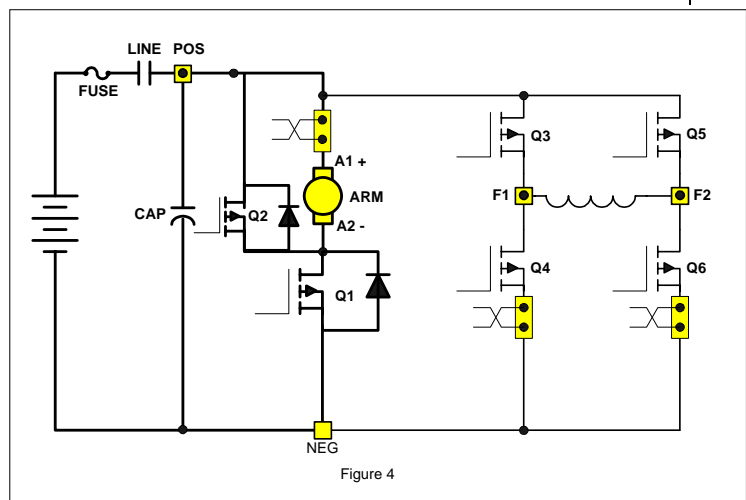

Figure 4

By energizing the transistors in pairs, current can be made to flow in either direction in the field. The armature control circuit typically operates at 12KHZ to 15KHZ, a frequency range normally above human hearing. This high frequency coupled with the elimination of directional contactors, provides very quiet vehicle operation. The field control circuits typically operate at 2 KHZ.

The line contactor is normally the only contactor required for the shunt motor traction circuit. This contactor is used for both pre-charge of the line capacitors and for emergency shut down of the motor circuit, in case of problems that would cause a full motor torque condition. The line can be energized and de-energized by the various logic combinations of the vehicle, i.e. activate on key, seat or start switch closure, and de-energize on time out of idle vehicle. Again, these options add to the quiet operation of the vehicle.

Section 1. 3 Flexible System Application

Because the shunt motor controller has the ability to control both the armature and field circuits independently, the system can normally be adjusted for maximum system efficiencies at certain operating parameters. Generally speaking, with the ability of independent field and

armature, the motor performance curve can be maximized through proper control application.

Section 1. 4 More Features with Fewer Components

Field weakening with a series wound motor is accomplished by placing a resistor in parallel with the field winding of the motor. Bypassing some of the current flowing in the field into the resistor causes the field current to be less, or weakened. With the field weakened, the motor speed will increase, giving the effect of "overdrive". To change the "overdrive speed", it is necessary to change the resistor value. In a separately excited motor, independent control of the field current provides for infinite adjustments of "overdrive" levels, between motor base speed and maximum weak field. The desirability of this feature is enhanced by the elimination of the contactor and resistor required for field weakening with a series motor.

With a separately excited motor, overhauling speed limit, or downhill speed, will also be more constant. By its nature, the shunt motor will try to maintain a constant speed downhill. This characteristic can be enhanced by increasing the field strength with the control. Overhauling load control works in just the opposite way of field weakening, armature rotation slows with the increase of current in the field.

Regenerative braking (braking energy returned to the battery) may be accomplished completely with solid-state technology. The main advantage of regenerative braking is increased motor life. Motor current is reduced by 50% or more during braking while maintaining the same braking torque as electrical braking with a diode clamp around the armature. The lower current translates into longer brush life and reduced motor heating. Solid state regenerative braking also eliminates a power diode, current sensor and contactor from the circuit.

For GE, the future is now as we make available a new generation of electric traction motor systems for electric vehicles having separately excited DC shunt motors and controls. Features that were once thought to be only available on future AC or brushless DC technology vehicles systems are now achievable and affordable.

Section 2. FEATURES OF IT/IP FAMILY OF TRANSISTOR MOTOR CONTROLLERS

Section 2.1 Performance

Section 2.1.1 Oscillator Card Features

Section 2.1.1.a Standard Operation

With the accelerator at maximum ohms or volts, the creep speed can be adjusted by Function 2 of the Handset or a trimpot. The field control section allows the adjustment of the field weakening level in order to set the top speed of the motor. This top speed function (Minimum Field Current) is enabled when the armature current is less than the value set by Function 24 and the accelerator input voltage is less than 1 volt. Top Speed can be adjusted by Function 7 of the Handset or a trimpot.

The percent on-time has a range of approximately 0 to 100 percent. The IT controllers operate at a constant frequency and the percent on-time is controlled by the pulse width of the voltage / current applied to the motor circuits.

Section 2.1.1.b Creep Speed

With the accelerator at maximum ohms or volts (approximately 3.7 to 3.5 VDC), the creep speed can be adjusted by Function 2 of the Handset. At creep speed, the ON time can decrease to approximately 5%, with the OFF time at approximately 95%. At full transistor operation, this condition will be reversed (short OFF time, long ON time). This variation of ON and OFF time of the oscillator varies the voltage applied to the motor, thereby varying the speed of the motor for a given load.

Section 2.1.1.c Control Acceleration

This feature allows for adjustment of the rate of time it takes for the control to accelerate to 100% applied battery voltage to the motor on hard acceleration. Armature C/A is adjusted by Function 3 from 0.1 to 22 seconds.

Section 2.1.2 Current Limit

This circuit monitors motor current by utilizing sensors in series with the armature and field windings. The information detected by the sensor is fed back to the card so that current may be limited to a pre-set value. If heavy load currents are detected, this circuit overrides the oscillator and limits the average current to a value set by Function 4 and Function 8 of the Handset. The C/L setting is based on the maximum thermal rating of the control. Because of the flyback current through 3REC, the motor current is usually greater than battery current, except at 100% ON time.

Section 2.1.3 Braking

Section 2.1.3.a Plug Braking

Section 2.1.3.b Regenerative Braking to Zero Speed

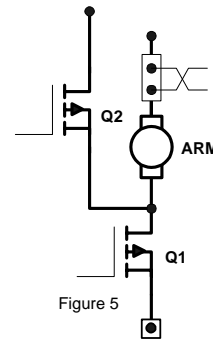

Slow down is accomplished when reversing direction by providing a small amount of retarding torque for deceleration. If the vehicle is moving, and the directional lever is moved from one direction to the other, the regen signal is initiated. Once the regen signal has been initiated, the field current is increased (armature circuit shown in Figure 5). Armature current is

regulated to the regen current limit as set by Function 9. As the vehicle slows down, the field current continues to increase, and transistor Q2 begins to chop. The field current will increase until it reaches a preset value set by Function 10, and transistor Q2 on-time will increase until it reaches 100% on-time. Once both of the above conditions have been met, and regen current limit can no longer be maintained, the braking function is canceled. The fields will then reverse, and the control reverts back to motoring. Part of the energy produced by the motor during regen is returned to the battery, and part is dumped in the motor as heat.

Section 2.1.3.c Pedal Position Plug Braking

This feature allows control of the plugging distance based on pedal position when there has been a "directional switch" change. Pedal position will reduce the regenerative current to the "value set by this function" as the accelerator is returned to the creep speed position. Maximum regen current is obtained with the accelerator in the top speed position.

Section 2.1.3.d Auto Braking

This feature is enabled by initiating a "neutral position" using either the directional switch or the accelerator switch. Once activated, Auto Braking operates similar to Pedal Position Plug Braking and is adjusted by using Function 21 of the Handset.

Section 2.1.4 Auxiliary Speed Control

Section 2.1.4.a Field Weakening

This function allows the adjustment of the field weakening level in order to set the top speed of the motor. The function is enabled when the armature current is less than the value set by Function 24 and the accelerator input voltage is less than 1 volt. It is important to note that this function is used to optimize motor and control performance, and this setting will be determined by GE and OEM engineers at the time of

vehicle development. This setting must not be changed by field personnel, without the permission of the OEM.

Section 2.1.4.b Speed Limits

This feature provides a means to control speed by limiting motor volts utilizing three "adjustable speed limits. This motor volt limit regulates top speed of the transistor controller, but actual truck speed will vary at any set point depending on the loading of the vehicle. Each speed limit can be adjustable with the Handset using Functions 11, 12, and 13.

Section 2.1.4.c Proportional Operation for Dual Motor Vehicles

A key performance advantage of this control is the ability to achieve actual "proportioning" of motor speed. In a non-proportioning, or single control, system when the vehicle starts to turn, the outside drive wheel turns in a larger circle than the inside wheel. Depending on the geometry of the vehicle, at some degree of turn angle, the inside wheel must slow down to prevent scrubbing of the wheel. This is accomplished on single control system by disconnecting the inside motor and letting the wheel "free wheel" or "float" at whatever speed is dictated by the outside wheel that is still under power. The main disadvantage of this system is that no torque is available on that motor when the inside wheel is in the "free-wheel" mode, and performance in a turn is reduced. When the steer wheel nears to the 90° turn angle, the inside motor is re-connected in the opposite direction of the outside. At this point, torque is returned to the inside wheel and the speed is the same on both motors.

With two controls, the speed of each motor can be regulated independently. The driver controls the speed of the outside wheel with the accelerator input signal. The inside wheel speed is controlled by the turn angle of the steer wheel. A potentiometer is attached to the steer wheel in order to communicate the steer angle to the controllers. During vehicle manufacture, software selection identifies each control for its application as a right or left control. The controls are physically identical, and it is only software that separates a right from a left control or differentiates a control for a dual motor application from one intended for a single motor vehicle. As the steer reaches some pre-selected turn angle, approximately 20°, the speed of the inside wheel decrease proportionally to the speed of the outside wheel. This proportional decline will continue on a linear path until the steer angle reaches another pre-determine angle of, approximately 65°.

At this point, the inside wheel will stop, as the steer angle is increased toward the 90° point, the inside wheel will reverse direction and start to accelerate proportionally in

speed. As the steer angle reaches the 90° point, the inside wheel speed will be the same as that of the outside wheel. During this entire turn, except for several degrees when the motor was stopped to change direction, torque was always present on the inside wheel, providing a smoother ride throughout the turning radius of the vehicle.

Details for adjustment of the steer angle potentiometer can be found in Appendix A of this manual.

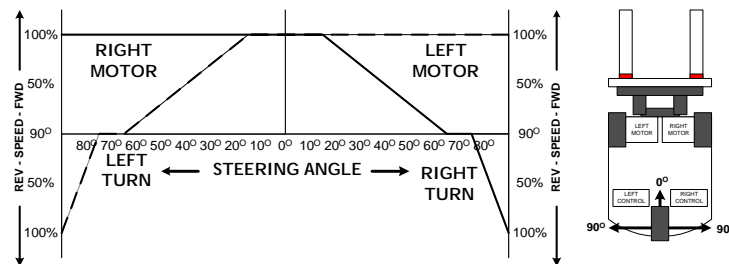

Section 2.1.5 Ramp Operation

Section 2.1.5a Ramp Start

This feature provides maximum control torque to restart a vehicle on an incline. The memory for this function is the directional switch. When stopping on an incline, the directional switch must be left in its original or neutral position to allow the control to initiate full power when restarted. The accelerator potentiometer input will modulate ramp start current.

Section 2.1.5b Anti-Rollback

This feature provides retarding torque to limit rollback speed in the non-travel direction when the ACC pedal is released when stopping on a grade, or when the brake pedal is released when starting on a grade. This feature forces the vehicle to roll very slowly down the grade when accelerator or brake is released. Because the vehicle can gain significant speed during roll-back, the torque needed to re-start on the ramp is lower than an unrestricted roll-back speed.

Section 2.1.6 Steer Pump Contactor Time Delay

This feature provides two options for SP time delay. Option 1 provides a 0.5 to 63 second time delayed drop out of the steer pump contactor when the Forward or Reverse directional switch is opened. This Option 1 is overridden by a 1.5 second time delayed drop out whenever the seat switch is opened. Option 2 provides a 0.5 to 63 second time delayed drop out of the SP contactor when the seat switch is opened.

Section 2.1.7 On-Board Coil Drivers & Internal Coil Suppression

Coil drivers for the LINE and SP contactors are on-board the control card. These contactors must have coils rated for the vehicle battery volts.

Section 2.2 System Protective Override

Section 2.2.1 Static Return to Off (SRO)

This inherent feature of the control is designed to require the driver to return the directional lever to the neutral position anytime he leaves the vehicle and returns. Additionally, if the seat switch or key switch is opened, the control shuts off and cannot be restarted until the directional lever is returned to neutral. A time delay of approximately 2 seconds is built into the seat switch input to allow momentary opening of the seat switch, if a bump is encountered.

Section 2.2.2 Accelerator Volts Hold Off

This feature checks the voltage level at the accelerator input whenever the key switch or seat switch is activated. If, at start up, the voltage is less than 3.0 volts, the control will not operate. This feature assures that the control is calling for low speed operation at start up.

Section 2.2.3 Pulse Monitor Trip (PMT)

The PMT design contains three features which shut down, or lock out, control operation if a fault conditions occurs that would cause a disruption of normal vehicle operation:

- Look ahead
- Look again
- Automatic look again and reset

The PMT circuit will not allow the control to start under the following conditions:

- The control monitors both armature and field FET's at start-up and during running.
- The control will not allow the line contactor to close at start-up, or will drop it out during running, if either the armature or field FET's are defective, so as to cause uncontrolled truck movement.

Section 2.2.4 Thermal Protector (TP)

This temperature sensitive device is internal to the power transistor (Q1) module. If the transistor's temperature begins to exceed the design limits, the thermal protector will lower the maximum current limit, and maintain the transistors within their temperature limits. Even at a reduced current limit, the vehicle will normally be able to

reach sufficient speed. As the control cools, the thermal protector will automatically reset, returning the control to full power.

Section 2.2.5 Low Voltage

Batteries under load, particularly if undersized or more than 80 percent discharged, will produce low voltages at the control terminals. The IT control is designed for use down to 50 percent of a nominal battery voltage of 36-84 volts, and 75 percent of a nominal battery voltage of 24 volts. Lower battery voltage may cause the control to operate improperly, however, the resulting PMT should open the Line contactor, in the event of a failure.

Section 2.3 Diagnostics

Section 2.3.1 Systems Diagnostics

The control detects the system's present operating status and can be displayed to either the Dash Display or the Handset. There are currently over 70 status codes that are available with IT systems using Traction and Pump controls and Truck Management Module (TMM). Along with the status code display from the TMM, the IT control is capable of reducing the current to the motor, alerting the operator of a critical fault condition.

Section 2.3.2 Status Codes

Section 2.3.2a Standard Status Codes

The IT traction control has over 30 Status Codes that assist the service technician and operator in trouble shooting the vehicle. If mis-operation of the vehicle occurs, a status code will be displayed on the Dash Display for vehicles so equipped, or be available by plugging the Handset into the "y" plug of the logic card.

With the status code number, follow the procedures outlined in DIAGNOSTIC STATUS CODES to determine the problem and a solution.

Note: The Status Code Instruction Sheets do not claim to cover all possible causes of a display of a "status code ". They do provide instructions for checking the most direct inputs that can cause status codes to appear.

Section 2.3.2.b Stored Status Codes

This feature records the last 16 "Stored Status Codes" that have caused a PMT controller shut down and/or disrupted normal vehicle operation. (PMT type faults are reset by cycling the key switch). These status codes, along with the corresponding BDI and hourmeter readings, can be accessed with the Handset, or by using the RS 232 communications port and dumping the information to a Personal Computer terminal.

Section 2.3.3 Hourmeter Readings

This feature will display the recorded hours of use of the traction and pump control to the Dash Display each time the key switch is turned off.

Section 2.3.3.a Maintenance Alert & Speed Limit

This feature is used to display Status Code 99 and/or activate a speed limit when the vehicle operating hours match the hours set into the maintenance alert register. This feature is set with the Handset using Functions 19 and 20. The operator is alerted that maintenance on the vehicle is required.

Section 2.3.4 Battery Discharge Indication (BDI)

The latest in microprocessor technology is used to provide accurate battery state of charge information and to supply passive and active warning signals to the vehicle operator. Features and functions:

- Displays 100 to 0 percent charge.
- Display blinks with 20% charge. Disables pump circuit with 10% charge. Auto ranging for 36/48 volt operation. Adjustable for use on 24 to 80 volts.

Section 2.3.4.a Internal Resistance Compensation

This feature is used when the Battery Discharge Indicator is present. Adjustment of this function will improve the accuracy of the BDI.

Section 2.3.5 Handset

This is a multi-functional tool used with the LX, ZX, SX and IT Series GE solid state controls. The Handset consists of a Light Emitting Diode (LED) display and a keyboard for data entry. Note, for ordering purposes, a separate Handset part is required for IT controls.

Features and functions:

- Monitor existing system status codes for both traction and pump controls. Monitor intermittent random status codes.
- Monitor battery state of charge, if available.
- Monitor hourmeter reading on traction and pump controls. Monitor or adjust the control functions.

Section 2.3.6 RS 232 Communication Port

This serial communication port can be used with Interactive Custom Dash Displays to allow changes to vehicle operating parameters by the operator. Or, it can be used by service personnel to dump control operating information and settings into a personal computer program.

Section 2.3.6.a Interactive Dash Display Modes

The Interactive Custom Dash Display allows the operator to select the best vehicle performance for changing factory (task) conditions. There are four (4) "operator interaction modes" that can be selected by depressing a push button on the dash display.

From the Dash Display, the operator may select any of four pre-set interactive modes consisting of (4) Controlled Acceleration levels, (4) Field Weakening levels and (4) Speed Limits.

These interactive modes are "pre-set" using the Handset (Functions 48-62) or a personal computer (Functions 97-112). This feature allows the operator to select the best vehicle performance for changing factory (task) conditions.

Section 2.3.7 Circuit Board Coil Driver Modules

Coil drivers are internal to the control card, and are the power devices that operate the Line and SP contactor coils. On command from the control card, these drivers initiate opening and closing the contactor coils. All driver modules are equipped with reverse battery protection, such that, if the battery is connected incorrectly, the contactors can not be closed electrically.

Section 2.3.8 Truck Management Module (TMM)

The Truck Management Module is a multifunction accessory card, or an integral function of the GE Pump controls when used with the IT Traction control. The Module provides the OEM the ability to initiate status codes or operator warning codes to be displayed on the Dash Display, whenever a normally open switch or sensor wire provides a signal to the Module.

The TMM Module can be used to display a separate status code indicating over-temperature of traction motors, hydraulic motors, or any other device or system that can activate a switch that closes.

The TMM Module can also be used as a Brush Wear Indicator (BWI). The Brush Wear Indicator is designed to detect a "worn out brush" and display a fault code on the Dash Display to warn maintenance personnel that the motor brushes need to be replaced before they wear to the point of causing destructive damage to the motor commutator surface.

Section 2.4 Hydraulic Pump Control

This hydraulic motor controller consists of the following features:

- Three speeds, adjustable from 0 to 100% motor volts. Fixed speeds actuated by switch closure to negative.
- Current limit and controlled acceleration adjustable.
- Battery Discharge Indicator interrupt compatible.

Operation of voltage regulator card: This card provides the basic functions required for controlling the pump control, optional contactors, and PMT functions. Battery positive is applied through a main control fuse to the key switch, energizing the control card power supply input to P1.

When a pump contactor is used, PMT operation is the same as outlined for the traction controllers.

The three speed (motor volts) reference points P12, P19, and P20 are selected by connecting these points independently to battery negative.

The first speed is obtained by closing Speed Limit I (P12) to control negative. SL1 is adjustable by Function 11 using the Handset to adjust motor voltage from 0 to 100%. The specified motor volts will be regulated, however, the magnitude of motor current will vary depending on the loading of the vehicle.

The second speed is obtained by closing SL2 (P19) to control negative. SL2 is adjusted using the Handset and Function 12 similar to SL1.

The third speed is obtained by closing SL3 (P20) to control negative. SL3 is adjusted using the Handset and Function 13 similar to SL1.

If more than one Speed Limit is activated, the selected speed with the highest motor volts will override the low motor volt speed. The current limit circuit is adjustable and operates the same as the traction current limit.

The controlled acceleration circuit is adjustable and operates the same as the traction circuit. Adjustment range is from 0.1 to 5.5 seconds.

The Battery Discharge Indicator (BDI) interrupt will disable the hydraulic controller if the connection at P10 loses the 12 volt signal from the traction control. BDI interrupt can be disabled by Function 17 using the Handset. Select card type with or without BDI function.

Section 3.0 ORDERING INFORMATION, ELEMENTARY AND OUTLINE DRAWINGS

Section 3.1 Ordering Information for Separately Excited Controls

Example:

Part Number: IC3645 SH 4 D 33 2 C3
Argument Number: 01 02 03 04 05 06 07

Argument 01: Basic Electric Vehicle Control Number

Argument 02: Control Type:

SP = Series Control (Pump)
 SH = Separately Excited Control (Plugging)
 SR = Separately Excited Control (Regen to Zero)

Argument 03: Operating Voltage:

| | |
|-----------------|-----------------|
| 1 = 120 volts | 4 = 48 volts |
| 2 = 24 volts | 5 = 36/48 volts |
| 3 = 36 volts | 6 = 24/36 volts |
| 7 = 72/80 volts | |

Argument 04: Package Size:

| |
|--------------------|
| D = 6.86" X 6.67" |
| R = 6.86" X 8.15" |
| T = 9.63" X 7.05" |
| U = 8.66" X 8.13" |
| W = 8.66" X 10.83" |

Argument 05: Armature Current
(2 characters)

22 = 220 Amps
 33 = 330 Amps
 40 = 400 Amps
 etc.

Argument 06: Field Current
(1 character)

2 = 20 Amps
 3 = 30 Amps
 4 = 40 Amps
 etc.

Argument 07: Customer / Revision

A1 = Customer A / Revision 1
 B1 = Customer B / Revision 1
 etc.

Section 3.2 Outline: IT400 Package Size

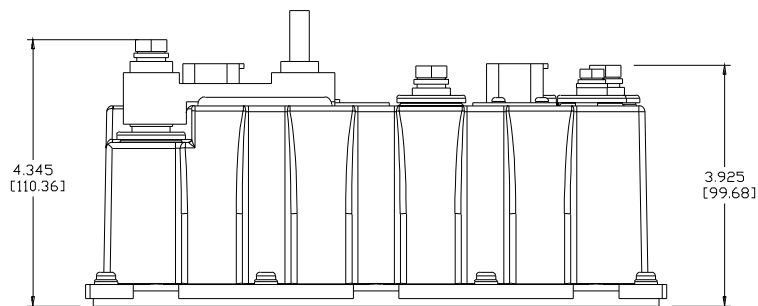
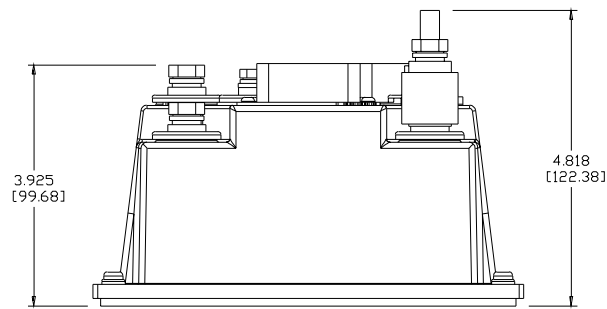
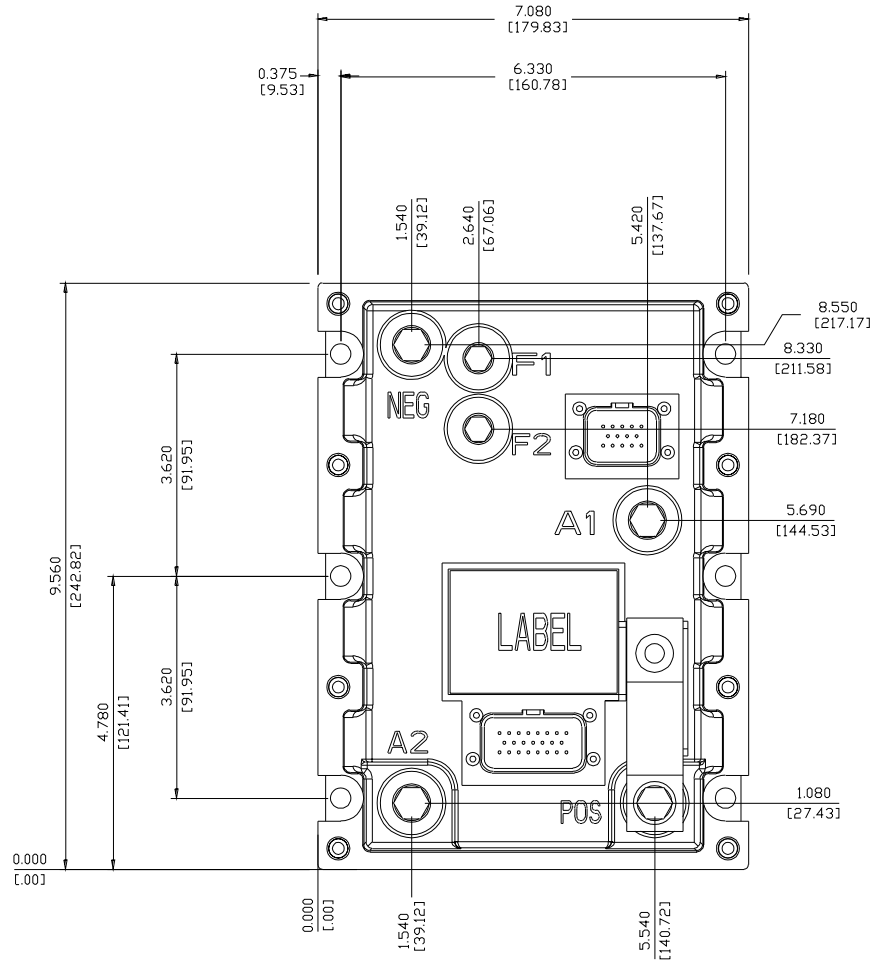

Section 3.3 Outline: IP400 Package Size

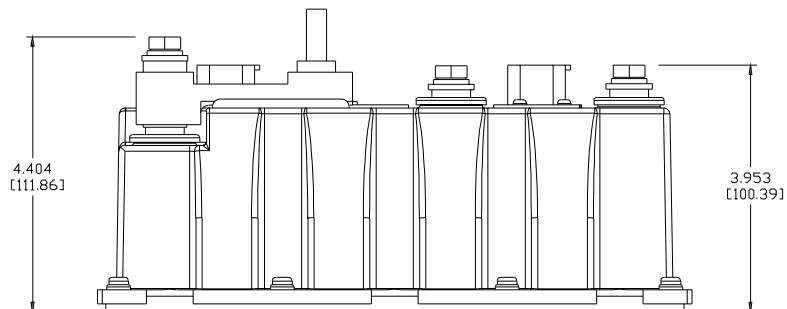
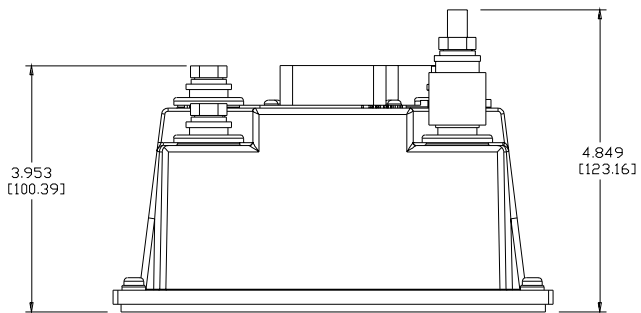
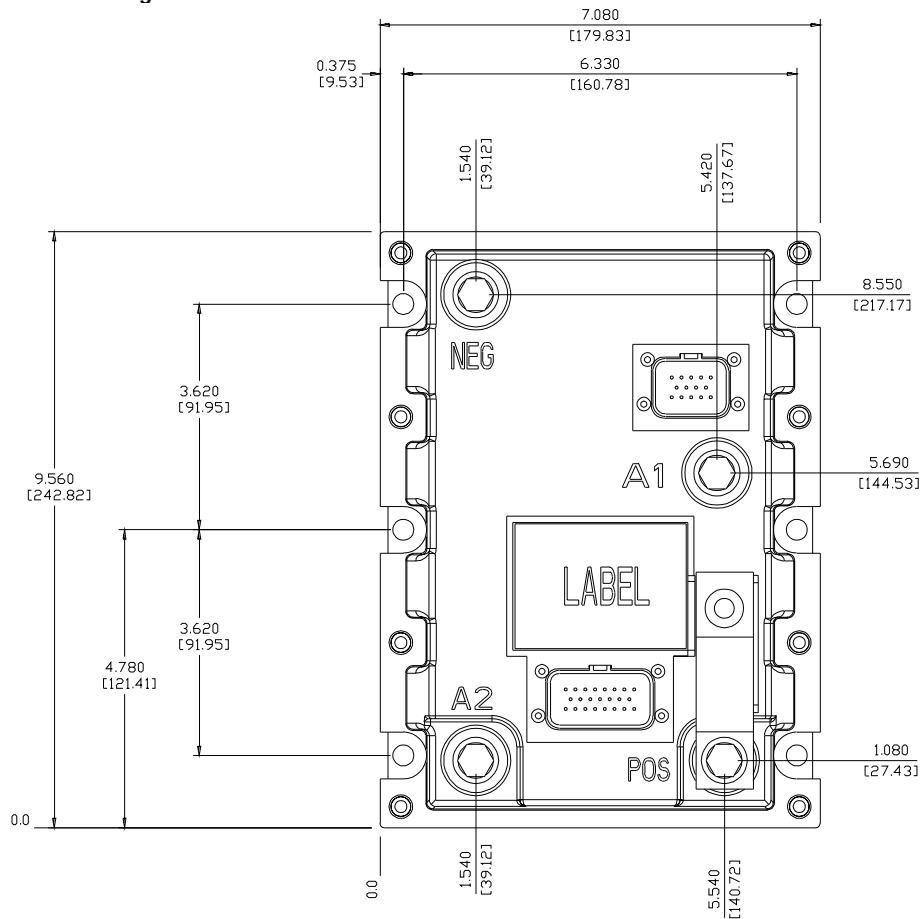

Section 3.4 Traction Elementary

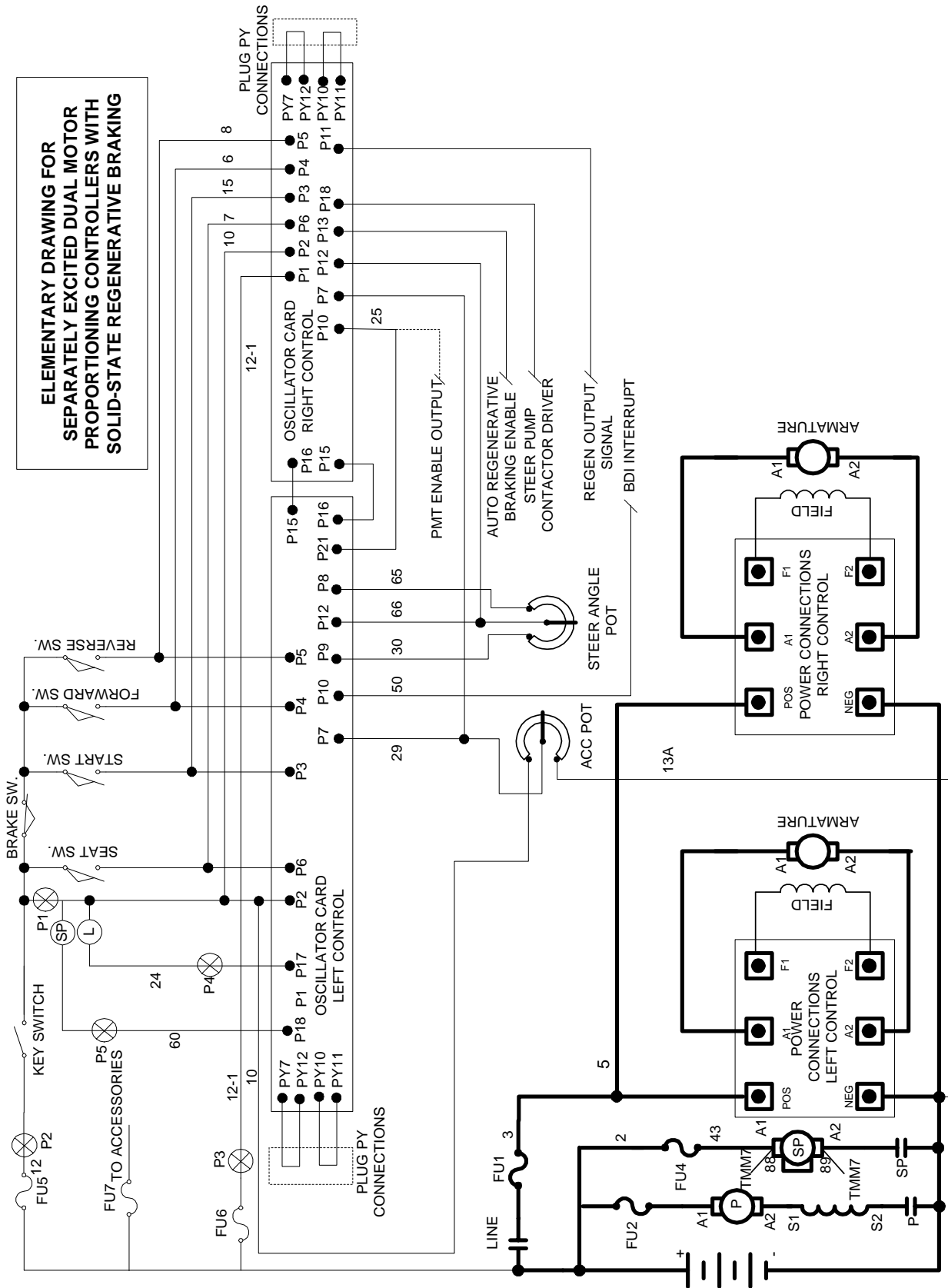

Section 3.5 Pump Elementary

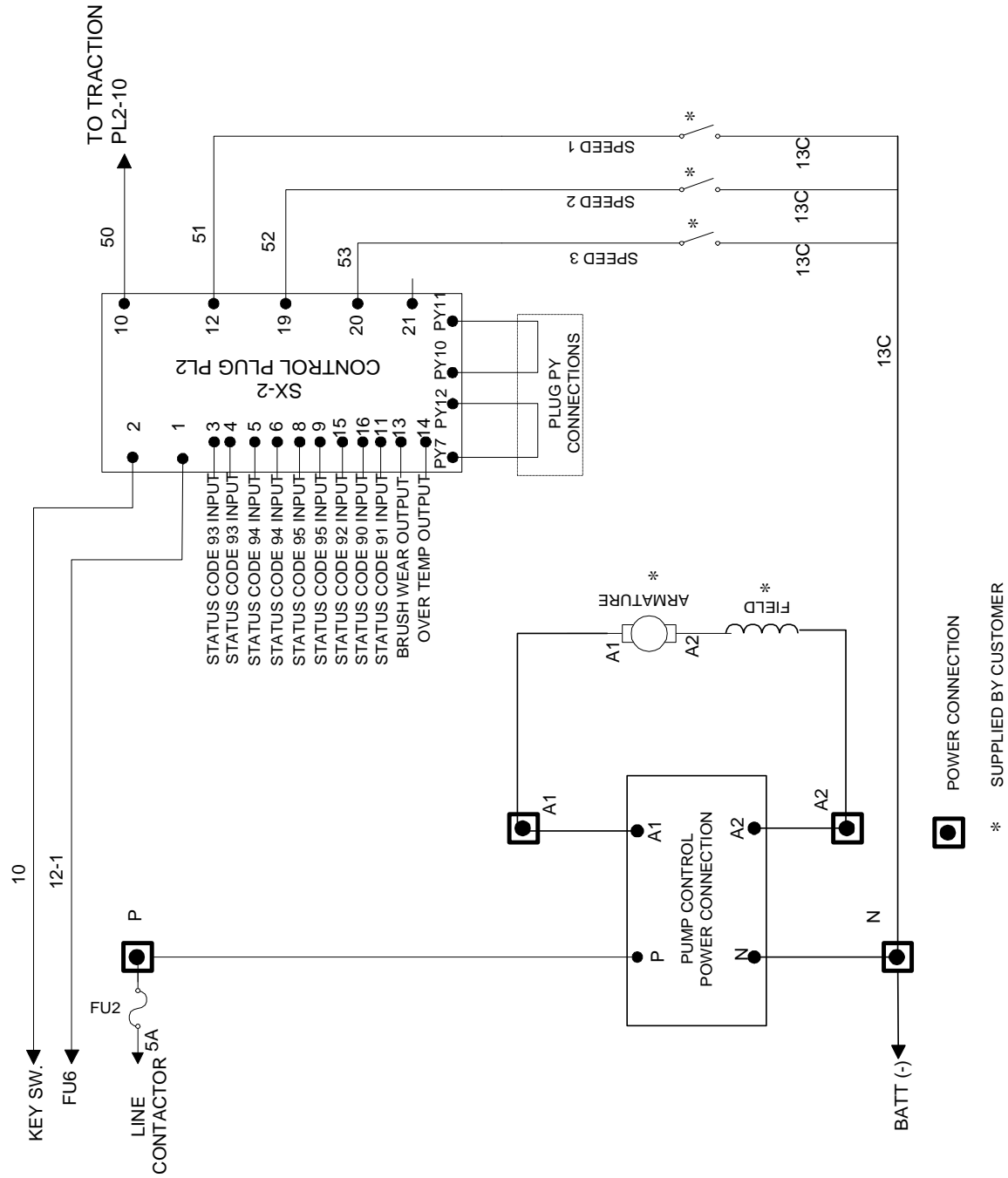

Section 3.6. Traction and Pump Control Input and Output List
CONNECTIONS TO MAIN PLUG (23 PIN) AND "Y" PLUG (14 PIN)

| PIN | TRACTION INPUT/OUTPUT DESCRIPTION | PUMP INPUT/OUTPUT DESCRIPTION |
|-----|---|--|
| 1 | BATTERY VOLTS FROM BATTERY | BATTERY VOLTS FROM BATTERY |
| 2 | BATTERY VOLTS FROM KEY | BATTERY VOLTS FROM KEY |
| 3 | BATTERY VOLTS FROM START SWITCH | STATUS CODE 93 INPUT |
| 4 | BATTERY VOLTS FROM FORWARD SWITCH | STATUS CODE 93 INPUT |
| 5 | BATTERY VOLTS FROM REVERSE SWITCH | STATUS CODE 94 INPUT |
| 6 | BATTERY VOLTS FROM SEAT SWITCH | STATUS CODE 94 INPUT |
| 7 | ACCELERATOR INPUT VOLTAGE SIGNAL | POTENTIOMETER INPUT VOLTAGE SIGNAL |
| 8 | STEER ANGLE POT NEGATIVE | STATUS CODE 95 INPUT |
| 9 | STEER ANGLE POT +5 VOLTS SUPPLY | STATUS CODE 95 INPUT |
| 10 | BDI INTERRUPT | PUMP ENABLE SIGNAL 12VDC |
| 11 | PLUG/RGN OUTPUT SIGNAL +12V 1.0V=REGEN | STATUS CODE 91 INPUT |
| 12 | STEER ANGLE INPUT VOLTAGE SIGNAL | SPEED LIMIT #1 INPUT |
| 13 | RGN BRAKE POTENTIOMETER INPUT | TMM1 BRUSHWEAR INDICATER OUTPUT |
| 14 | TMM BRUSHWEAR | TMM1 OVER TEMPERATURE OUTPUT |
| 15 | I _{MOTOR} OUT | STATUS CODE 92 INPUT |
| 16 | MOTOR CURRENT COMPENSATION | STATUS CODE 90 INPUT |
| 17 | LINE CONTACTOR DRIVER AND SUPPRESSION | LINE CONTACTOR DRIVER |
| 18 | STEER PUMP CTR DRIVER AND SUPPRESSION | 1A CONTACTOR DRIVER |
| 19 | DASH DISPLAY + 5 VOLT SUPPLY | SPEED LIMIT #2 INPUT |
| 20 | TMM OVERTEMP | SPEED LIMIT #3 INPUT |
| 21 | NOT USED | NOT USED |
| 22 | SERIAL RECEIVE / DASH DISPLAY | SERIAL RECEIVE |
| 23 | SERIAL TRANSMIT / DASH DISPLAY | SERIAL TRANSMIT |
| PIN | MOTOR PROPORTIONING "Y" PLUG INPUT/OUTPUT DESCRIPTION | PUMP "Y" PLUG INPUT/OUTPUT DESCRIPTION |
| 1 | CLOCK (OUT) | CLOCK (OUT) |
| 2 | DATA (OUT) | DATA (OUT) |
| 3 | ENABLE (OUT) | ENABLE (OUT) |
| 4 | NEGATIVE | NEGATIVE |
| 5 | +5V SUPPLY | +5V SUPPLY |
| 6 | CONT/STORE (IN) (HANDSET) | CONT/STORE (IN) (HANDSET) |
| 7 | EXTERNAL JUMPER TO PY12 | EXTERNAL JUMPER TO PY12 |
| 8 | VALUE | VALUE |
| 9 | FUNCTION | FUNCTION |
| 10 | EXTERNAL JUMPER TO PY11 | EXTERNAL JUMPER TO PY11 |
| 11 | SERIAL RECEIVE / CONNECT TO P22 | SERIAL RECEIVE / CONNECT TO P22 |
| 12 | SERIAL TRANSMIT / CONNECT TO P23 | SERIAL TRANSMIT / CONNECT TO P23 |
| 13 | NOT USED | NOT USED |
| 14 | NOT USED | NOT USED |

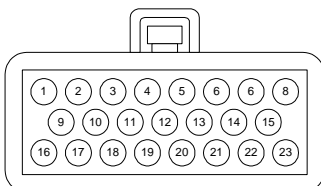

WIRE END VIEW – MAIN PLUG

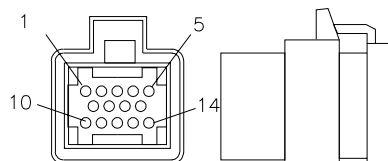

WIRE END VIEW "Y" PLUG

Section 4.0 TROUBLESHOOTING AND DIAGNOSTIC STATUS CODES

Section 4.1 General Maintenance Instructions

The transistor control, like all electrical apparatus, does have some thermal losses. The semiconductor junctions have finite *temperature* limits, above which these devices may be damaged. For these reasons, normal maintenance should guard against any action which will expose the components to excessive heat and/or those conditions which will reduce the heat dissipating ability of the control, such as restricting air flow.

The following Do's and Don't's should be observed:

Any controls that will be applied in ambient temperatures over 100° F (40° C) should be brought to the attention of the vehicle manufacturer.

All external components having inductive coils must be filtered. Refer to vehicle manufacturer for specifications.

The wiring should not be directly steam cleaned. In dusty areas, blow low-pressure air over the control to remove dust. In oily or greasy areas, a mild solution of detergent or denatured alcohol can be used to wash the control, and then low-pressure air should be used to completely dry the control.

For the control to be most effective, it must be mounted against the frame of the vehicle. The metal vehicle frame, acting as an additional heat sink, will give improved vehicle performance by keeping the control package cooler. *Apply a thin layer of heat-transfer grease (such as Dow Corning 340) between the control heat sink and the vehicle frame.*

Control wire plugs and other exposed transistor control parts should be kept free of dirt and paint that might change the effective resistance between points.

CAUTION: The vehicle should not be plugged when the vehicle is jacked up and the drive wheels are in a free wheeling position. The higher motor speeds can create excessive voltages that can be harmful to the control.

Do not hipot (or megger) the control. Refer to control manufacturer before hipotting.

Use a lead-acid battery with the voltage and ampere hour rating specified for the vehicle. Follow normal battery maintenance procedures, recharging before 80 percent discharged with periodic equalizing charges.

Visual inspection of GE contactors contained in the traction and pump systems is recommended to occur during every

1000 hours of vehicle operation. Inspection is recommended to verify that the contactors are not binding and that the tips are intact and free of contaminants.

GE does not recommend that any type of welding be performed on the vehicle after the installation of the control(s) in the vehicle. GE will not honor control failures during the warranty period when such failures are attributed to welding while the control is installed in the vehicle.

Section 4.2 Cable Routing and Separation

Electrical noise from cabling of various voltage levels can interfere with a microprocessor-based control system. To reduce this interference, GE recommends specific cable separation and routing practices, consistent with industry standards.

Section 4.2.1 Application Responsibility

The customer and customer's representative are responsible for the mechanical and environmental locations of cables. They are also responsible for applying the level rules and cabling practices defined in this section. To help ensure a lower cost, noise-free installation, GE recommends early planning of cable routing that complies with these level separation rules.

On new installations, sufficient space should be allowed to efficiently arrange mechanical and electrical equipment.

On vehicle retrofits, level rules should be considered during the planning stages to help ensure correct application and a more trouble-free installation.

Section 4.2.2. Signal/Powerlevel Definitions

The signal/power carrying cables are categorized into four defining levels: low, high, medium power, and high power. Within those levels, signals can be further divided into classes.

Sections 4.2.2.a through 4.2.2.d define these levels and classes, with specific examples of each. Section 4.2.3 contains recommendations for separating the levels.

4.2.2.a Low-Level Signals (Level L)

Low-level signals are designated as *level L*. These consist of:

- Analog signals 0 through ± 15 V
- Digital signals whose logic levels are less than 15 V DC
- 4 – 20 mA current loops
- DC busses less than 15 V and 250 mA

The following are specific examples of level L signals used in drive equipment cabling:

- Control common tie
- DC buses feeding sensitive analog or digital hardware
- All wiring connected to components associated with sensitive analog hardware with less than 5V signals (for example, potentiometers and tachometers)
- Digital tachometers and resolvers
- Dash display cabling
- RS-232 cabling

Note: Signal inputs to analog and digital blocks should be run as shielded twisted-pair (for example, inputs from tachometers, potentiometers, and dash displays).

4.2.2.b High-Level Signals (Level H)

High-level signals are designated as *level H*. These signals consist of:

- Analog and digital signals greater than 15 V DC and less than 250 mA

For example, switch inputs connected to battery volts are examples of level H signals used in drive equipment cabling.

4.2.2.c Medium-Power Signals (Level MP)

Medium power signals are designated as *level MP*. These signals consist of:

- DC switching signals greater than 15 V
- Signals with currents greater than 250 mA and less than 10A

The following are specific examples of level MP signals used in drive equipment cabling:

- DC busses less than 10 A
- Contactor coils less than 10 A
- Machine fields less than 10 A

4.2.2.d. High Power Signals (Level HP)

Power wiring is designated as *level HP*. This consists of DC buses and motor wiring with currents greater than 10 A. The following are specific examples of level HP signals used in drive equipment cabling:

- Motor armature loops
- DC outputs 10 A and above
- Motor field loops 10 A and above

4.2.3. Cable Spacing Guidelines

Recommended spacing (or clearance) between cables (or wires) is dependent on the level of the wiring inside them. For correct level separation when installing cable, the

customer must apply the **general guidelines** (section 4.2.3.a), outlined below.

4.2.3.a General Cable Spacing

The following general practices should be used for *all levels* of cabling:

- All cables and wires of like signal levels and power levels must be grouped together.
- In general, different levels must run in separate wire bundles, as defined in the different classes, identified above. Intermixing cannot be allowed, unless noted by exception.
- Interconnecting wire runs should carry a level designation.
- If wires are the same level and same type signal, group those wires from one location to any other location together in multiconductor cables or bind them together with twine or zip-ties.
- When unlike signals must cross, cross them in 90° angles at a maximum spacing. Where it is not possible to maintain spacing, place a grounded steel barrier between unlike levels at the crossover point.

4.2.4 Cabling for Vehicle Retrofits

Reducing electrical noise on vehicle retrofits requires careful planning. Lower and higher levels should never encircle each other or run parallel for long distances. It is practical to use existing wire runs or trays as long as the level spacing (see section 4.2.2) can be maintained for the full length of the run.

Existing cables are generally of high voltage potential and noise producing. Therefore, route levels L and H in a path separate from existing cables, whenever possible.

For level L wiring, use barriers in existing wire runs to minimize noise potential.

Do not loop level L signal wires around level H, level MP, or HP wires.

4.2.5 RF Interference

To prevent radio frequency (RF) interference, care should be taken in routing power cables in the vicinity of radio-controlled devices.

Section 4.2.6 Suppression

Unless specifically noted otherwise, suppression (for example, a snubber) is required on all inductive devices controlled by an output. This suppression minimizes noise and prevents damage caused by electrical surges.

Section 4.3 Recommended Lubrication of Pins and Sockets Prior to Installation

Beginning in January of 1999, GE will implement the addition of a lubricant to all connections using pins and sockets on EV100/EV200 and Gen II products. Any connection made by GE to the A, B, X, Y, or Z plugs will have the lubricant NYE 760G added to prevent fretting of these connections during vehicle operation.

Fretting occurs during microscopic movement at the contact points of the connection. This movement exposes the base metal of the connector pin which, when oxygen is present, allows oxidation to occur. Sufficient build up of the oxidation can cause intermittent contact and intermittent vehicle operation. This can occur at any similar type of connection, whether at the control or in any associated vehicle wiring, and the resultant intermittent contact can provide the same fault indication as actual component failure.

The addition of the NYE 760G lubricant will prevent the oxidation process by eliminating the access of oxygen to the contact point. GE recommends the addition of this lubricant to the 12 pin and 23 pin plugs of all new Gen II controls at the time of their installation into a vehicle

When servicing existing vehicles exhibiting symptoms of intermittent mis-operation or shutdown by the GE control, GE recommends the addition of this lubricant to all 12 and 23 pin plugs, after proper cleaning of the connectors, as a preventative measure to insure fretting is not an issue before GE control replacement. Also, for long term reliable control operation, the plug terminals must be maintained per these instructions with the recommended contact cleaner and lubricant which provides a high degree of environmental and fretting protection.

New and re-manufactured control plugs are cleaned and lubricated prior to shipment from the factory. However, in applications where severe vibration or high temperature cycling and excessive humidity (such as freezers) are present, it is recommended that the plug terminals be cleaned and lubricated every year, per this instructions. In normal applications, plug maintenance should be performed every two years, unless intermittent problems arise with the plugs, requiring more immediate attention.

Warning: Do not use any other cleaners or lubricants other than the ones specified.

WARNING: Before conducting maintenance on the vehicle, jack up the drive wheels, disconnect the battery and discharge the capacitors. Consult the Operation and Service Manual for your particular vehicle for details on discharging the capacitors; this procedure differs between SCR and Transistor controls.

1. **Disconnect** plug from controller or mating plug.

2. **Locate** the plug that contains the socket (female) terminals. *Maintenance needs only to be performed on the plug containing the socket (female) type terminals. Reconnecting the plugs will lubricate the pin (male) terminals.*
3. **Clean** each terminal using Chemtronics contact cleaner "Pow-R-WasH CZ " as shown in Figure 1.

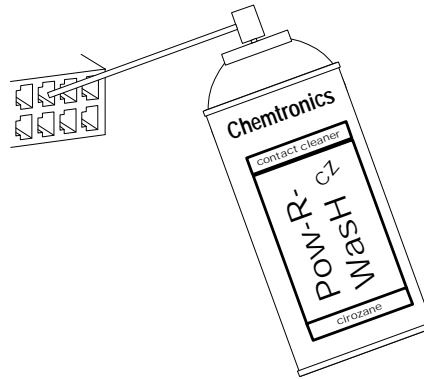

Figure 1

4. **Lubricate** each terminal using Nye 760G lubricant as shown in figure 2. Apply enough lubricant to each terminal opening to completely fill each opening to a depth of .125" maximum.

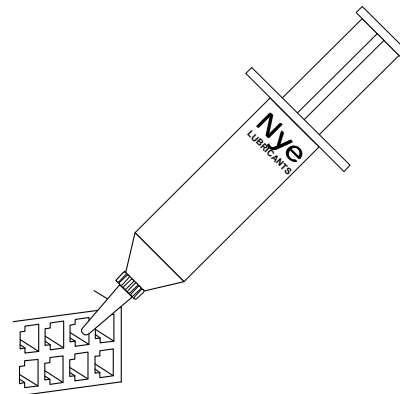

Figure 2

5. **Reconnect** plugs.

Reference

| | |
|-----------------|--|
| Cleaner | Chemtronics Pow-R-WasH CZ Contact Cleaner |
| Lubricant | Nye Lubricants NYOGEL 760G |
| GE Plug Lub Kit | Contains both above products: 328A1777G1 |

Section 4.4 Controller Mounting Guidelines

In the design of the GE family of motor controls, performance assumptions were made based on heat transfer between the control and the ambient environment. The vehicle mounting surface acts as a heat sink, which increases the effective surface area for heat dissipation. If this assumed heat transfer is not achieved during control installation and operation, GE controllers will fall short of their anticipated performance. It should be noted that the condition of the mounting surface, and the quality of the resulting interface between the control and the vehicle, can significantly hinder heat transfer from the control. The presence of contaminants, or of air voids created by surface inconsistencies in either the vehicle or the control, degrade the control's capacity for heat transfer. The control's performance is de-rated proportionally as its own thermal sensors reduce its operation to protect it from damage due to excessive heating.

Contained within the software of the GE controls are several diagnostic status codes related to controller thermal performance. Failure to follow these mounting recommendations increases the likelihood of encountering these status codes, through no fault of the control itself, thus voiding controller warranty for units returned solely due to the presence of these status codes.

Careful surface preparation, including adequate application of thermal compound, as detailed in the following paragraphs, must be completed during the installation of GE controls. There are many techniques for applying thermal compound, and we have outlined one approach below that has shown to apply a consistent thickness of material.

Section 4.4.1 Necessary Tools

GE recommends the use of the following components, or equivalent substitutions, during the control installation process:

- a) Thermal compound, (Dow Corning #340), maintained per the manufacturer's recommendations and free of contaminants
- b) 3/32" notched trowel, such as a Krusin adhesive spreader, model 00031
- c) Calibrated torque wrench (0 – 15 ft-lbs)

Section 4.4.2 The GE Control Mounting Surface

During the manufacture of the GE control, the surface flatness is maintained at 0.005" per linear inch (not to exceed 0.025" per 10.0 inches). The surface finish of the GE control has an R_a (average roughness) of 64 (microinches), or better. This finish is consistent with cold rolled or extruded aluminum.

Care should always be taken in the handling and storage of controllers. The base of the control should be free from nicks, bumps, protrusions or any other foreign object that

would prevent the control from sitting flush with the vehicle mounting surface. Examine the base of the control to verify that it is in good condition and free from damage or contamination.

Section 4.4.3 Vehicle Mounting Surface

The quality of the vehicle mounting surface is critical for the optimum heat transfer between the control and the ambient environment. Conduction through the base of the control is the control's only means of heat rejection. While GE controls are highly efficient, a few percent of the electrical energy will be converted into heat. As previously mentioned, if this energy is not dissipated through the base of the control, a thermal protector will reduce the performance of the control until the temperature stabilizes.

For optimal heat transfer from control to vehicle, the flatness of the vehicle mounting surface should be equivalent to the flatness of the control surface (0.005" per linear inch). Use a straight edge or dial indicator to verify the mounting surface.

The biggest hindrance to heat transfer is the presence of rust, scale, weld splatter or paint on the vehicle mounting surface. If any of these items are noted, prepare the surface per the following guidelines:

- a) Clean the mounting surface with a rotary wire brush until the metal surface is exposed.
- b) Using 80-100 grit emery paper, sand the surface until the metal shines.
- c) Flush the surface clean with an appropriate liquid de-greaser or parts cleaner.

Section 4.4.4 Application of Thermal Compound

Due to the minute differences in the control mounting surface and the vehicle mounting surface, small pockets of air will be created. These air pockets will add to the overall thermal resistance of the interface.

To avoid these air pockets and improve thermal conductivity, thermal compound must be applied between the GE control base plate and the vehicle mounting surface. The function of this compound is to conform to surface discrepancies, filling gaps and optimizing the metal-to-metal contact of the control and the vehicle.

- a) Prepare the two mounting surfaces (control and vehicle) as indicated above.
- b) Using a triangular notched trowel of 3/32" (.09" +/- .01), apply the grease to the vehicle mounting surface.
- c) Use straight, non-crossing strokes of the trowel to apply the compound.
- d) Make multiple vertical passes until a uniform consistency is achieved.



Krusin adhesive spreader model 00031



Vehicle surface after proper grease application

Section 4.4.5 Mounting the GE Control

- Place the control unit with desired orientation on mounting plate with mounting holes aligned.
- Move the control slightly in all directions to eliminate voids and enhance the distribution of the thermal compound.
- Insert the all of the mounting hardware (4, 6 or 8 bolts, M6 or M8, necessary for the mounting of the respective family of controls).
- Tighten these bolts (as per sequence shown in diagrams below) to half of the nominal torque value (**7.5lb-ft**).
- Lastly, tighten the bolts to the nominal torque value (**15 lb-ft**), following the same sequence.



Calibrated torque wrench for hardware installation

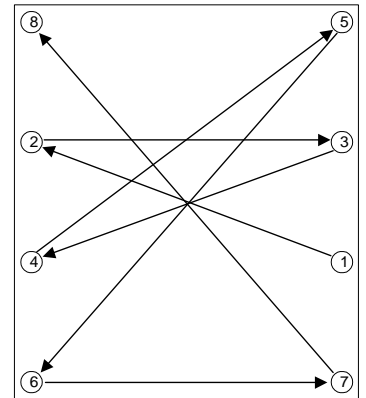
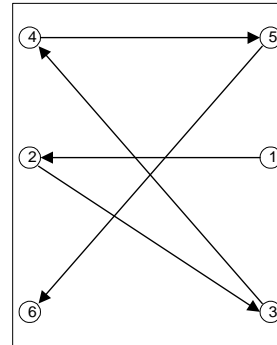
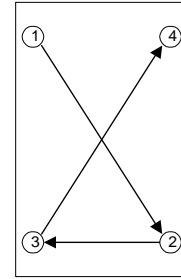
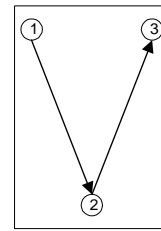

Proper sequence for use in tightening hardware during control mounting

Section 4.4.6 Maintenance

If it is necessary to remove the control for service, careful consideration must be given to removing the old thermal compound from the control and mounting surface, prior to replacement of the unit. **Never** re-use thermal compound. Use a putty knife or similar straight edge to carefully remove all thermal compound residue without damaging either mounting surface. Flush the surfaces with a liquid de-greaser or parts cleaner and allow them to dry, before re-applying the thermal compound and mounting the control. Take care not to contaminate the surfaces with hydraulic fluid or battery acid.

Section 4.5 General Troubleshooting Instructions

Trouble-shooting the SX family of controls should be quick and easy when following the instructions outlined in the following status code instruction sheets.

If mis-operation of the vehicle occurs, a status code will be displayed on the Dash Display (for vehicles equipped with a Dash Display) or made available by plugging a Handset into the plug "Y" location, and then reading the status code.

Note: Status code numbers from 00 to 99 are traction control status codes. Status codes with the prefix 1 (101 to 199) are pump control status codes.

With the status code number, follow the procedures outlined in the status code instruction sheets to determine the problem.

Important Note: Due to the interaction of the logic card with all vehicle functions, almost any status code or control fault could be caused by the logic card. After all other status code procedures have been followed and no problem is found, the controller should then be replaced as the last option to correct the problem.

The same device designations have been maintained on different controls but the wire numbers may vary. Refer to the elementary and wiring diagrams for your specific control. The wire numbers shown on the elementary diagram will have identical numbers on the corresponding wiring diagrams for a specific vehicle, but these numbers may be different from the numbers referenced in this publication.

WARNING: Before trouble-shooting, jack up the drive wheels, disconnect the battery and discharge the capacitors. Reconnect the battery as needed for specific checks. Capacitors should be discharged by connecting a 200 ohm 2 watt resistor between the positive and negative terminals on the control panel.

Check resistance on R x 1000 scale from frame to power and control terminals. A resistance of less than 20,000 ohms can cause misleading symptoms. Resistance less than 1000 ohms should be corrected first.

Before proceeding, visually check for loose wiring, mis-aligned linkage to the accelerator switch, signs of overheating of components, etc.

Tools and test equipment required are: clip leads, volt-ohm meter (20,000 ohms per volt) and basic hand tools.

Section 4.6 Traction Control Codes

| TRACTION STATUS CODE | DESCRIPTION OF STATUS | CAUSE OF STATUS INDICATION |
|--|--|---|
| NONE | Segments do not illuminate on the Dash Display and/or the Handset. | No input voltage to the control card or the display unit. |
| MEMORY RECALL NO | CORRECTIVE ACTIONS | <u>TROUBLE-SHOOTING DIAGRAM</u> |
| Circuits valid for Traction Controller | <p><u>SYMPTOM</u> Display screen on Dash Display and/or Handset is blank.</p> <p><u>POSSIBLE CAUSE</u> Positive or negative control voltage is not present.</p> <ul style="list-style-type: none"> • Insure that the key switch is closed and voltage is present between P1 & battery negative (Power Terminal "NEG"). Also check for voltage between P2 and control negative. <p>Open circuit between control card AND the Dash Display or Handset.</p> <ul style="list-style-type: none"> • Check for an open circuit or loose connection going from the control and the Dash Display or Handset. <p>Defective Dash Display or Handset.</p> <ul style="list-style-type: none"> • Replace Dash Display or Handset. | |

| TRACTION STATUS CODE | DESCRIPTION OF STATUS | CAUSE OF STATUS INDICATION |
|--|---|--|
| -01 | No seat switch or deadman switch input (no voltage to P6). | This status code will be displayed when P6 is less than 50% battery volts. |
| MEMORY RECALL NO | CORRECTIVE ACTIONS | <u>TROUBLE-SHOOTING DIAGRAM</u> |
| Circuits valid for Traction Controller | <p><u>SYMPTOM</u> Control will not operate.</p> <p><u>POSSIBLE CAUSE</u> Mis-adjusted or defective seat or deadman switch.</p> <ul style="list-style-type: none"> • Check to see that the seat switch closes properly. <p>Open circuit between battery positive and P6.</p> <ul style="list-style-type: none"> • Check for loose connections or broken wires: <ul style="list-style-type: none"> - Between the seat switch and P6 - Between the key switch and the battery positive side of the seat switch. - Between the seat switch and P2. • On vehicles without a seat/deadman switch, check for a loose connection or broken wire from P2 and/or P6. | |

| TRACTION STATUS CODE | DESCRIPTION OF STATUS | CAUSE OF STATUS INDICATION |
|--|--|---|
| -02 | Forward directional switch is closed on initial power up. | This status code will be displayed when P4 is greater than 60% of battery voltage at initial key switch on. |
| MEMORY RECALL NO | CORRECTIVE ACTIONS | <u>TROUBLE-SHOOTING DIAGRAM</u> |
| Circuits valid for Traction Controller | <p><u>SYMPTOM</u> Control will not operate because of Static Return to Off (SRO) lock out.</p> <p><u>POSSIBLE CAUSE</u> Forward directional switch is closed on initial start up (i.e. closure of battery, key switch or seat switch).</p> <ul style="list-style-type: none"> Return directional switch lever to neutral and then return lever to forward position. <p>Forward directional switch is welded closed or mis-adjusted to be held closed.</p> <ul style="list-style-type: none"> Replace or adjust directional switch to insure that it opens when the directional switch is returned to neutral. <p>Short circuit between P3 and P4.</p> <ul style="list-style-type: none"> Disconnect the wire from P4 and check for a short circuit between P3 and the wire that was connected to P4. <p>Defective control.</p> <ul style="list-style-type: none"> Replace the controller unit. | |

| TRACTION STATUS CODE | DESCRIPTION OF STATUS | CAUSE OF STATUS INDICATION |
|--|--|---|
| -03 | Reverse directional switch is closed on initial power up. | This status code will be displayed when P5 is greater than 60% of battery voltage at initial key switch on. |
| MEMORY RECALL NO | CORRECTIVE ACTIONS | <u>TROUBLE-SHOOTING DIAGRAM</u> |
| Circuits valid for Traction Controller | <p><u>SYMPTOM</u> Control will not operate because of Static Return to Off (SRO) lock out.</p> <p><u>POSSIBLE CAUSE</u> Reverse directional switch is closed on initial start up (i.e. closure of battery, key switch or seat/deadman switch).</p> <ul style="list-style-type: none"> Return directional switch lever to neutral and then return lever to reverse position. <p>Reverse directional switch is welded closed or mis-adjusted to be held closed.</p> <ul style="list-style-type: none"> Replace or adjust directional switch to insure that it opens when the directional switch is returned to neutral. <p>Short circuit between P3 and P5.</p> <ul style="list-style-type: none"> Disconnect the wire from P5 and check for a short circuit between P3 and the wire that was connected to P5. <p>Defective control. Replace the controller unit.</p> | |

| TRACTION STATUS CODE | DESCRIPTION OF STATUS | CAUSE OF STATUS INDICATION |
|--|--|---|
| -05 | Start switch fails to close. | This status code will be displayed when P7 is less than 2.5 volts and P3 is less than 60% of battery volts. |
| MEMORY RECALL NO | CORRECTIVE ACTIONS | <u>TROUBLE-SHOOTING DIAGRAM</u> |
| Circuits valid for Traction Controller | <p><u>SYMPTOM</u> Control will not operate.</p> <p><u>POSSIBLE CAUSE</u> Defective start switch circuit.</p> <ul style="list-style-type: none"> • Check start switch to insure closure when accelerator is depressed. • Check for open circuit or loose connections in wiring from brake switch to start switch and from P3 to start switch. <p>Defective accelerator switch.</p> <ul style="list-style-type: none"> • Check accelerator switch potentiometer for proper operation and ohmic value. | |

| TRACTION STATUS CODE | DESCRIPTION OF STATUS | CAUSE OF STATUS INDICATION |
|--|--|--|
| -06 | Accelerator depressed with no direction selected. | This status code will be displayed when P4 and P5 are less than 60% of battery volts, and P7 is less than 2.5 volts. |
| MEMORY RECALL NO | CORRECTIVE ACTIONS | <u>TROUBLE-SHOOTING DIAGRAM</u> |
| Circuits valid for Traction Controller | <p><u>SYMPTOM</u> Control will not operate.</p> <p><u>POSSIBLE CAUSE</u> Accelerator pedal is depressed before closing forward or reverse directional switch.</p> <ul style="list-style-type: none"> • Status code will disappear when directional switch is closed or when accelerator pedal is released. <p>Defective directional switch</p> <ul style="list-style-type: none"> • Check forward or reverse switch to insure closure when direction is selected. <p>Open circuit between directional switch(es) and battery positive or between directional switch(es) and P4 or P5.</p> <ul style="list-style-type: none"> • Check all control wires and connections shown in Trouble Shooting Diagram. | |

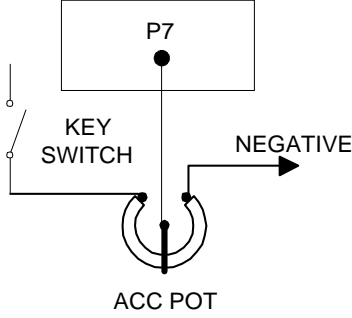
| TRACTION STATUS CODE | DESCRIPTION OF STATUS | CAUSE OF STATUS INDICATION |
|--|--|---|
| -07 | Accelerator input voltage too high on power up after initial key switch closure. | This status code will be displayed when the accelerator input voltage at P7 is higher than 4.2 volts, and a directional contactor is picked up. |
| MEMORY RECALL NO | CORRECTIVE ACTIONS | <u>TROUBLE-SHOOTING DIAGRAM</u> |
| Circuits valid for Traction Controller | <p>SYMPTOM Control will not operate when accelerator pedal is depressed or status code -07 is displayed then disappears when the vehicle starts to accelerate.</p> <p>POSSIBLE CAUSE Accelerator input mis-adjusted or defective.</p> <ul style="list-style-type: none"> • Input voltage at P7 should be less than 3.7 volts. Adjust or replace accelerator unit to insure that the voltage at P7 will vary from 3.5 volts to less than .5 volts when the pedal is depressed. <p>Open circuit between battery negative and P7 in accelerator input circuit.</p> <ul style="list-style-type: none"> • Check for broken wires or loose connections or open potentiometer / voltage supply. <p>Short circuit from battery positive to wiring in accelerator input circuit.</p> <ul style="list-style-type: none"> • Disconnect wire from P7 and measure voltage at wire to negative. Should be zero volts for potentiometer type and less than 3.7 volts for solid state type accelerator input. |  |

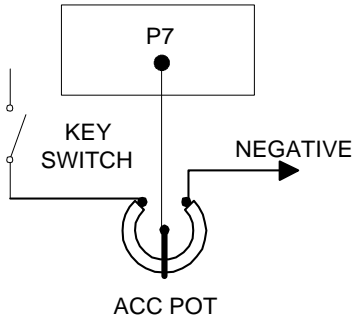
| TRACTION STATUS CODE | DESCRIPTION OF STATUS | CAUSE OF STATUS INDICATION |
|--|---|---|
| -08 | Accelerator input voltage too low on power up after initial key switch closure. | This status code will be displayed when the accelerator input voltage at P7 is less than 3.0 volts, and any of the following connections are opened and closed: battery plug or key switch. |
| MEMORY RECALL NO | CORRECTIVE ACTIONS | <u>TROUBLE-SHOOTING DIAGRAM</u> |
| Circuits valid for Traction Controller | <p>SYMPTOM Control will not operate.</p> <p>POSSIBLE CAUSE Accelerator input mis-adjusted or defective.</p> <ul style="list-style-type: none"> • Input voltage at P7 should be more than 3.0 volts. Adjust or replace accelerator unit to insure that the voltage at P7 is more than 3.0 volts before depressing pedal. <p>Short circuit between battery negative and P7 in accelerator input circuit.</p> <ul style="list-style-type: none"> • Disconnect wire from P7. Check for short circuit from wire to battery negative. <p>Defective Control</p> <ul style="list-style-type: none"> • Disconnect wire from P7. Measure voltage from P7 to negative. Voltage should be greater than 4.5 volts, if not, replace control. |  |

| TRACTION STATUS CODE | DESCRIPTION OF STATUS | CAUSE OF STATUS INDICATION |
|--|--|---|
| -09 | Both the forward and reverse directional switches are closed at the same time. | This status code will be displayed when P4 and P5 are greater than 60% of battery volts at the same time. |
| MEMORY RECALL NO | CORRECTIVE ACTIONS | TROUBLE-SHOOTING DIAGRAM |
| Circuits valid for Traction Controller | <p>SYMPTOM Control will not operate.</p> <p>POSSIBLE CAUSE Forward or reverse directional switch welded closed or mis-adjusted to be held closed.</p> <ul style="list-style-type: none"> • Replace or adjust directional switches to insure that they open when directional switch is returned to neutral. <p>Short circuit between battery positive and P4 and/or P5.</p> <ul style="list-style-type: none"> • Disconnect wires from P4 and P5 and check wire for short circuit to positive side of directional switch. <p>Defective Control</p> <ul style="list-style-type: none"> • Disconnect wires and measure voltage at P4 and P5. Voltage should be less than 60% of battery volts. | |

| TRACTION STATUS CODE | DESCRIPTION OF STATUS | CAUSE OF STATUS INDICATION |
|--|--|--|
| -10 | Steer angle potentiometer voltage is too high. | This status code will be displayed when P12 is greater than 3.9 volts. |
| MEMORY RECALL YES | CORRECTIVE ACTIONS | TROUBLE-SHOOTING DIAGRAM |
| Circuits valid for Traction Controller | <p>SYMPTOM Control will not operate.</p> <p>POSSIBLE CAUSE Steer angle potentiometer input mis-adjusted or defective. Loose or missing connections at P8, P12 or P9.</p> <ul style="list-style-type: none"> • Input voltage at P12 should be less than 3.9 volts at all times. Insure that the adjustment of the steer potentiometer is in accordance with Section 9 of this instruction. | |

| TRACTION STATUS CODE | DESCRIPTION OF STATUS | CAUSE OF STATUS INDICATION |
|--|---|--|
| -11 | Start switch closed on power up after initial key switch closure. | This status code will be displayed when P3 is greater than 60% of battery voltage when the key switch is closed. |
| MEMORY RECALL NO | CORRECTIVE ACTIONS | TROUBLE-SHOOTING DIAGRAM |
| Circuits valid for Traction Controller | <p>SYMPTOM Control will not operate.</p> <p>POSSIBLE CAUSE Start switch input mis-adjusted or defective.</p> <ul style="list-style-type: none"> Input voltage at P3 should be less than 60% of battery volts at key switch closing. Adjust or replace accelerator unit to insure that the voltage at P3 is less than 60% of battery volts before closing the start switch. <p>Short circuit between battery positive and P3 in start switch input circuit.</p> <ul style="list-style-type: none"> Disconnect wire from P3. Check for short circuit from this wire to battery positive. <p>Defective control.</p> <ul style="list-style-type: none"> Disconnect wire from P3. Measure voltage from P3 to negative. Voltage should be zero, if not, replace control. | |

| TRACTION STATUS CODE | DESCRIPTION OF STATUS | CAUSE OF STATUS INDICATION |
|--|--|--|
| -12 | Steer angle potentiometer voltage is too low. | This status code will be displayed when P12 is less than 0.39 volts. |
| MEMORY RECALL YES | CORRECTIVE ACTIONS | TROUBLE-SHOOTING DIAGRAM |
| Circuits valid for Traction Controller | <p>SYMPTOM Control will not operate.</p> <p>POSSIBLE CAUSE Steer angle potentiometer input mis-adjusted or defective. Loose or missing connections at P9, P12 or P8.</p> <ul style="list-style-type: none"> Input voltage at P12 should be greater than 0.39 volts at all times. Insure that the adjustment of the steer potentiometer is in accordance with Section 9 of this instruction. | |

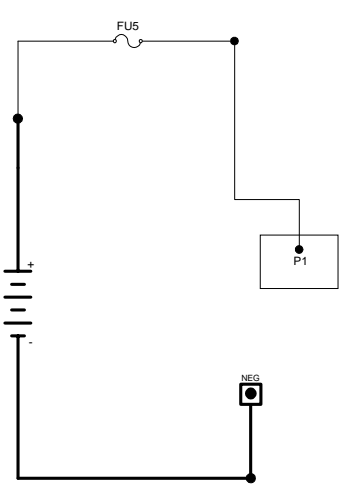
| TRACTION STATUS CODE | DESCRIPTION OF STATUS | CAUSE OF STATUS INDICATION | | | | | | | | | | | | |
|--|--|---|-------------------------|--|----|------|----|------|----|------|----|------|----|------|
| -15 | Battery voltage is too low or control card is mis-adjusted. | This status code will be displayed when the battery volts are less than 1.95 volts per cell at initial key switch on. See table below. | | | | | | | | | | | | |
| MEMORY RECALL NO | CORRECTIVE ACTIONS | TROUBLE-SHOOTING DIAGRAM | | | | | | | | | | | | |
| Circuits valid for Traction Controller | <p>SYMPTOM Control will not operate.</p> <p>POSSIBLE CAUSE Discharged battery</p> <ul style="list-style-type: none"> Check battery for proper open circuit voltage as shown in "Trouble Shooting Diagram", charge battery, if required. <p>Defective battery</p> <ul style="list-style-type: none"> Check each battery cell for proper voltage (greater than 1.95 volts at cell). Replace or repair battery. <p>Incorrect control card adjustment.</p> <ul style="list-style-type: none"> Check Function 15 for proper adjustment for battery being used. See Handset instruction sheet for details. Adjust to proper settings. <p>Check "minimum" battery volts at P1 and NEG.</p> |  <table border="1" data-bbox="1266 483 1494 714"> <thead> <tr> <th>NOMINAL BATTERY VOLTAGE</th> <th>MINIMUM LIMIT VOLTS AT 1.95 VDC PER CELL</th> </tr> </thead> <tbody> <tr> <td>24</td> <td>23.4</td> </tr> <tr> <td>36</td> <td>35.1</td> </tr> <tr> <td>48</td> <td>46.8</td> </tr> <tr> <td>72</td> <td>70.2</td> </tr> <tr> <td>80</td> <td>78.0</td> </tr> </tbody> </table> | NOMINAL BATTERY VOLTAGE | MINIMUM LIMIT VOLTS AT 1.95 VDC PER CELL | 24 | 23.4 | 36 | 35.1 | 48 | 46.8 | 72 | 70.2 | 80 | 78.0 |
| NOMINAL BATTERY VOLTAGE | MINIMUM LIMIT VOLTS AT 1.95 VDC PER CELL | | | | | | | | | | | | | |
| 24 | 23.4 | | | | | | | | | | | | | |
| 36 | 35.1 | | | | | | | | | | | | | |
| 48 | 46.8 | | | | | | | | | | | | | |
| 72 | 70.2 | | | | | | | | | | | | | |
| 80 | 78.0 | | | | | | | | | | | | | |

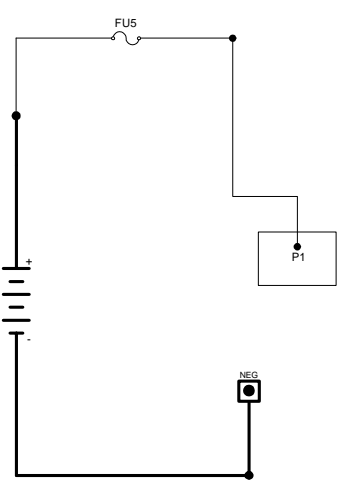
| TRACTION STATUS CODE | DESCRIPTION OF STATUS | CAUSE OF STATUS INDICATION | | | | | | | | | | | | |
|--|---|--|-------------------------|--|----|------|----|------|----|------|----|------|----|-------|
| -16 | Battery voltage is too high or control card is mis-adjusted. | This status code will be displayed when the battery volts are greater than 2.4 volts per cell at initial key switch on. See table below. | | | | | | | | | | | | |
| MEMORY RECALL NO | CORRECTIVE ACTIONS | TROUBLE-SHOOTING DIAGRAM | | | | | | | | | | | | |
| Circuits valid for Traction Controller | <p>SYMPTOM Control will not operate.</p> <p>POSSIBLE CAUSE Incorrect control card adjustment Check Function 15 for proper adjustment for battery being used. See Handset instructions for details. Adjust to proper setting.</p> <p>Battery over charged or incorrect battery used.</p> <ul style="list-style-type: none"> Check battery for proper open circuit voltage per table at right. If voltage is excessive, check battery charger for proper output voltage. <p>Check "maximum" battery volts at P1 and NEG.</p> |  <table border="1" data-bbox="1266 1386 1494 1617"> <thead> <tr> <th>NOMINAL BATTERY VOLTAGE</th> <th>MAXIMUM LIMIT VOLTS AT 1.95 VDC PER CELL</th> </tr> </thead> <tbody> <tr> <td>24</td> <td>28.8</td> </tr> <tr> <td>36</td> <td>43.2</td> </tr> <tr> <td>48</td> <td>57.6</td> </tr> <tr> <td>72</td> <td>86.4</td> </tr> <tr> <td>80</td> <td>100.8</td> </tr> </tbody> </table> | NOMINAL BATTERY VOLTAGE | MAXIMUM LIMIT VOLTS AT 1.95 VDC PER CELL | 24 | 28.8 | 36 | 43.2 | 48 | 57.6 | 72 | 86.4 | 80 | 100.8 |
| NOMINAL BATTERY VOLTAGE | MAXIMUM LIMIT VOLTS AT 1.95 VDC PER CELL | | | | | | | | | | | | | |
| 24 | 28.8 | | | | | | | | | | | | | |
| 36 | 43.2 | | | | | | | | | | | | | |
| 48 | 57.6 | | | | | | | | | | | | | |
| 72 | 86.4 | | | | | | | | | | | | | |
| 80 | 100.8 | | | | | | | | | | | | | |

| TRACTION STATUS CODE | DESCRIPTION OF STATUS | CAUSE OF STATUS INDICATION |
|--|--|--|
| -23 | Motor field current is high on start up in the reverse direction. | This status code will be displayed when the offset voltage is too high at start up in the reverse direction. |
| MEMORY RECALL NO | CORRECTIVE ACTIONS | <u>TROUBLE-SHOOTING DIAGRAM</u> |
| Circuits valid for Traction Controller | <p><u>SYMPTOM</u> Control will not operate.</p> <p><u>POSSIBLE CAUSE</u> Defective control.</p> <ul style="list-style-type: none"> • Replace controller unit. | |

| TRACTION STATUS CODE | DESCRIPTION OF STATUS | CAUSE OF STATUS INDICATION |
|--|--|--|
| -24 | Motor field current is high on start up in the forward direction. | This status code will be displayed when the offset voltage is too high at start up in the forward direction. |
| MEMORY RECALL NO | CORRECTIVE ACTIONS | <u>TROUBLE-SHOOTING DIAGRAM</u> |
| Circuits valid for Traction Controller | <p><u>SYMPTOM</u> Control will not operate.</p> <p><u>POSSIBLE CAUSE</u> Defective Control.</p> <ul style="list-style-type: none"> • Replace controller unit. | |

| TRACTION STATUS CODE | DESCRIPTION OF STATUS | CAUSE OF STATUS INDICATION |
|--|--|---|
| -27 | Control's power supply is less than 10 Volts DC. | This status code will be displayed when the control's power supply is less than 10 volts. |
| MEMORY RECALL YES | CORRECTIVE ACTIONS | <u>TROUBLE-SHOOTING DIAGRAM</u> |
| Circuits valid for Traction Controller | <p><u>SYMPTOM</u> Line contactor opens and closes, then can only be closed by opening and closing the key switch.</p> <p><u>POSSIBLE CAUSE</u> Discharged Battery</p> <ul style="list-style-type: none"> • Check battery to insure proper state of charge. Voltage may be dropping below 10 Volts DC under load. <p>Loose connection at P1.</p> <ul style="list-style-type: none"> • Insure that the wire connection at P1 is tight. | |

| TRACTION STATUS CODE | DESCRIPTION OF STATUS | CAUSE OF STATUS INDICATION |
|--|--|---|
| -28 | Motor field current is too high during the run mode. | This status code will be displayed when the current draw in the motor field is sustained above a preset limit for longer than 70 seconds. |
| MEMORY RECALL YES | CORRECTIVE ACTIONS | <u>TROUBLE-SHOOTING DIAGRAM</u> |
| Circuits valid for Traction Controller | <p><u>SYMPTOM</u> Control will not operate.</p> <p><u>POSSIBLE CAUSE</u> Continued operation of vehicle in high motor current condition.</p> <ul style="list-style-type: none"> • Operate vehicle at lower motor current condition for 70 seconds. <p>Function 7 is mis-adjusted to allow higher than normal motor field current. Adjust function per OEM instructions.</p> | <p><i>THE PRESENCE OF THIS STATUS CODE IS NOT NECESSARILY INDICATIVE OF A CONTROL ISSUE. THIS STATUS CODE MAY INDICATE AN APPLICATION ISSUE. DISPLAY OF THIS STATUS CODE SHOULD NOT TRIGGER THE RETURN OF A CONTROL FOR REPAIR OR REPLACEMENT.</i></p> |

| TRACTION STATUS CODE | DESCRIPTION OF STATUS | CAUSE OF STATUS INDICATION |
|--|--|---|
| -29 | Motor field current is too high during the run mode (Dual motor proportioning controls only) | This status code will be displayed when the motor current in control "A" is greater than 98A, while the motor current in control "B" is less than 26A for a 16 second interval. |
| MEMORY RECALL YES | CORRECTIVE ACTIONS | |
| Circuits valid for Traction Controller | SYMPTOM Control will not operate. | POSSIBLE CAUSE Continued operation of vehicle in high motor current condition. • Verify operation of other control during the run mode. |

TROUBLE-SHOOTING DIAGRAM

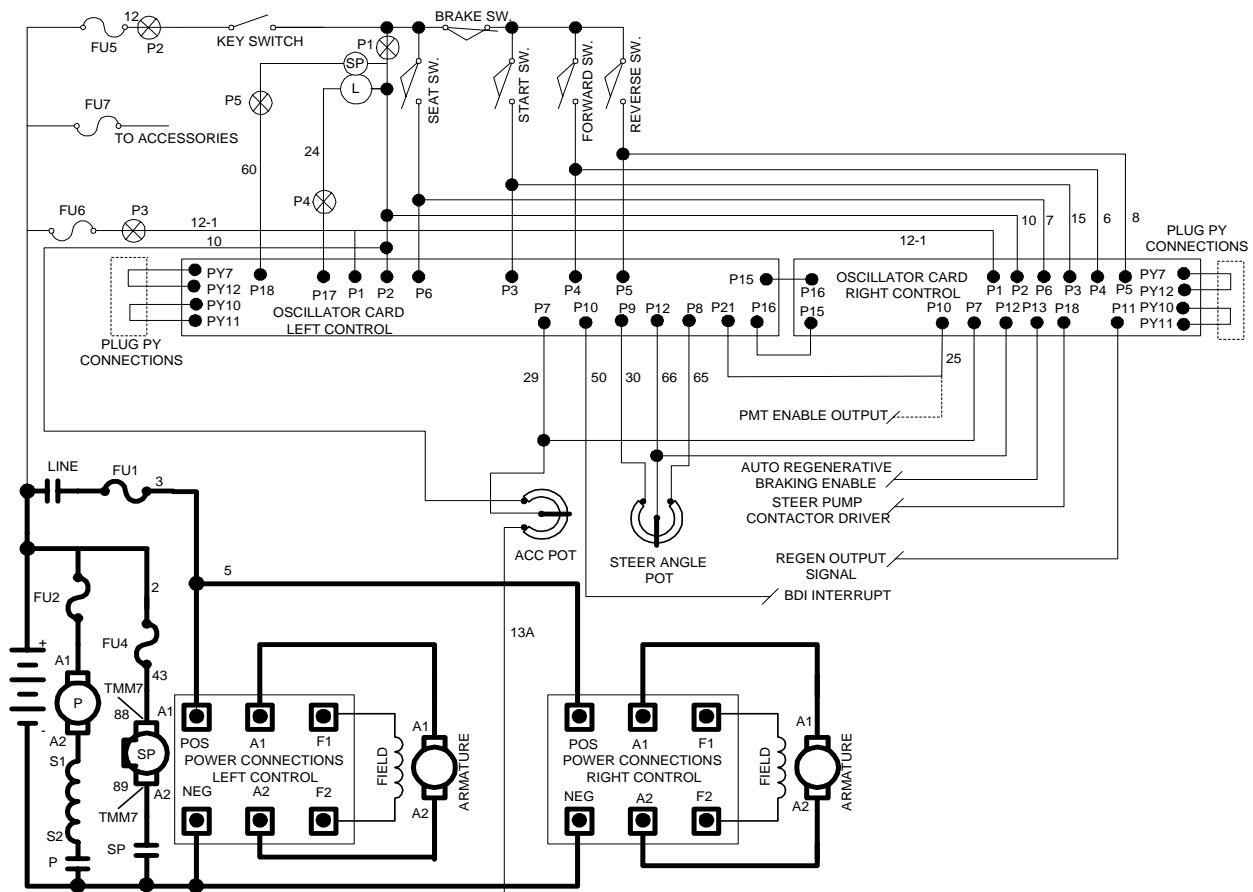

| TRACTION STATUS CODE | DESCRIPTION OF STATUS | CAUSE OF STATUS INDICATION |
|--|---|--|
| -30 | PMT enable signal from auxiliary control to master at PL21 is missing during SRO check (Dual motor proportioning controls only) | This status code will be displayed when the voltage at PL21 of the master control is less than 5 volts. This fault is not stored. |
| MEMORY RECALL NO | CORRECTIVE ACTIONS | |
| Circuits valid for Traction Controller | SYMPTOM Auxiliary control shutdown. | POSSIBLE CAUSE <ul style="list-style-type: none"> • Check auxiliary control for status codes. • Verify connection between PL21 of the master control and PL10 of the slave/auxiliary control. |

TROUBLE-SHOOTING DIAGRAM

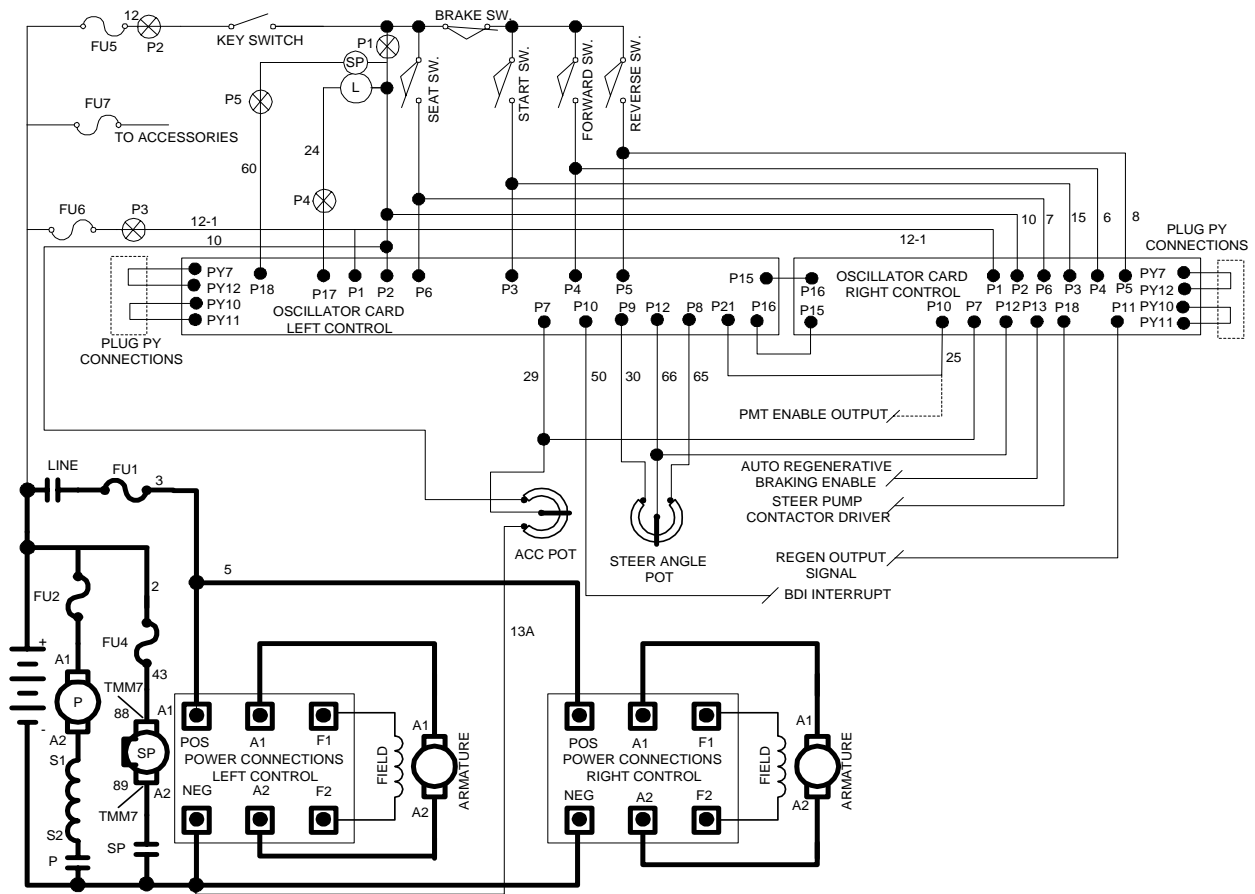

| | | |
|---|---|---|
| <p>-41</p> | <p>Open thermal protector (TP) or transistor over temperature.</p> | <p>This status code will be displayed when the voltage at the thermal protector is too high.</p> |
| <p>MEMORY RECALL YES *</p> | <p>CORRECTIVE ACTIONS</p> | <p><u>TROUBLE-SHOOTING DIAGRAM</u></p> |
| <p>Circuits valid for Traction Controller</p> | <p><u>SYMPTOM</u> Reduced or no power to traction motor in control range.</p> <p><u>POSSIBLE CAUSE</u> Control is in thermal cut-back.</p> <ul style="list-style-type: none"> • Allow control to cool, status code should disappear. • Insufficient heat transfer may be occurring between control and mounting surface. Refer to control mounting guidelines in section 4.4 of this manual. <p>* First status code displayed immediately, additional codes displayed in 20 hour intervals.</p> | <p><i>THE PRESENCE OF THIS STATUS CODE IS NOT NECESSARILY INDICATIVE OF A CONTROL ISSUE. THIS STATUS CODE MAY INDICATE AN APPLICATION ISSUE. DISPLAY OF THIS STATUS CODE SHOULD NOT TRIGGER THE RETURN OF A CONTROL FOR REPAIR OR REPLACEMENT.</i></p> |

| TRACTION STATUS CODE | DESCRIPTION OF STATUS | CAUSE OF STATUS INDICATION |
|---|--|--|
| <p>-42</p> | <p>Motor armature offset voltage is too high.</p> | <p>This status code will be displayed when the voltage at the current sensor input is greater than 2.6 volts with no current flowing in the motor circuit.</p> |
| <p>MEMORY RECALL NO</p> | <p>CORRECTIVE ACTIONS</p> | <p><u>TROUBLE-SHOOTING DIAGRAM</u></p> |
| <p>Circuits valid for Traction Controller</p> | <p><u>SYMPTOM</u> Control will not operate.</p> <p><u>POSSIBLE CAUSE</u> Defective control.</p> <ul style="list-style-type: none"> • Replace controller unit. | |

| TRACTION STATUS CODE | DESCRIPTION OF STATUS | CAUSE OF STATUS INDICATION |
|--|--|--|
| -43 | Motor armature offset voltage is too low. | This status code will be displayed when the voltage at the current sensor input is less than 2.4 volts with no current flowing in the motor circuit. |
| MEMORY RECALL NO | CORRECTIVE ACTIONS | TROUBLE-SHOOTING DIAGRAM |
| Circuits valid for Traction Controller | <p>SYMPTOM Control will not operate.</p> <p>POSSIBLE CAUSE Defective control.</p> <ul style="list-style-type: none"> • Replace controller unit. | |

| TRACTION STATUS CODE | DESCRIPTION OF STATUS | CAUSE OF STATUS INDICATION |
|--|--|--|
| -44 | Armature transistor did not turn off properly. | This status code will be displayed when, during control operation, the armature transistor fails to turn off. This will result in a PMT condition. |
| MEMORY RECALL YES | CORRECTIVE ACTIONS | TROUBLE-SHOOTING DIAGRAM |
| Circuits valid for Traction Controller | <p>SYMPTOM Status code will be displayed during control operation and can only be re-set by recycling the key switch.</p> <p>POSSIBLE CAUSE The presence of a SC44 in a master control and SC66 in a slave control simultaneously could indicate:</p> <ul style="list-style-type: none"> • Excessive overheating in the control and motor due to an application issue. Allow the system to cool, and the status codes will no longer be displayed. • a loose or missing wire between P21 (on the master) and P10 (on the slave), when the status codes occur during run mode | |

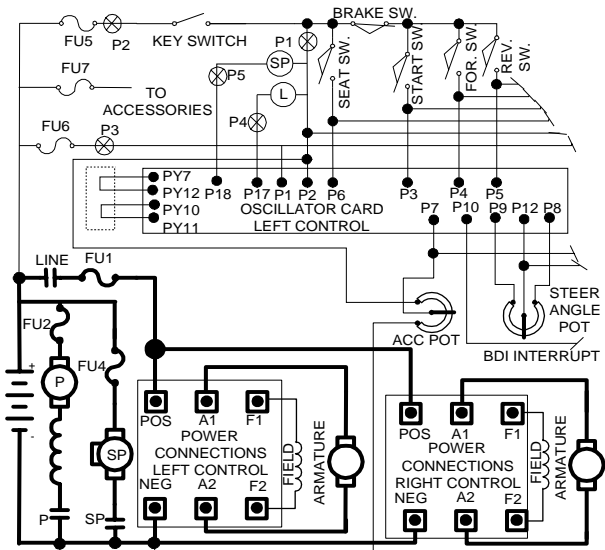
| TRACTION STATUS CODE | DESCRIPTION OF STATUS | CAUSE OF STATUS INDICATION |
|--|--|--|
| -45 | Armature transistor did not turn on properly. | This status code will be displayed when, during control operation, the armature transistor fails to turn on properly. This will result in a PMT condition. |
| MEMORY RECALL YES | CORRECTIVE ACTIONS | TROUBLE-SHOOTING DIAGRAM |
| Circuits valid for Traction Controller | <p>SYMPTOM Line contactor opens and closes, then can only be closed by opening and closing the key switch.</p> <p>POSSIBLE CAUSE Defective control.</p> <ul style="list-style-type: none"> • Replace controller unit. |  |

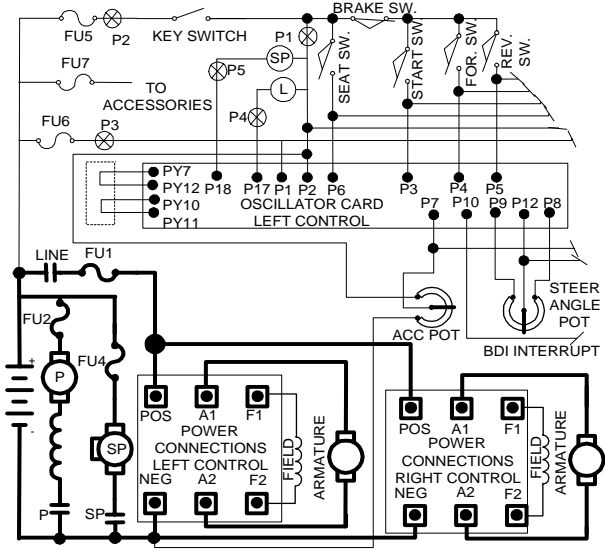
| TRACTION STATUS CODE | DESCRIPTION OF STATUS | CAUSE OF STATUS INDICATION |
|--|--|--|
| -46 | "Look Ahead" test for A2 volts less than 12% of battery volts. | This status code will be displayed when the voltage at A2 is less than 12% of battery volts. |
| MEMORY RECALL NO | CORRECTIVE ACTIONS | TROUBLE-SHOOTING DIAGRAM |
| Circuits valid for Traction Controller | <p>SYMPTOM Line contactor opens and closes, then opens, and can only close by opening and closing the key switch.</p> <p>POSSIBLE CAUSE Check for short circuit from the motor armature to the frame of the vehicle.</p> |  |

| TRACTION STATUS CODE | DESCRIPTION OF STATUS | CAUSE OF STATUS INDICATION |
|--|--|---|
| -49 | Motor field current is too low during the run mode. | This status code will be displayed when the current draw in the motor field is too low during the run mode. |
| MEMORY RECALL YES | CORRECTIVE ACTIONS | TROUBLE-SHOOTING DIAGRAM |
| Circuits valid for Traction Controller | <p>SYMPTOM Control will only operate for a second or two before shutting down.</p> <p>POSSIBLE CAUSE If the fault code is intermittent, verify that the accelerator pot is adjusted correctly.</p> <p>Check for open motor field coils or loose or intermittent field connections, or open F1 or F2 connections.</p> | |

| TRACTION STATUS CODE | DESCRIPTION OF STATUS | CAUSE OF STATUS INDICATION |
|--|--|---|
| -51 | Capacitor volts are low before the line contactor closes. | This status code will be displayed during "key on" when the capacitor voltage is less than 85% of battery volts at initial key switch on. |
| MEMORY RECALL NO | CORRECTIVE ACTIONS | TROUBLE-SHOOTING DIAGRAM |
| Circuits valid for Traction Controller | <p>SYMPTOM Line contactor does not close when capacitor does not precharge.</p> <p>POSSIBLE CAUSE Defective control fuse.</p> <ul style="list-style-type: none"> • Check control fuse for open circuit. Replace fuse, if necessary. <p>Loose connector at P1.</p> <ul style="list-style-type: none"> • Verify connection at P1. <p>Verify that no external load has been added to the low side of the line contactor.</p> <p><i>Note: Repeated "charging/discharging" the capacitors during troubleshooting will cause status code 51.</i></p> | |

| TRACTION STATUS CODE | DESCRIPTION OF STATUS | CAUSE OF STATUS INDICATION |
|--|--|--|
| -57 | Controller "motor current sensor" input too low during running. | This status code will be displayed when the voltage input from the current sensor is too low during running. |
| MEMORY RECALL YES | CORRECTIVE ACTIONS | TROUBLE-SHOOTING DIAGRAM |
| Circuits valid for Traction Controller | <p>SYMPTOM Control will not operate.</p> <p>POSSIBLE CAUSE Defective control.</p> <ul style="list-style-type: none"> • Replace controller unit. | |

| TRACTION STATUS CODE | DESCRIPTION OF STATUS | CAUSE OF STATUS INDICATION |
|--|---|---|
| -64 | The line driver input (P2-17) is less than 12% of battery volts | This status code will be displayed when the control detects that the line driver input (P2-17) is less than 12% battery volts when the key switch is turned on. |
| MEMORY RECALL NO | CORRECTIVE ACTIONS | TROUBLE-SHOOTING DIAGRAM |
| Circuits valid for Traction Controller | <p>SYMPTOM Control will not operate.</p> <p>POSSIBLE CAUSE -Open wire connection to Pin 17 - Shorted line driver transistor</p> | |

| TRACTION STATUS CODE | DESCRIPTION OF STATUS | CAUSE OF STATUS INDICATION |
|--|--|--|
| -65 | The line coil current is too high during the run mode | This status code will be displayed when the current limit in the line coil is exceeded during the run mode. The line contactor will drop out and the key switch will have to be recycled to reset the control. |
| MEMORY RECALL YES | CORRECTIVE ACTIONS | <p><u>TROUBLE-SHOOTING DIAGRAM</u></p> |
| Circuits valid for Traction Controller | <p><u>SYMPTOM</u> Control will not operate.</p> <p><u>POSSIBLE CAUSE</u></p> <ul style="list-style-type: none"> - Shorted line contactor coil - Short between wires connected to line coil (wires #10 and 24) <p>If line coil resistance is correct: Defective control.</p> <ul style="list-style-type: none"> • Replace controller unit. | |

| TRACTION STATUS CODE | DESCRIPTION OF STATUS | CAUSE OF STATUS INDICATION |
|--|---|--|
| -66 | The field current exceeds the current limit of the field transistor. | This status code will be displayed when the field transistor exceeds its current limit. The line contactor will drop out and the key switch will have to be recycled to restart the control. |
| MEMORY RECALL YES | CORRECTIVE ACTIONS | TROUBLE-SHOOTING DIAGRAM |
| Circuits valid for Traction Controller | <p>SYMPTOM Control will not operate or is sluggish on start up. Line contactor opens.</p> <p>POSSIBLE CAUSES</p> <ul style="list-style-type: none"> • Shorted field F1 to F2 <ul style="list-style-type: none"> • F1 or F2 terminals shorted to battery positive (B+) or to battery negative (B-) • Binding line contactor <ul style="list-style-type: none"> • Visually inspect tips, clean them with a solvent. • Confirm that contactor includes G248 coil. • Master control has shut down unexpectedly, causing the line contactor to drop out, and the slave control stores the status code. • A SC66 in the slave, and a SC68 in the master control, while in neutral, could indicate a loose connection between P21 in the master and P10 in the slave. • Noise <ul style="list-style-type: none"> • Missing or damaged horn suppressor • Confirm that all inductive loads/accessories are suppressed. • Excessive motor and control heating (controls are in thermal cutback) <ul style="list-style-type: none"> • Refer to OEM engineering for mode settings for slower acceleration | <p>The diagram illustrates the electrical circuit for the traction controller. It shows the power supply path through fuses FU1, FU2, and FU4 to the line contactor. The control circuit includes a key switch, brake switch, seat switch, and start switch, all connected to the left and right control units. The left control unit has terminals for power (A1), field (F1), and negative (A2, F2). The right control unit has similar terminals. The diagram also shows connections for an oscillator card, steering angle pot, and BDI interrupt.</p> |

| TRACTION STATUS CODE | DESCRIPTION OF STATUS | CAUSE OF STATUS INDICATION |
|--|---|---|
| -67 | The armature current exceeds the armature transistor limit. | This status code will be displayed when the armature transistor exceeds its specific current limit. The control is reset by recycling the key switch. |
| MEMORY RECALL YES | CORRECTIVE ACTIONS | <u>TROUBLE-SHOOTING DIAGRAM</u> |
| Circuits valid for Traction Controller | <p><u>SYMPTOM</u> Control will not operate.</p> <p><u>POSSIBLE CAUSE</u></p> <ul style="list-style-type: none"> • Shorted motor armature A1 to A2 • Power cables may be shorted to each other (Measure at control terminals) • A1 to A2 terminals may be shorted to battery positive or negative | |

| TRACTION STATUS CODE | DESCRIPTION OF STATUS | CAUSE OF STATUS INDICATION |
|--|--|---|
| -68 | The PMT enable signal from the auxiliary (slave) control to the master control drops below 5V. | This status code will be displayed when the voltage at the master PL21 drops below 5V. |
| MEMORY RECALL YES | CORRECTIVE ACTIONS | |
| Circuits valid for Traction Controller | <p>SYMPTOM Control will not operate.</p> | <p>POSSIBLE CAUSE Auxiliary control shut down.</p> <ul style="list-style-type: none"> • Check auxiliary control for stored faults. <p>Verify connection between the master control P21 and the auxiliary/slave control P10.</p> |

TROUBLE-SHOOTING DIAGRAM

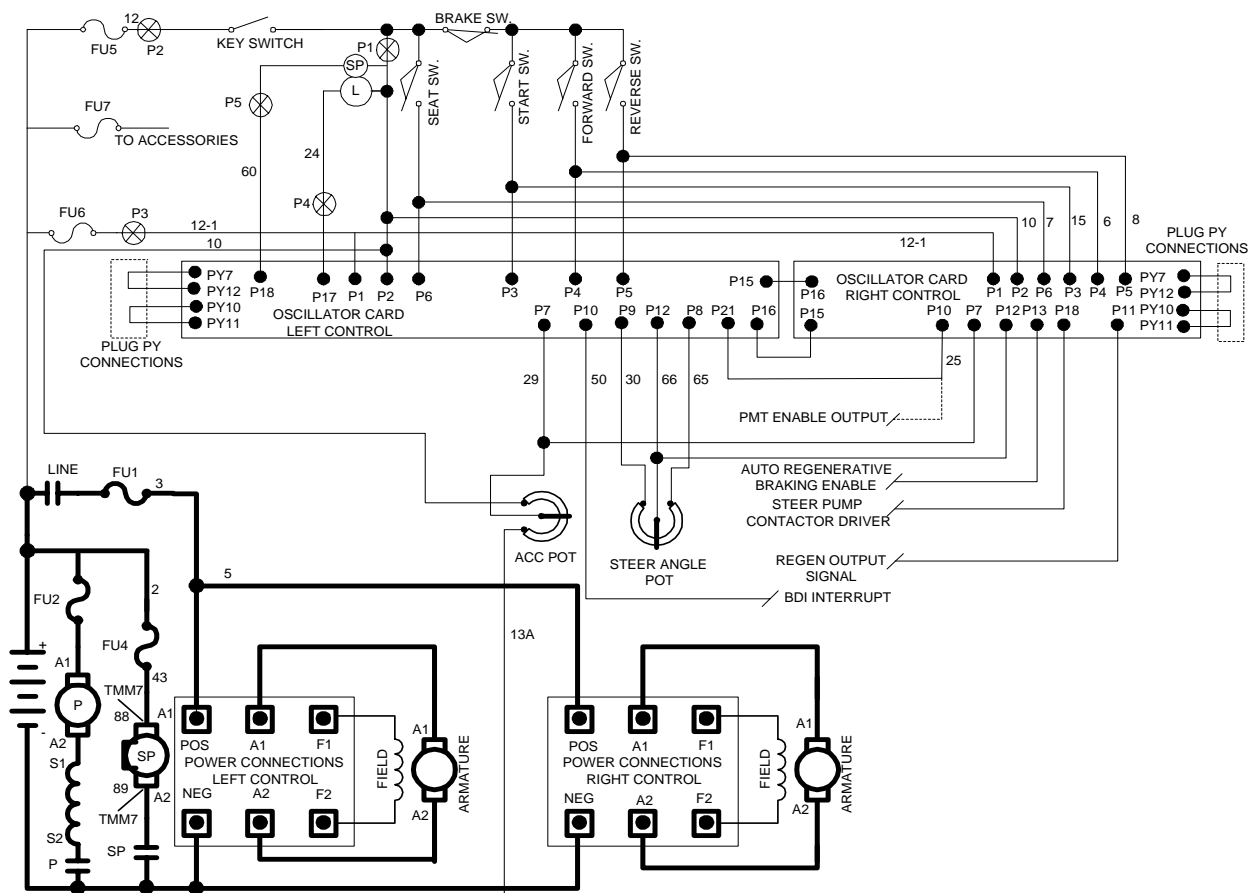

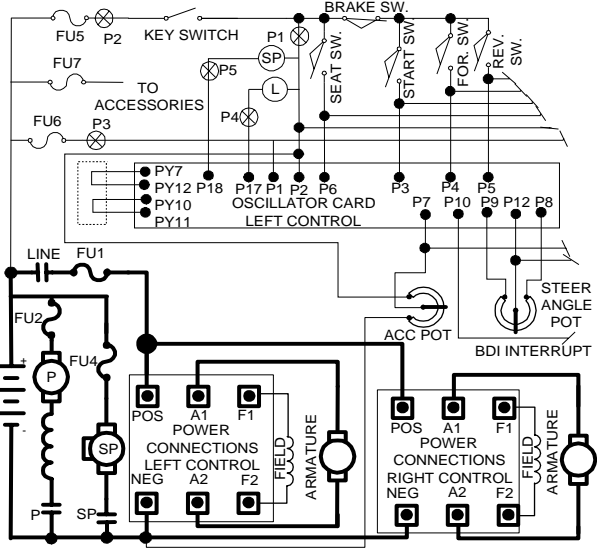
| TRACTION STATUS CODE | DESCRIPTION OF STATUS | CAUSE OF STATUS INDICATION |
|--|--|---|
| -69 | The power steering coil current is too high during the run mode. | This status code will be displayed when the current in the power steering driver circuit exceeds current limit during the run mode. The control is reset by recycling the key switch. |
| MEMORY RECALL YES | CORRECTIVE ACTIONS | TROUBLE-SHOOTING DIAGRAM |
| Circuits valid for Traction Controller | <p>SYMPTOM Control will not operate.</p> <p>POSSIBLE CAUSE</p> <ul style="list-style-type: none"> Shorted power steering control coil Short between wires connecting to the power steering coil (wire # 10 and 60) |  |

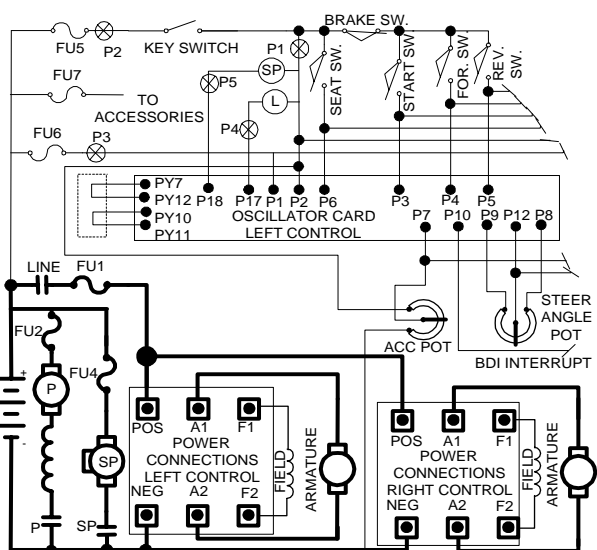
| TRACTION STATUS CODE | DESCRIPTION OF STATUS | CAUSE OF STATUS INDICATION | | | | | | | | |
|--|---|---|-------|-----|-----|-----|-----|-----|--------|--|
| -76 | Capacitor (1C) voltage too high. | This status code will be displayed when the voltage on the capacitor goes above limit voltage* during the regenerative braking cycle. | | | | | | | | |
| MEMORY RECALL YES | CORRECTIVE ACTIONS | TROUBLE-SHOOTING DIAGRAM | | | | | | | | |
| Circuits valid for Traction Controller | <p>SYMPTOM Line contactor opens and closes, then opens and can only close by opening and closing the key switch.</p> <p>POSSIBLE CAUSE</p> <ul style="list-style-type: none"> Unplugging the battery connector during regenerative braking. Line contactor bouncing open during regen. Main power fuse opening during regen. Intermittent battery plug connection. <p>* Limit Voltage:</p> <table border="1" data-bbox="454 1732 625 1837"> <thead> <tr> <th>Limit</th> <th>Batt.</th> </tr> </thead> <tbody> <tr> <td>50V</td> <td>36V</td> </tr> <tr> <td>70V</td> <td>48V</td> </tr> <tr> <td>96V</td> <td>72/80V</td> </tr> </tbody> </table> | Limit | Batt. | 50V | 36V | 70V | 48V | 96V | 72/80V |  |
| Limit | Batt. | | | | | | | | | |
| 50V | 36V | | | | | | | | | |
| 70V | 48V | | | | | | | | | |
| 96V | 72/80V | | | | | | | | | |

| TRACTION STATUS CODE | DESCRIPTION OF STATUS | CAUSE OF STATUS INDICATION |
|--|---|---|
| -77 | Motor current is detected during regenerative braking. | This status code will be displayed when motoring current is detected during the regenerative braking cycle. |
| MEMORY RECALL YES | CORRECTIVE ACTIONS | <u>TROUBLE-SHOOTING DIAGRAM</u> |
| Circuits valid for Traction Controller | <p><u>SYMPTOM</u> Line contactor opens and closes, then opens and can only close by opening and closing the key switch.</p> <p><u>POSSIBLE CAUSE</u> Defective control.</p> <ul style="list-style-type: none"> • Replace controller unit | |

| TRACTION STATUS CODE | DESCRIPTION OF STATUS | CAUSE OF STATUS INDICATION |
|--|--|---|
| -82 | When armature motor current is greater than 400 amps for more than 3.5 sec the armature motor current will be turned off. | This status code will be displayed when the armature motor current exceeds 400 amps for 3.5 sec and the accelerator pedal is calling for maximum performance. |
| MEMORY RECALL YES | CORRECTIVE ACTIONS | <u>TROUBLE-SHOOTING DIAGRAM</u> |
| Circuits valid for Traction Controller | <p><u>SYMPTOM</u> The Control will not operate, and can only be reset by cycling the key switch.</p> <p><u>POSSIBLE CAUSE:</u></p> <ul style="list-style-type: none"> • Continued operation of vehicle in high motor current condition • Operating control at stall motor current for more than 3.5 seconds. • Function 16 is incorrectly adjusted for control % on time. <ul style="list-style-type: none"> - Adjust function per OEM instructions | <p><i>THE PRESENCE OF THIS STATUS CODE IS NOT NECESSARILY INDICATIVE OF A CONTROL ISSUE. IF FUNCTION 16 IS NOT MIS-ADJUSTED, THE STATUS CODE INDICATES AN APPLICATION ISSUE WHERE A MOTOR IS BEING STALLED, ETC. DISPLAY OF THIS STATUS CODE SHOULD NOT TRIGGER THE RETURN OF A CONTROL FOR REPAIR OR REPLACEMENT.</i></p> |

Section 4.7 TMM Status Codes

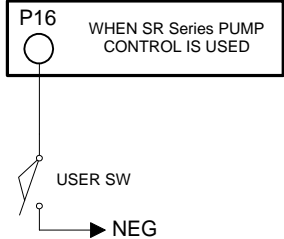
| TRACTION STATUS CODE | DESCRIPTION OF STATUS | CAUSE OF STATUS INDICATION |
|---|--|--|
| -90 | Traction motor temperature has exceeded maximum temperature limit. | This status code will be displayed when the voltage at the respective terminal of the TMM or Pump Logic Card is at zero volts. |
| MEMORY RECALL YES * | CORRECTIVE ACTIONS | <u>TROUBLE-SHOOTING DIAGRAM</u> |
| Circuits valid for Traction Motor Temperature | <p>SYMPTOM Status code flashes "on and off".</p> <p>POSSIBLE CAUSE User defined status code is displayed by switch closure to battery negative.</p> <p>Plug P16 (pump) is shorted to battery negative.</p> <p>Defective input switch (shorted).</p> <p>Defective TMM card.</p> <p>Defective pump card.</p> <p>* First status code displayed immediately, additional status codes displayed in 20 hour intervals.</p> |  <p style="text-align: right;">SC90</p> |

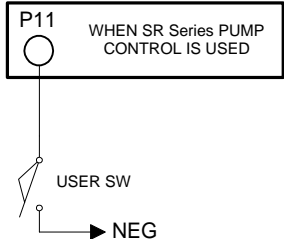
| TRACTION STATUS CODE | DESCRIPTION OF STATUS | CAUSE OF STATUS INDICATION |
|---|--|--|
| -91 | Pump motor temperature has exceeded maximum temperature limit. | This status code will be displayed when the voltage at the respective terminal of the TMM or Pump Logic Card is at zero volts. |
| MEMORY RECALL YES * | CORRECTIVE ACTIONS | <u>TROUBLE-SHOOTING DIAGRAM</u> |
| Circuits valid for Traction Motor Temperature | <p>SYMPTOM Status code flashes "on and off".</p> <p>POSSIBLE CAUSE User defined status code is displayed by switch closure to battery negative.</p> <p>Plug P11 (pump) is shorted to battery negative.</p> <p>Defective input switch (shorted).</p> <p>Defective TMM card.</p> <p>Defective pump card.</p> <p>* First status code displayed immediately, additional status codes displayed in 20 hour intervals.</p> |  <p style="text-align: right;">SC91</p> |

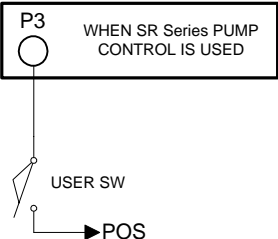
| TRACTION STATUS CODE | DESCRIPTION OF STATUS | CAUSE OF STATUS INDICATION |
|--|---|---|
| -93 | Steering pump motor brush wear indicator has detected worn brush. | This status code will be displayed when the voltage at the respective terminal of the TMM or Pump Logic Card is at battery volts. |
| MEMORY RECALL YES * | CORRECTIVE ACTIONS | <u>TROUBLE-SHOOTING DIAGRAM</u> |
| Circuits valid for Steer Pump Motor Brush Wear Indicator | <p>SYMPTOM Status code flashes "on and off".</p> <p>POSSIBLE CAUSE User defined status code is displayed by motor brush sensor closure to battery positive.</p> <p>Plug P3 (pump) is shorted to positive.</p> <p>Defective input switch (shorted).</p> <p>Defective TMM card.</p> <p>Defective pump card.</p> <p>* First status code displayed immediately, additional status codes displayed in 20 hour intervals.</p> |  <p style="text-align: right;">SC93</p> |

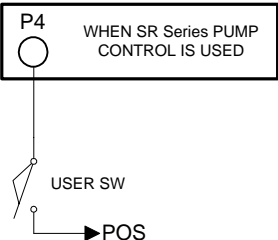
| TRACTION STATUS CODE | DESCRIPTION OF STATUS | CAUSE OF STATUS INDICATION |
|---|---|---|
| -93 | Steering pump motor brush wear indicator has detected worn brush. | This status code will be displayed when the voltage at the respective terminal of the TMM or Pump Logic Card is at battery volts. |
| MEMORY RECALL YES * | CORRECTIVE ACTIONS | <u>TROUBLE-SHOOTING DIAGRAM</u> |
| Circuits valid for Steering Pump Motor Brush Wear Indicator | <p>SYMPTOM Status code flashes "on and off".</p> <p>POSSIBLE CAUSE User defined status code is displayed by motor brush sensor closure to battery positive.</p> <p>Plug P4 (pump) is shorted to positive.</p> <p>Defective input switch (shorted).</p> <p>Defective TMM card.</p> <p>Defective pump card.</p> <p>* First status code displayed immediately, additional status codes displayed in 20 hour intervals.</p> |  <p style="text-align: right;">SC93A</p> |

| TRACTION STATUS CODE | DESCRIPTION OF STATUS | CAUSE OF STATUS INDICATION |
|--|---|---|
| -94 | Traction motor brush wear indicator has detected worn brush. | This status code will be displayed when the voltage at the respective terminal of the TMM or Pump Logic Card is at battery volts. |
| MEMORY RECALL YES * | CORRECTIVE ACTIONS | <u>TROUBLE-SHOOTING DIAGRAM</u> |
| Circuits valid for Traction Motor Brush Wear Indicator | <p>SYMPTOM Status code flashes "on and off".</p> <p>POSSIBLE CAUSE User defined status code is displayed by motor brush sensor closure to battery positive.</p> <p>Plug P5 (pump) is shorted to positive.</p> <p>Defective input switch (shorted).</p> <p>Defective TMM card.</p> <p>Defective pump card.</p> <p>* First status code displayed immediately, additional status codes displayed in 20 hour intervals.</p> | <p style="text-align: right;">SC94</p> |

| TRACTION STATUS CODE | DESCRIPTION OF STATUS | CAUSE OF STATUS INDICATION |
|--|---|--|
| -94 | Traction motor brush wear indicator had detected worn brush. | This status code will be displayed when the voltage at the respective terminal of the TMM or Pump Logic Card is at zero volts. |
| MEMORY RECALL YES * | CORRECTIVE ACTIONS | <u>TROUBLE-SHOOTING DIAGRAM</u> |
| Circuits valid for Traction Motor Brush Wear | <p>SYMPTOM Status code flashes "on and off".</p> <p>POSSIBLE CAUSE User defined status code is displayed by motor brush sensor closure to battery positive.</p> <p>Plug P6 (pump) is shorted to positive.</p> <p>Defective input switch (shorted).</p> <p>Defective TMM card.</p> <p>Defective pump card.</p> <p>* First status code displayed immediately, additional status codes displayed in 20 hour intervals.</p> | <p style="text-align: right;">SC94A</p> |

| TRACTION STATUS CODE | DESCRIPTION OF STATUS | CAUSE OF STATUS INDICATION |
|--|---|---|
| -95 | Pump motor brush wear indicator has detected worn brush. | This status code will be displayed when the voltage at the respective terminal of the TMM or Pump Logic Card is at battery volts. |
| MEMORY RECALL YES * | CORRECTIVE ACTIONS | <u>TROUBLE-SHOOTING DIAGRAM</u> |
| Circuits valid for Pump Motor Brush Wear Indicator | <p>SYMPTOM Status code flashes "on and off".</p> <p>POSSIBLE CAUSE User defined status code is displayed by motor brush sensor closure to battery positive.</p> <p>Plug P8 (pump) is shorted to positive.</p> <p>Defective input switch (shorted).</p> <p>Defective TMM card.</p> <p>Defective pump card.</p> <p>* First status code displayed immediately, additional status codes displayed in 20 hour intervals.</p> | |

SC95

| TRACTION STATUS CODE | DESCRIPTION OF STATUS | CAUSE OF STATUS INDICATION |
|--|---|---|
| -95 | Pump motor brush wear indicator has detected worn brush. | This status code will be displayed when the voltage at the respective terminal of the TMM or Pump Logic Card is at battery volts. |
| MEMORY RECALL YES * | CORRECTIVE ACTIONS | <u>TROUBLE-SHOOTING DIAGRAM</u> |
| Circuits valid for Pump Motor Brush Wear Indicator | <p>SYMPTOM Status code flashes "on and off".</p> <p>POSSIBLE CAUSE User defined status code is displayed by motor brush sensor closure to battery positive.</p> <p>Plug P9 (pump) is shorted to positive.</p> <p>Defective input switch (shorted).</p> <p>Defective TMM card.</p> <p>Defective pump card.</p> <p>* First status code displayed immediately, additional status codes displayed in 20 hour intervals.</p> | |

SC95A

| TRACTION STATUS CODE | DESCRIPTION OF STATUS | CAUSE OF STATUS INDICATION |
|--|---|--|
| -99 | Maintenance alert and speed limit. | This status code will be displayed when the "normal" hour meter exceeds the "maintenance alert hours" setting for the vehicle. |
| MEMORY RECALL YES * | CORRECTIVE ACTIONS | <u>TROUBLE-SHOOTING DIAGRAM</u> |
| Circuits valid for Traction Controller | <p><u>SYMPTOM</u> Status code is displayed for 4 seconds when the key switch is first turned on, and/or the vehicle may run at a reduced speed.</p> <p><u>CUSTOMER SELECTED SETTING WITH THE HANDSET:</u> User defined status code is displayed when the normal hour meter reading exceeds the programmed "maintenance alert hours" setting selected by the user</p> <ul style="list-style-type: none"> • Maintenance Code Hour Meter, Functions 19 and 20, are programmed with the Handset and command the display of status code -99. • If desired, Maintenance Code Speed Limit, Function 13, can be programmed with the Handset. <p>User should perform the desired maintenance function. Re-set maintenance alert hour meter after maintenance is performed.</p> <p>* First status code displayed immediately, additional status codes displayed in 20 hour intervals.</p> | <p><u>NO DIAGRAM</u></p> <p>USER SHOULD PERFORM THE DESIRED MAINTENANCE FUNCTION</p> |

Section 4.8 Pump Control Codes

| PUMP STATUS CODE | DESCRIPTION OF STATUS | CAUSE OF STATUS INDICATION |
|------------------------------------|---|--|
| -117 | "Card Type" selection is invalid. | This status code will be displayed when the card type selection value is set to an invalid number. |
| MEMORY RECALL NO | CORRECTIVE ACTIONS | <u>TROUBLE-SHOOTING DIAGRAM</u> |
| Circuits valid for Pump Controller | <p><u>SYMPTOM</u> Control will not operate.</p> <p><u>POSSIBLE CAUSE</u> Invalid card type selection.</p> <ul style="list-style-type: none"> Review function 17 in the Handset Instruction sheets. Adjust and set card type value as instructed by OEM service manual. | <p>NO GRAPHIC FOR THIS STATUS CODE</p> |

| PUMP STATUS CODE | DESCRIPTION OF STATUS | CAUSE OF STATUS INDICATION |
|------------------------------------|--|---|
| -127 | Control logic card power supply is less than 10 VDC. | This status code is displayed when the logic card power supply is less than 10 volts. |
| MEMORY RECALL YES | CORRECTIVE ACTIONS | <u>TROUBLE-SHOOTING DIAGRAM</u> |
| Circuits valid for Pump Controller | <p><u>SYMPTOM</u> Control will not operate.</p> <p><u>POSSIBLE CAUSE</u></p> <p>Discharged Battery</p> <ul style="list-style-type: none"> Check battery to insure proper state of charge. <p>Loose connection at P1.</p> <ul style="list-style-type: none"> Insure that the wire connection at P1 is tight. <p>Defective logic card</p> <ul style="list-style-type: none"> Replace control. | |

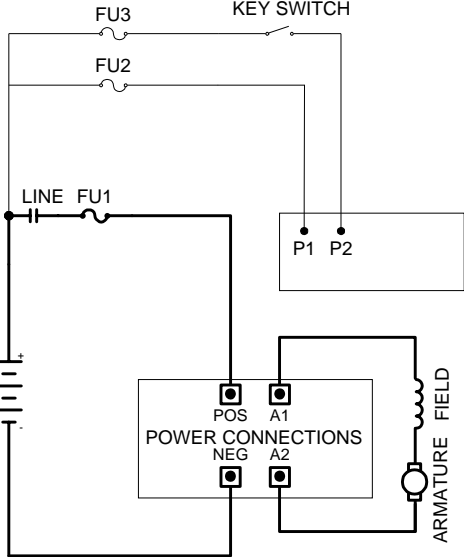
| PUMP STATUS CODE | DESCRIPTION OF STATUS | CAUSE OF STATUS INDICATION |
|------------------------------------|---|--|
| -128 | Armature current is too high during the lift mode. | Status code displayed when the current in the armature circuit is sustained above 300A for 70 sec. |
| MEMORY RECALL YES | CORRECTIVE ACTIONS | TROUBLE-SHOOTING DIAGRAM |
| Circuits valid for Pump Controller | <p>SYMPTOM Control will not operate.</p> <p>POSSIBLE CAUSE Continued operation of vehicle in high motor current condition.</p> <ul style="list-style-type: none"> Operate vehicle at lower motor current condition for 70 seconds. |  |

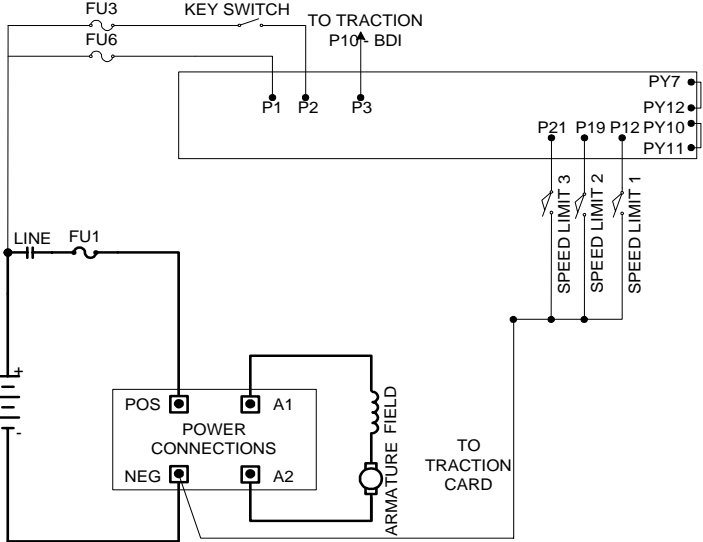
| PUMP STATUS CODE | DESCRIPTION OF STATUS | CAUSE OF STATUS INDICATION |
|------------------------------------|---|--|
| -141 | Open thermal protector (TP1) or transistor is over temperature. | This status code is displayed when the voltage at the thermal protector is greater than 0.8 volts. |
| MEMORY RECALL NO * | CORRECTIVE ACTIONS | TROUBLE-SHOOTING DIAGRAM |
| Circuits valid for Pump Controller | <p>SYMPTOM Reduced or no power to pump motor in control range.</p> <p>POSSIBLE CAUSE Control is in thermal cut-back.</p> <ul style="list-style-type: none"> Allow control to cool, status code should disappear. <p>* First status code displayed immediately, additional status codes displayed in 20 hour intervals.</p> |  |

| PUMP STATUS CODE | DESCRIPTION OF STATUS | CAUSE OF STATUS INDICATION |
|------------------------------------|--|--|
| -142 | Pump Controller "motor current sensor" input is missing. | This status code is displayed when the voltage at the current sensor is greater than 0.1 volts with no current flowing in the motor circuit. |
| MEMORY RECALL NO | CORRECTIVE ACTIONS | TROUBLE-SHOOTING DIAGRAM |
| Circuits valid for Pump Controller | <p>SYMPTOM No power to pump motor in control range.</p> <p>POSSIBLE CAUSE Control is defective.</p> <ul style="list-style-type: none"> • Replace controller unit. | |

| PUMP STATUS CODE | DESCRIPTION OF STATUS | CAUSE OF STATUS INDICATION |
|------------------------------------|--|--|
| -143 | Pump Controller "motor current sensor" input is too low. | This status code is displayed when the voltage at the current sensor is greater than 0.1 volts with no current flowing in the motor circuit. |
| MEMORY RECALL NO | CORRECTIVE ACTIONS | TROUBLE-SHOOTING DIAGRAM |
| Circuits valid for Pump Controller | <p>SYMPTOM No power to pump motor in control range.</p> <p>POSSIBLE CAUSE Control is defective.</p> <ul style="list-style-type: none"> • Replace controller unit. | |

| PUMP STATUS CODE | DESCRIPTION OF STATUS | CAUSE OF STATUS INDICATION |
|------------------------------------|---|---|
| -144 | Power Transistor (Q1) did not turn off properly. | This status code is displayed when, during pump control operation, the transistor fails to turn off. This will result in a PMT condition. |
| MEMORY RECALL YES | CORRECTIVE ACTIONS | TROUBLE-SHOOTING DIAGRAM |
| Circuits valid for Pump Controller | <p>SYMPTOM With no pump contactor, control may run continuously.</p> <p>POSSIBLE CAUSE Control is defective.</p> <ul style="list-style-type: none"> • Replace controller unit. | |

| PUMP STATUS CODE | DESCRIPTION OF STATUS | CAUSE OF STATUS INDICATION |
|------------------------------------|---|--|
| -145 | Power Transistor (Q1) did not turn on properly. | This status code is displayed when during pump control operation, the transistor fails to turn on. |
| MEMORY RECALL YES | CORRECTIVE ACTIONS | TROUBLE-SHOOTING DIAGRAM |
| Circuits valid for Pump Controller | <p>SYMPTOM With no pump contactor, the control may run continuously.</p> <p>POSSIBLE CAUSE Control is defective.</p> <ul style="list-style-type: none"> • Replace controller unit. | |

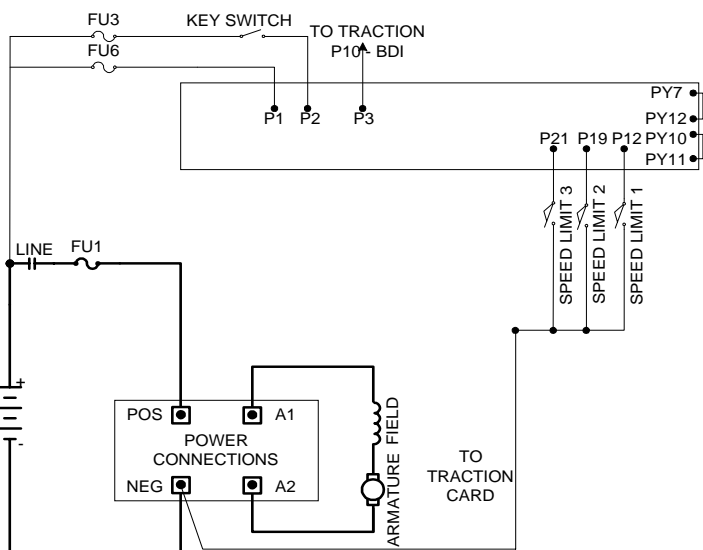
| PUMP STATUS CODE | DESCRIPTION OF STATUS | CAUSE OF STATUS INDICATION |
|------------------------------------|--|---|
| -146 | "Look Ahead" test for T2 volts less than 12% of battery volts. | This status code will be displayed when the voltage at T2 is less than 12% of battery volts. |
| MEMORY RECALL YES | CORRECTIVE ACTIONS | <p align="center"><u>TROUBLE-SHOOTING DIAGRAM</u></p>  |
| Circuits valid for Pump Controller | <p><u>SYMPTOM</u> Status code will be displayed during control operation and can only be re-set by opening and closing the key switch.</p> <p><u>POSSIBLE CAUSE</u> Check for short circuit from the motor armature to the frame of the vehicle.</p> <p>Control is defective.</p> <ul style="list-style-type: none"> • Replace controller unit. | |

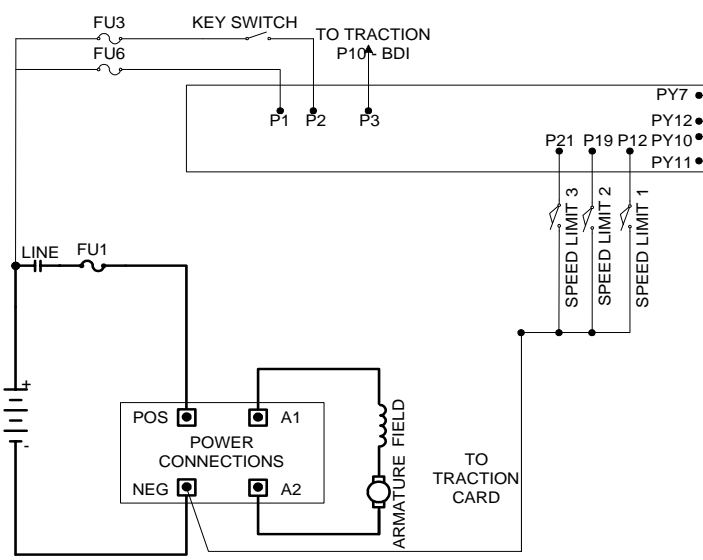
| PUMP STATUS CODE | DESCRIPTION OF STATUS | CAUSE OF STATUS INDICATION |
|------------------------------------|--|---|
| -150 | Capacitor volts are low after the line contactor closes. | This status code will be displayed when the capacitor voltage is less than 85% of the battery voltage in the run mode. |
| MEMORY RECALL YES | CORRECTIVE ACTIONS | <p align="center"><u>TROUBLE-SHOOTING DIAGRAM</u></p>  |
| Circuits valid for Pump Controller | <p><u>SYMPTOM</u> Pump control will not operate.</p> <p><u>POSSIBLE CAUSE</u> Defective line contactor.</p> <ul style="list-style-type: none"> • Check for open line contactor power tips. <p>Check for loose or open connections in cables from battery positive to control positive circuit.</p> <p>Defective power fuse.</p> <ul style="list-style-type: none"> • Check power fuse for open circuit. <p>No battery voltage at P1.</p> <ul style="list-style-type: none"> • Check for battery voltage at POS and P1. • Check for loose connection at P1. | |

| PUMP STATUS CODE | DESCRIPTION OF STATUS | CAUSE OF STATUS INDICATION |
|------------------------------------|---|---|
| -151 | Capacitor volts are low before the line contactor closes. (Internal card function during precharge) | This status code will be displayed during "key on" when the capacitor volts is less than 85% of battery volts at initial key switch on. |
| MEMORY RECALL NO | CORRECTIVE ACTIONS | <u>TROUBLE-SHOOTING DIAGRAM</u> |
| Circuits valid for Pump Controller | <p>SYMPTOM Pump control will not operate.</p> <p>POSSIBLE CAUSE Defective control fuse.</p> <ul style="list-style-type: none"> • Check control fuse for open circuit, replace fuse, if necessary. <p>Defective control.</p> <ul style="list-style-type: none"> • Replace controller unit. <p><i>Note: Repeated "charging/discharging" the capacitors during troubleshooting will cause status code 51. Also "do not" connect any loads to the load side of the line contactor.</i></p> | |

| PUMP STATUS CODE | DESCRIPTION OF STATUS | CAUSE OF STATUS INDICATION |
|------------------------------------|--|---|
| -157 | Controller "motor current sensor" input voltage polarity check. | This status code will be displayed when the voltage input to motor current sensor is of the wrong polarity. |
| MEMORY RECALL YES | CORRECTIVE ACTIONS | <u>TROUBLE-SHOOTING DIAGRAM</u> |
| Circuits valid for Pump Controller | <p>SYMPTOM Pump control will not operate.</p> <p>POSSIBLE CAUSE Control is defective.</p> <ul style="list-style-type: none"> • Replace controller unit. | |

| PUMP STATUS CODE | DESCRIPTION OF STATUS | CAUSE OF STATUS INDICATION |
|------------------------------------|---|--|
| -180 | Voltage at capacitor (1C) is less than 14 volts. | This status code will be displayed when the voltage at P1 is less than 14 volts. This occurs typically in the run mode of operation. |
| MEMORY RECALL YES | TROUBLE-SHOOTING DIAGRAM | |
| Circuits valid for Pump Controller | <p>SYMPTOM Pump control will not operate.</p> <p>POSSIBLE CAUSE (Line contactor controlled by traction control). Line Contactor opened up during run.</p> <ul style="list-style-type: none"> • Check connection from P17 to Line coil (-) for loose connection. • Check connection from battery (+) to Line coil (+) for loose connection. • Check power connection from battery (+) to contactor L. • Check for blown fuse at pump control. • Check for dirty contactor tips. | |

| PUMP STATUS CODE | DESCRIPTION OF STATUS | CAUSE OF STATUS INDICATION |
|------------------------------------|--|---|
| -181 | Battery voltage is less than 14 volts. | This status code will be displayed when the battery voltage measured at P1 is less than 14 volts. |
| MEMORY RECALL YES | TROUBLE-SHOOTING DIAGRAM | |
| Circuits valid for Pump Controller | <p>SYMPTOM Pump control will not operate.</p> <p>POSSIBLE CAUSE</p> <ul style="list-style-type: none"> • Defective control fuse. <p>Check control fuse for open circuit, replace fuse, if necessary.</p> <ul style="list-style-type: none"> • Check connection from control fuse to pump P1 for loose connections. | |

Section 5. TRUCK MANAGEMENT MODULE (TMM)

Section 5.1 General Features

The Truck Management Module is a multi-functional accessory card (IC3645TMM7A), or an integral function of the SR Pump control when used with the IT Family of Traction controls. The Module provides the OEM with the ability to initiate status codes or operator warning codes to be displayed on the Dash Display whenever a normally open switch or sensor wire provides a signal to the Module.

The TMM Module can be used to display a separate status code indicating an over temperature of traction motors, hydraulic motors, or any other device or system that can activate a switch that closes.

It can also be used as a Brush Wear Indicator (BWI). The Brush Wear Indicator is designed to detect a "worn-out brush" and display a fault code on the Dash Display to warn maintenance personnel that the motor brushes need to be replaced before they wear to the point of causing destructive damage to the motor commutator surface. The BWI function is compatible with any sensor that short circuits to the motor armature to signal limits of brush wear.

Note: Motor armature must be in the positive side of the battery circuit.

Section 5.2 Operation

The Module utilizes 9 OEM input points and 3 output points that connect to the "Y" plug on the traction logic card. **Due to the low level signal value of this output, shielded wire should always be used to insure proper operation.** The input to the Module is either a switch or sensor wire closure to battery negative or positive. The following table outlines the status code displayed for each input, when that point is closed to battery negative or positive, as indicated.

| TMM7A Card Terminal | Pump Control Terminal | Status Code | Connect To |
|---------------------|-----------------------|-------------|------------|
| TB1 | P16 | 90 * | Neg |
| TB3 | P11 | 91 | Neg |
| TB4 | P15 | 92 | Neg |
| TB5 | P3 | 93 * | Pos |
| TB6 | P4 | 93 * | Pos |
| TB8 | P5 | 94 | Pos |
| TB10 | P6 | 94 | Pos |
| TB11 | P8 | 95 | Pos |
| TB12 | P9 | 95 | Pos |

* Status codes 90 and 93 can also be programmed with the Handset to reduce the speed of the truck from 100 to 0 percent-on-time.

IMPORTANT NOTE: Status Codes 93, 94 and 95 are only checked when a neutral signal is present (i.e., open start switch or open F/R switch). The status code is displayed and the speed limit enabled when the control is returned to the run mode. Do not use status code 93 speed limit for applications requiring immediate speed limit on switch closure.

Typical wiring diagrams and outline drawings for the TMM7A accessory card and SR family of Pump TMM functions are shown in Sections 5.4 and 5.5.

Section 5.3 Installation

WARNING: Before any adjustments, servicing or act requiring physical contact with working components, jack drive wheels off the floor, disconnect the battery and discharge the capacitors in the traction and pump controls, as explained in Section 4.4.

The TMM7A accessory card should be mounted to a flat surface (in any plane) in an area protected from water, oil and battery acid. Mounting dimensions are shown in Section 5.5. Two (0.187 inch, 4.75mm) mounting holes are provided.

Section 5.4 Connection Diagrams

Section 5.4.1 TMM7A Card Connections

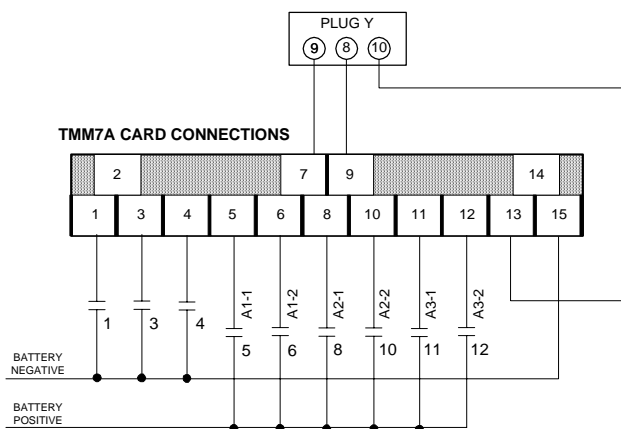

Section 5.4.2 Typical Brush Wear Sensor Connections

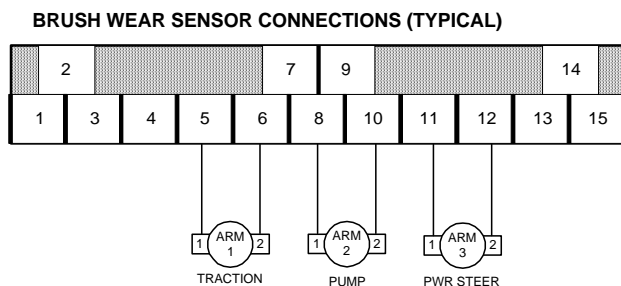

Section 5.4.3 TMM Pump Control Connections

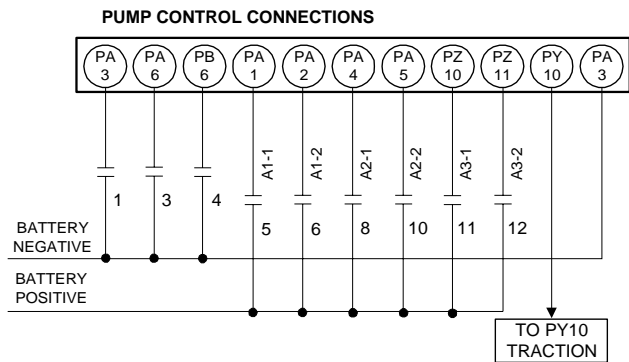

Section 5.5 TMM7A Outline Drawings

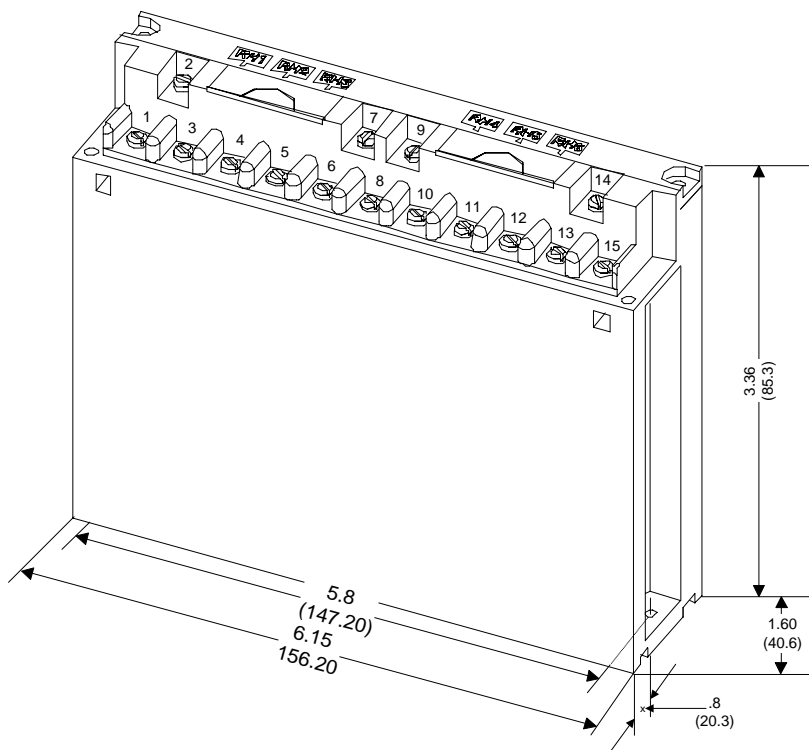

Section 6. SX and IT/IP FAMILY GE HANDSET INSTRUCTIONS

Section 6.1 General Features

The GE Handset is a multi-functional tool to be used with the LX, ZX, SX and IT/IP Series GE solid-state controls. The Handset consists of a Light Emitting Diode (LED) display and a keyboard for data entry.

Note: The Handset is the same for all GE controls, however, the cable will change between some control types.

Section 6.2 Purpose / Setup Functions

The purpose of the Handset is to allow authorized personnel to perform the following functions of the SX and IT/IP family of Controls:

- Monitor existing system fault codes
- Monitor intermittent random fault codes
- Monitor battery state of charge on systems with BDI
- Monitor hourmeter reading
- Monitor or adjust the following control functions:
 - ◆ Creep speed
 - ◆ Armature Controlled Acceleration and 1A Time
 - ◆ Regenerative Braking Current Limit and Disable
 - ◆ Armature and Field Current Limit
 - ◆ Plugging Distance (Current)
 - ◆ Pedal Position Plug Range or Disable
 - ◆ 1A Drop Out Current or Disable
 - ◆ Speed Limit Points
 - ◆ Truck Management Fault Speed Limit
 - ◆ Internal Resistance Compensation for Battery State of Charge Indication
 - ◆ Battery Voltage (36/48 volts is auto ranging)
 - ◆ Selection of Card Operation Type.

Warning: Before connecting or disconnecting the Handset tool, turn off the key switch, unplug the battery and jack up the drive wheels of the vehicle.

At the transistor control traction card, unplug the "Y plug" if the dash display is in use, and plug in the Handset to the plug location "Y" on the control card. After installing the Handset tool, plug the battery in and turn the key switch on. The following is the start-up display sequence that will occur:

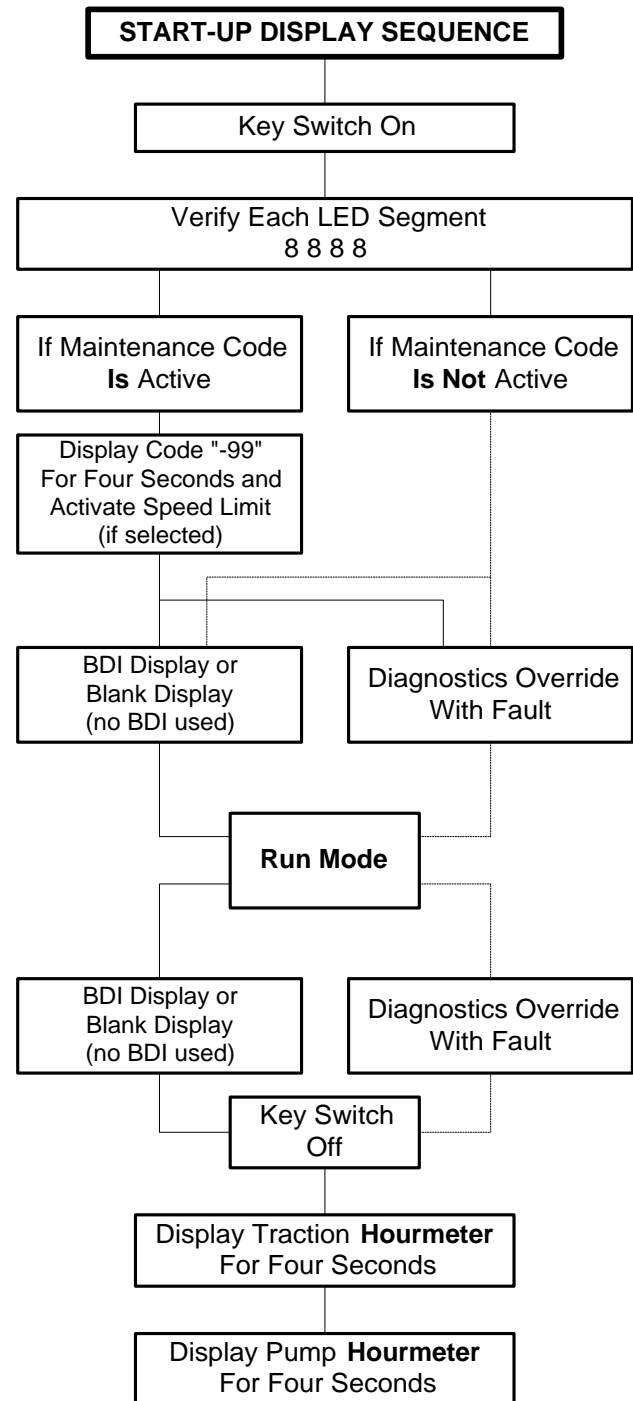

NOTE: The vehicle can be operated with the Handset connected, however, the adjustment knob must be set fully clockwise to insure the control operates at top speed.

Warning: Before making any adjustments to the control, you must consult the operating and maintenance instructions supplied by the vehicle manufacturer. Failure to follow proper set up instructions could result in mis-operation or damage to the control system.

Section 6.3 Set-up Function Procedures

With the Handset connected, hold down the **CONT** key and turn on the key switch. This will place you in the set-up mode, ready to monitor or adjust control function settings.

NOTE: The term "Push" means to depress key for approximately one second.

Section 6.3.1 Setup Mode

SET-UP MODE

| ACTION | DISPLAY SHOWS | REMARKS |
|-----------------------------------|---------------|--|
| Hold Down CONT And Turn On Key | 8 8 8 8 | Segment Check Displayed |
| Push Function Number | U 0 0 5 | Selected Function No. Is Displayed |
| After One Second Time Delay | 0 8 5 | Stored Value For The Function Is Displayed |
| Push CONT | 0 8 5 | Display Value Will Blink |
| Change Value With Adjustment Knob | 1 2 5 | Value Changes While Blinking |
| Push STORE | 1 2 5 | New Value Stored And Blinking Stops |
| Push ESC | 8 8 8 8 | Segment Check Displayed |

At this point, another function can be monitored/changed by pushing another function number, or the vehicle can be placed in the run mode by holding the **ESC** key down for one second or longer. The display will return to either the diagnostics mode, the BDI display, or a blank display (if BDI is not used and there are no fault codes). The vehicle can now be operated with the Handset connected, or the Handset can be disconnected before operation.

NOTE: You can return to the segment check mode at any time, by holding down the **ESC** key until 8888 appears in the display.

Section 6.3.2 Status Code Scrolling

The SX and IT families of controllers furnish a function register that contains the last 16 "stored status codes" that shut down vehicle operation (a PMT type fault that is reset by cycling the key switch) and the battery state of charge reading at the time the fault occurred. The first of the 16

status codes will be overwritten each time a new status code occurs. This stored status code register can be cleared from memory by using the Handset.

ACCESSING STORED STATUS CODES WITH GE HANDSET

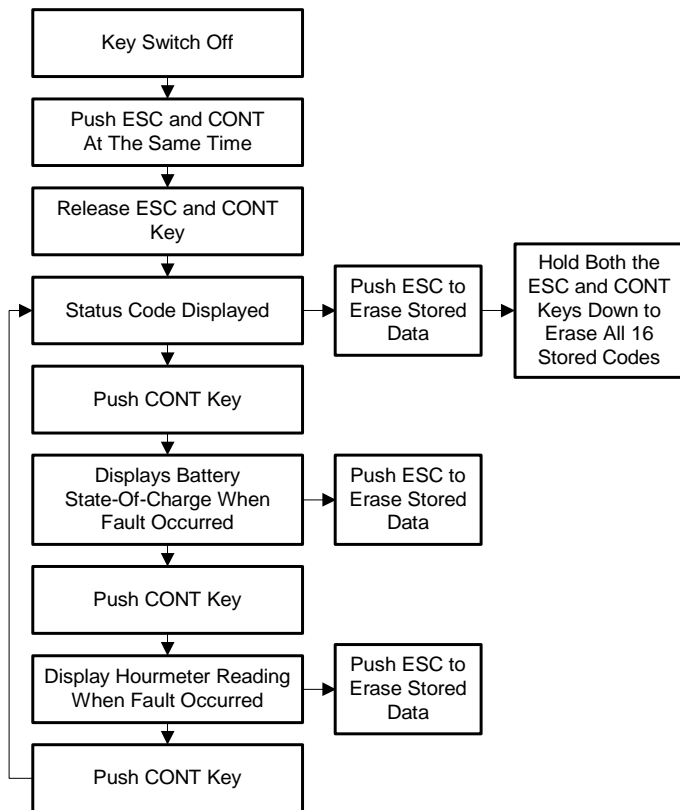

Section 6.3.3 IT/IP Family Handset, Plug Connections and Outline Drawing

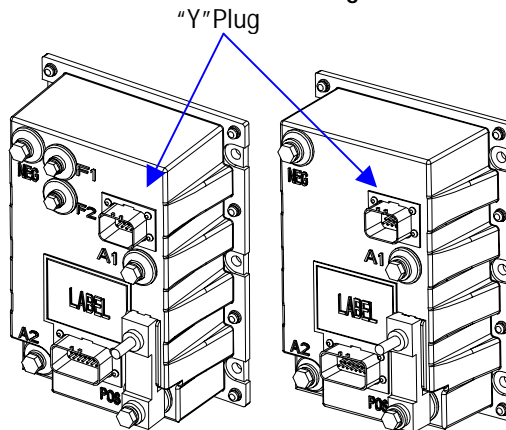

Handset Cable Part Number - 171B3990G4

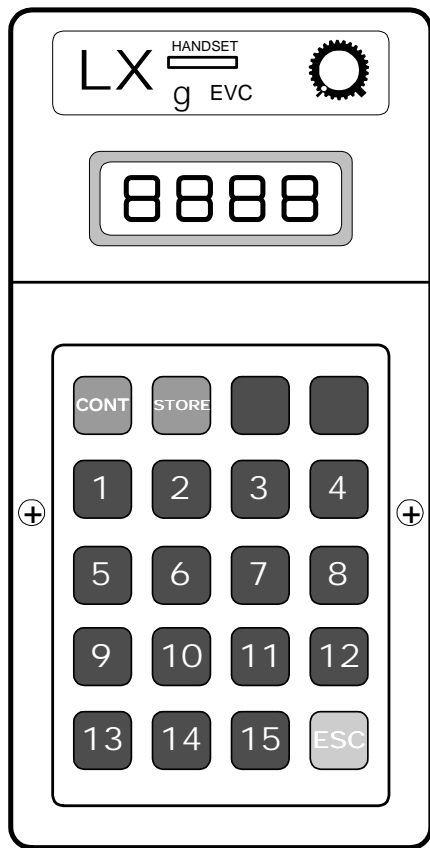

Section 6.4 Setup Functions for Traction Controller

FUNCTION 1 MOTOR VOLTS TO ENABLE AUTO REGEN (Push 1)

This function allows for the adjustment of motor volts to enable AutoRegen.

For a setting value of less than 25 (corresponding to a soft release of auto regen and normal regen), the motor voltage to enable regen is calculated by multiplying the value of the setting by 0.375. For example, a setting of 16 will be multiplied by 0.375 to enable regen at 6 motor volts.

$$V_m = VAL(\text{setting}) \times .375$$

For a setting value of greater than 25, the motor voltage to enable auto regen is calculated by subtracting 25 from the setting value and multiplying that number by 0.375. For example, a setting of 33, the motor volts necessary to enable auto regen is $(33 - 25) \times 0.375$, or 3 volts.

FUNCTION 2 CREEP SPEED (Push 2)

This function allows for the adjustment of the creep speed of the vehicle. Creep speed can be adjusted when an accelerator input voltage between 3.9 and 3.3 volts or an

accelerator ohm input between 6.0K and 4.0K ohms is provided.

| | |
|------------|----------------------------|
| Range | 2% to 15% on-time |
| Set | 0 to 255 |
| Resolution | 0.05% per set unit |
| Example | Setting of 20 = 3% on-time |

Important Note: This function is used to optimize motor and control performance, and this setting will be determined by GE and OEM engineers at the time of vehicle development. This setting must not be changed by field personnel without the permission of the OEM.

FUNCTION 3 ARMATURE CONTROLLED ACCELERATION (Push 3)

This function allows for the adjustment of the rate of time it takes for the control to accelerate to 100% applied battery voltage to the motor on hard acceleration.

| | |
|------------|-----------------------------|
| Range | 0.025 to 6.3 seconds |
| Set | 0 to 255 |
| Resolution | 0.025 seconds per set unit |
| Example: | Setting of 20 = 0.5 seconds |

FUNCTION 4 ARMATURE CURRENT LIMIT (Push 4)

This function allows for the adjustment of the armature current limit of the control. The rating of the control will determine the range of adjustment for this function. Please refer to the specification sheets and current limit curves for the control used in your vehicle.

| | |
|----------|--------------------------------------|
| Range | See control C/L curves |
| Set | 0 to 255 |
| Example: | 0 = min. current, 255 = max. current |

FUNCTION 5 PLUGGING DISTANCE (CURRENT) (Push 5)

This function allows for the adjustment of the plugging distance of the vehicle. The larger the current setting, the shorter the stopping distance.

| Min | Max | Set | Resolution Per Unit Value | Example If Set at 20 |
|-----|-----|----------|---------------------------|----------------------|
| 55 | 455 | 0 to 255 | 1.57 amps | 86.4 amps |

Warning: Plug settings must be made in accordance with control operating instructions. Too high of a setting could cause damage to the control system or traction motor.

**FUNCTION 6 FW RATIO
(Push 6)**

This function sets the ratio between armature and field current when operating below the Field Weakening Start point. The setting represents the quantity of field current changed for each 1 amp of armature current changed.

| Max Fld Ref | Set | Resolution Per Unit Value |
|-------------|---------|---------------------------|
| 40 | 0 to 10 | 0.029 amps |

The ratio value (VAL) is the set value divided by 10 and rounded to the whole number.

Example: Setting of 45 = 45/10 = 4.5 = 4 VAL

$$I_{FIELD} = VAL (I_{MOTOR} \times 0.029)$$

**FUNCTION 7 MIN FIELD CURRENT
(Push 7)**

This function allows the adjustment of the field weakening level in order to set the top speed of the motor.

| Min | Max | Set | Resolution Per Unit Value |
|-----|-----|-----------|---------------------------|
| 0 | 40 | 51 to 255 | 0.185 |

$$MIN I_F = (VAL-51) \times 0.185$$

Important Note: This function is used to optimize motor and control performance, and this setting will be determined by GE and OEM engineers at the time of vehicle development. This setting must not be changed by field personnel without the permission of the OEM.

**FUNCTION 8 MAX FIELD CURRENT
(Push 8)**

This function allows for the adjustment of the maximum field current in order to obtain the maximum torque of the motor.

| Min | Max | Set | Resolution Per Unit Value |
|-----|-----|-----------|---------------------------|
| 0 | 40 | 51 to 255 | 0.185 |

$$MAX I_F = (VAL-51) \times 0.185$$

Important Note: This function is used to optimize motor and control performance, and this setting will be determined by GE and OEM engineers at the time of vehicle development. This setting must not be changed by field personnel without the permission of the OEM.

**FUNCTION 9 REGEN BRAKING C/L
(Push 9)**

This function allows for the adjustment of the Regen braking current limit. High current correlates to shorter stopping distance.

| Min | Max | Set | Resolution Per unit value | Example If set at 20 |
|-----|------|----------|---------------------------|----------------------|
| 52A | 468A | 0 to 255 | 1.63 amps | 84.6 amps |

$$REGEN BRAKE I_A = (VAL \times 1.63) + 52$$

**FUNCTION 10 FIELD CURRENT FOR REGEN
(Push 10)**

This function allows for the adjustment of the field current to be used during the regen braking mode.

| Min | Max | Set | Resolution Per unit value | Example If set at 71 |
|-----|-----|-----------|---------------------------|----------------------|
| 0 | 40 | 51 to 255 | 0.185 amps | 3.7 amps |

$$I_F = (VAL-51) \times 0.185$$

Important Note: This function is used to optimize motor and control performance and this setting will be determined by GE and OEM engineers at the time of vehicle development. This setting must not be changed by field personnel without the permission of the OEM.

**FUNCTION 11 TURN SPEED LIMIT
(Push 11)**

This function allows for the adjustment of the speed limit (maximum battery volts to the motor) when the SL1 signal is calculated from the turn angle potentiometer by the control card.

| | |
|------------|--|
| Range | 100% to 0% battery volts |
| Set | 51 to 180 |
| Resolution | 0.78% per set unit |
| Example | Setting of 71 = 84.4% of battery volts |

Note: To disable speed limit, and assure no 1A hold off, set this function to a value of zero.

**FUNCTION 12 MAX ARMATURE PERCENT ON
(Push 12)**

Same as function 11, this function allows for the adjustment of the motor speed limit (maximum battery volts to the motor). The dash display mode selection enables the speed limit as well as setting the level of speed limit.

**FUNCTION 13 SPEED LIMIT 3
(Push 13)**

The SL3 set speed limit is activated by the Truck Management Module 90, 91 and 92. See Section 5 for Truck Management Module details.

**FUNCTION 14 INTERNAL RESISTANCE
COMPENSATION
(Push 14)**

This function is used when the Battery Discharge Indicator is present. Adjustment of this function will improve the accuracy of the BDI. In order to determine this setting the voltage drop of the battery under load must first be calculated by the following method:

1. Load the traction motor to 100 amps at 100% on-time of the control and record the open circuit voltage (V_0) at the control panel positive and negative power terminal.
2. Load the traction motor to 200 amps at 100% on time of the control and record the voltage (V_L) at the control panel positive and negative power terminal.
3. Calculate voltage drop (V_{Drop}) as follows:
 $V_{Drop} = V_0 - V_L$
4. Use the table below to determine the appropriate setting using the calculated V_{Drop} as a reference.

**INTERNAL RESISTANCE COMPENSATION
TABLE**

| Setting | V_{Drop} | Setting | V_{Drop} |
|---------|------------|---------|------------|
| 2 | 11.44 | 17 | 01.34 |
| 3 | 07.60 | 18 | 01.27 |
| 4 | 05.72 | 19 | 01.20 |
| 5 | 04.57 | 20 | 01.14 |
| 6 | 03.81 | 21 | 01.09 |
| 7 | 03.27 | 22 | 01.04 |
| 8 | 02.86 | 23 | 00.99 |
| 9 | 02.54 | 24 | 00.95 |
| 10 | 02.28 | 25 | 00.91 |
| 11 | 02.08 | 26 | 00.88 |
| 12 | 01.90 | 27 | 00.85 |
| 13 | 01.76 | 28 | 00.82 |
| 14 | 01.63 | 29 | 00.79 |
| 15 | 01.52 | 30 | 00.76 |
| 16 | 01.43 | 31 | 00.74 |

**FUNCTION 15 BATTERY VOLTS
(Push I5)**

This function allows for the adjustment of voltage range for controls equipped with the Battery Discharge Indication function. In order for the BDI to operate properly, the setting as shown in the table must be entered:

Battery volts
24 volts
36 volts
48 volts
72 volts
80 volts
36/48 volts
No BDI

Set units
Between 0 and 31
Between 32 and 44
Between 45 and 69
Between 70 and 80
Between 81 and 183
Between 184 and 250
Between 251 and 255

The following functions have function numbers larger than the numbers on the Handset keyboard. To access these functions, push the CONT key and the number shown in the following instructions at the same time.

**FUNCTION 16 STALL TRIP POINT WITH % ON-TIME
(Push CONT 1)**

This function allows for the adjustment of control percent on time for the stall motor trip point

Control % On time = $163 - (\text{Set Point Val}) \cdot .892$

- If 163 or greater, then "0.0" % on time
- If 51 or less, then "100."% on-time

**FUNCTION 17 CARD TYPE SELECTION
(Push CONT 2)**

This function allows for the selection of the card type used for your vehicle's application. The table below shows the setting to select card application type, depending on which control card is used. *Note that the right (slave) control for a dual motor proportioning system will be set differently than the left (master) control.*

| FUNCTIONS | REGEN |
|---------------------------|------------|
| Std C/L Auto Plug | 55 to 59 |
| Std C/L Auto Plug (Right) | 119 to 123 |

Settings for these functions should be made within the ranges indicated above.

Warning: These settings must be changed by authorized personnel only, following instructions supplied by the vehicle manufacturer. Card type selection must be made within the capabilities of the control panel used and the supporting electro mechanical devices. Failure to comply with proper application standards could result in mis-operation or damage to the control and/or motors.

**FUNCTION 18 STEER PUMP TIME DELAY
(Push CONT 3)**

This function allows for the selection of steer pump contactor pick up input, either seat switch or directional

switch closing, and adjustment of the time delay for the contactor drop out.

- **Pick up steer pump contactor on seat switch closure and time delay drop out of steer pump contactor on seat switch opening:**

Range 1.5 to 65 seconds
Setting Between 0 and 128
Resolution 0.5 seconds per set unit

Example: Setting of 20 = (20 x 0.5) + 1.5 = 11.5 seconds

- **Pick up steer pump contactor on directional switch closure and time delay drop out of steer pump contactor on directional switch opening:**

Range 0.5 to 63 seconds
Setting Between 129 and 255
Resolution 0.5 seconds per set unit

Example: Setting of 149 = ((149-129) x 0.5) + 1.5 = 11.5 seconds

Note: Contactor drop out will be 1.5 seconds after the seat switch opens.

FUNCTION 19 MAINTENANCE CODE TENS AND UNITS HOURS SET (Push CONT 4)

This function allows for the adjustment of the tens and units hours of the maintenance code activation time.

Range 0 to 99
Set 0 to 99
Example 9999 Hours

FUNCTION 20 MAINTENANCE CODE THOUSANDS AND HUNDREDS HOURS SET (Push CONT 5)

This function allows for the adjustment of the thousands and hundreds hours of the maintenance code activation time.

Range 0 to 240
Set 0 to 240
Example 9999 Hours

FUNCTION 21 AUTO REGEN BRAKING C/L (Push CONT 6)

This function allows for the adjustment of the Regen braking current limit. High current value correlates to shorter stopping distance.

Setting greater than 143 disables this function.

$$\text{AUTO REGEN C/L AMPS} = \text{REGEN C/L VAL} - \left[\left(\frac{\text{FNT 21-51}}{\text{VAL}} \right) 6.50 \right]$$

FUNCTION 24 FIELD WEAKENING START (Push CONT 9)

This function allows for setting the armature current at which minimum field current will be achieved .

Range 0 to 414 Amps
Setting 0 to 255
Resolution 1.625 per set unit
 $I_{\text{MOTOR FWS}} = \text{VAL} \times 1.625$

Example: Setting of 20 = 32.5 amps

FUNCTION 25 MONITOR (Push CONT 10)

This function allows the monitoring of certain control functions by looking directly at the RAM of the microprocessor. Because absolute memory locations need to be known, this function should not be used without detailed instructions from the GE application engineer.

This function should only be adjusted by the vehicle OEM. To ensure optimum operation of the control, this function must be left with zero stored in this register.

FUNCTION 26 BASE RATIO (Push CONT 11)

This function sets the ratio between armature and field current when operating below the maximum field current and above the Field Weakening Start point. The setting represents the quantity of field current changed for each 1 amp of armature current changed.

| Max fld Ref | Set | Resolution Per Unit Value |
|-------------|---------|---------------------------|
| 40 | 0 to 10 | 0.029 amps |

The ratio value (VAL) is the set value divided by 10 and rounded to the whole number.

Example: Setting of 45 = 45/10 = 4.5 = 4 VAL

$$I_{\text{FIELD}} = \text{VAL} (I_{\text{MOTOR}} \times 0.029)$$

**FUNCTION 28 STORED STATUS CODE COUNT POINTER
 (Push CONT 13)**

This register contains the location of the last stored status code recorded of the 16 stored status codes. These stored status codes have caused a PMT controller shutdown and/or disruption of normal vehicle operation.

To determine which stored status code was the last one recorded, read the number stored in Function 28. Using the **Memory Map** for your logic card, match the "**stored status code pointer number**" [the number shown in (*bold italics*) in the HS (Handset) number column] on the memory map, with the number obtained from Function 28. This will be the last stored status code recorded.

Note: When scrolling through the stored status code register, the register always starts at status code 1 and scrolls to status code 16. Instructions for scrolling the register are in section 6.3.2 of this instruction booklet.

The following functions have function numbers larger than the numbers on the Handset keyboard. To access these functions. Push the CONT key and the number shown in the following instructions at the same time. THE SEAT SWITCH MUST BE CLOSED.

**FUNCTION 48 MODE 1 (TURTLE) - ARMATURE
 CONTROLLED ACCELERATION
 (Push CONT 1)**

This function allows for the adjustment of the rate of time it takes for the control to accelerate to 100% applied battery voltage to the motor on hard acceleration.

| | |
|------------|-----------------------------|
| Range | 0.025 to 6.3 seconds |
| Set | 0 to 255 |
| Resolution | 0.025 seconds per set unit |
| Example: | Setting of 20 = 0.5 seconds |

This C/A takes effect when the Mode 1 settings are called for by the interactive Dash Display.

**FUNCTION 49 MODE 1 FIELD WEAKENING START
 (Push CONT 2)**

This function allows for setting the armature current at which minimum field current will be achieved.

| | |
|------------|--------------------|
| Range | 0 to 414 Amps |
| Setting | 0 to 255 |
| Resolution | 1.625 per set unit |

Example: Setting of 20 = 32.5 amps

$$I_M \text{ FWS} = \text{VAL} \times 1.625$$

This FIELD WEAKENING START takes effect when the Mode 1 settings are called for by the interactive Dash Display.

**FUNCTION 50 MODE 1 FW RATIO
 (Push CONT 3)**

This function sets the ratio between armature and field current when transitioning from minimum field to maximum field current. The setting represents the quantity of field current changed for each 1 amp of armature current changed.

| Max Fld Ref | Set | Resolution Per Unit Value |
|-------------|---------|---------------------------|
| 40 | 0 to 10 | 0.029 amps |

The ratio value (VAL) is the set value divided by 10 and rounded to the lowest whole number.

Example : Setting of 45 = 45/10 = 4.5 = 4 VAL.

$$I_{\text{FIELD}} = \text{VAL} (I_{\text{MOTOR}} \times .029)$$

This FW RATIO takes effect when the Mode 1 settings are called for by the interactive Dash Display.

**FUNCTION 51 MODE 1 MAX ARMATURE % ON
 (Push CONT 4)**

This function allows for the adjustment of the speed limit (maximum battery volts to the motor) when the SL1 limit switch input signal is received by the control card. The SL1 limit switch is a normally closed switch connected to battery negative; the switch opening enables speed limit.

| | |
|------------|--------------------------------------|
| Range | 100% to 0% battery volts |
| Set | 51 to 180 |
| Resolution | 0.78 % per set unit |
| Example | Setting of 71 = 84.4 % battery volts |

This MAX ARMATURE % ON takes effect when the Mode 1 settings are called for by the interactive Dash Display.

**FUNCTION 52 MODE 2 ARMATURE CONTROLLED
 ACCELERATION
 (Push CONT 5)**

Same as Function 48.

This C/A takes effect when the Mode 2 settings are called for by the interactive Dash Display.

**FUNCTION 53 MODE 2 FIELD WEAKENING START
 (Push CONT 6)**

Same as Function 49.

This FIELD WEAKENING START takes effect when the Mode 2 settings are called for by the interactive Dash Display.

**FUNCTION 54 MODE 1 FW RATIO
 (Push CONT 7)**

Same as Function 50.

This FW RATIO takes effect when the Mode 2 settings are called for by the interactive Dash Display.

**FUNCTION 55 MODE 2 MAX ARMATURE % ON
 (Push CONT 8)**

Same as Function 51.

This MAX ARMATURE % ON takes effect when the Mode 2 settings are called for by the interactive Dash Display.

**FUNCTION 56 MODE 3 ARMATURE
 CONTROLLED ACCELERATION
 (Push CONT 9)**

Same as Function 48.

This C/A takes effect when the Mode 3 settings are called for by the interactive Dash Display.

**FUNCTION 57 MODE 3 FIELD WEAKENING START
 (Push CONT 10)**

Same as Function 49.

This FIELD WEAKENING START takes effect when the Mode 3 settings are called for by the interactive Dash Display.

**FUNCTION 58 MODE 3 FW RATIO
 (Push CONT 11)**

Same as Function 50.

This F/W RATIO takes effect when the Mode 3 settings are called for by the interactive Dash Display.

**FUNCTION 59 MODE 3 MAX ARMATURE % ON
 (Push CONT 12)**

Same as Function 51.

This MAX ARMATURE % ON takes effect when the Mode 3 settings are called for by the interactive Dash Display.

**FUNCTION 60 MODE 4 ARMATURE
 CONTROLLED ACCELERATION
 (Push CONT 13)**

Same as Function 48.

This C/A takes effect when the Mode 4 settings are called for by the interactive Dash Display.

**FUNCTION 61 MODE 4 FIELD WEAKENING START
 (Push CONT 14)**

Same as Function 49.

This FIELD WEAKENING START takes effect when the Mode 4 settings are called for by the interactive Dash Display.

**FUNCTION 62 MODE 4 FW RATIO
 (Push CONT 15)**

Same as Function 50.

This F/W RATIO takes effect when the Mode 4 settings are called for by the interactive Dash Display.

**FUNCTION 63 MODE 4 MAX ARMATURE % ON
 (Push CONT ESC)**

Same as Function 51.

This MAX ARMATURE % ON takes effect when the Mode 4 settings are called for by the interactive Dash Display.

Section 6.5 Summary of Current Limit Adjustments

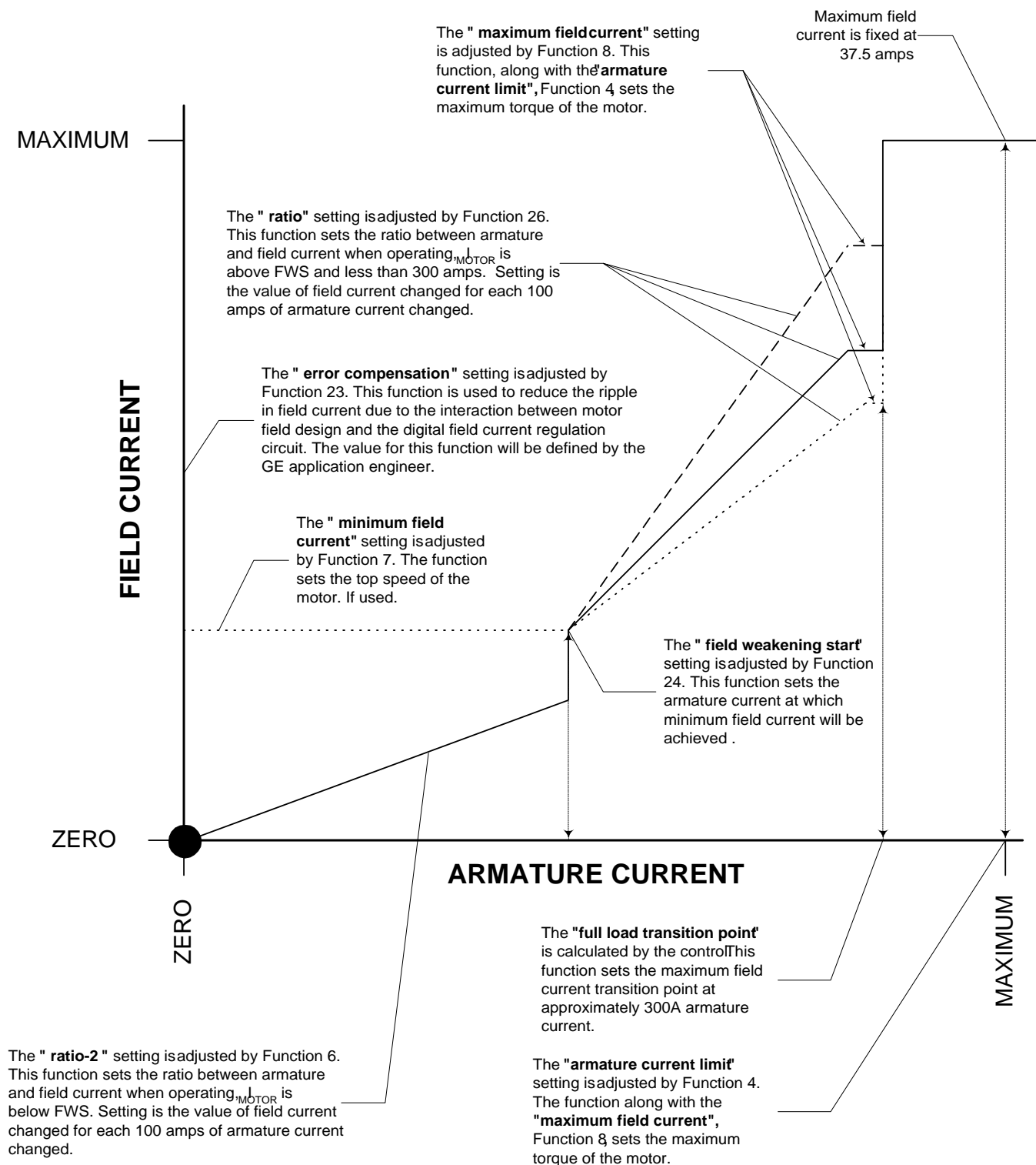

Section 6.6 Setup Functions for Hydraulic Pump Control

FUNCTION 1: NOT APPLICABLE

This function is not applicable to this type of control and should not be adjusted.

**FUNCTION 2: INTERNAL RESISTANCE
COMPENSATION START
(Push 2)**

This function allows for the adjustment of the current level at which the internal resistance compensation feature (Function 16) will take effect.

Range 0 to 1325 amps
Setting 52 to 255
Resolution 6.5 amps per set unit

Example: Setting of 72 = $(72-52) \times 6.5 = 130$ amps

**FUNCTION 3: CONTROLLED ACCELERATION
(Push 3)**

This function allows for the adjustment of the rate of time it takes for the control to accelerate to 96% applied battery voltage to the motor on hard acceleration.

Range 0.1 to 5.5 seconds
Setting 0 to 255
Resolution 0.021 seconds per set unit

Example: Setting of 20 = 0.52 seconds C/A

**FUNCTION 4: CURRENT LIMIT
(Push 4)**

This function allows for the adjustment of the current limit of the control. The rating of the control will determine the range of adjustment for this function. Please refer to the OEM operating instructions for the control used in your vehicle.

Range See OEM control C/L curves
Setting 0 to 255

Example: 0 = min. current, 255 = max. current

**FUNCTION 7: INTERNAL RESISTANCE
COMPENSATION RATE
(Push 7)**

This function allows for the adjustment of the rate of time it takes for the control to add the internal resistance compensation voltage that is applied to the motor. This function will add 0.375 volts to the motor at the rate of time

adjusted until the total IR compensation voltage has been added.

Range 0.0015 to 0.383 seconds
Setting 0 to 255
Resolution 0.0015 seconds per set unit

Example: Setting of 20 = 0.032 seconds
For example, if you had selected 2.08 volts from Function 16 to be added to the motor, it would take 0.18 seconds to add a total of 2.08 volts. $(2.08/0.375)=0.032$

**FUNCTION 11: SPEED LIMIT 1 (SL1)
(Push 11)**

This function allows for the adjustment of the speed limit (maximum battery volts to the motor) when the SL1 limit switch input signal is received by the control card. SL1 limit switch is a normally open switch connected to battery negative, the switch closing enables speed limit.

Range 0% to 100% battery volts
Setting 0 to 255
Resolution 0.375 volts per set unit

Example: Setting of 50=18.75 volts

**FUNCTION 12: SPEED LIMIT 2 (SL2)
(Push 12)**

Same as Function 11 except using SL2 limit switch for input.

**FUNCTION 13: SPEED LIMIT 3 (SL3)
(Push 13)**

Same as Function 11 except using SL3 limit switch for input.

FUNCTION 14: NOT APPLICABLE

This function is not applicable to this type of control and should not be adjusted.

Note: The following functions have function numbers larger than the numbers on the Handset keyboard. To access these functions, push the CONT key and the number shown in the following instructions at the same time. THE KEY SWITCH MUST BE CLOSED.

**FUNCTION 16: SPEED / TORQUE COMPENSATION
(Push CONT 1)**

This function is used to stabilize pump speed at heavy loads. The voltage selected will be added to the motor at each 100 amp increment starting at the value set in Function 2. The voltage compensation selected will be added in increments of 0.375 volts until the entire voltage is

added. For example, a setting of 2 will be added in 30 steps of 0.375 volts each whereas, a setting of 4 will be added in 15 steps of 0.375 volts each.

SPEED / TORQUE
COMPENSATION TABLE

| SETTING | VOLTAGE DROP | SETTING | VOLTAGE DROP |
|---------|--------------|---------|--------------|
| 2 | 11.44 | 17 | 1.34 |
| 3 | 7.60 | 18 | 1.27 |
| 4 | 5.72 | 19 | 1.20 |
| 5 | 4.57 | 20 | 1.14 |
| 6 | 3.81 | 21 | 1.09 |
| 7 | 3.27 | 22 | 1.04 |
| 8 | 2.86 | 23 | 0.99 |
| 9 | 2.54 | 24 | 0.95 |
| 10 | 2.28 | 25 | 0.91 |
| 11 | 2.08 | 26 | 0.88 |
| 12 | 1.90 | 27 | 0.85 |
| 13 | 1.76 | 28 | 0.82 |
| 14 | 1.63 | 29 | 0.79 |
| 15 | 1.52 | 30 | 0.76 |
| 16 | 1.43 | 31 | 0.74 |

FUNCTION 17: CARD TYPE SELECTION
(Push CONT 2)

This function should be set in accordance with the control type in use in the vehicle:

| Function | Without Pump Ctr/PMT |
|----------------------|----------------------|
| High C/L BDI Lockout | 63 to 71 |

BDI Lockout means that the BDI signal from the traction control must be present in order for the pump control to operate. This control will stop operation when the battery state of charge reaches 10%.

Settings for these functions should be made in between the values shown.

Warning: *These setting must be changed by authorized personnel only, following instructions supplied by the manufacturer. Card type selection must be made within the capabilities of the TRANSISTOR control panel used and the supporting electro-mechanical devices. Failure to comply with proper application standards could result in mis-operation or damage to the control and/or motors.*

FUNCTION 28: FAULT COUNT POINTER
(Push CONT 13)

This register contains the location of the last stored status code recorded of the 16 stored status codes. These stored status codes have caused a PMT controller shutdown and/or disruption of normal vehicle operation.

To determine which stored status code was the last one recorded, read the number stored in Function 28. Using the **Memory Map** (See Section 8.1) for your logic card, match the "stored status code pointer number" (the number shown in ***bold italics***) in the HS (Handset) number column) on the memory map, with the number obtained from Function 28. This will be the last stored status code recorded.

Note: When scrolling the stored status code register, the register always starts at status code 1 and scrolls to status code 16. Instructions for scrolling the register are in Section 6.3.2 of this instruction booklet.

Note: *The following functions have function numbers larger than the numbers on the Handset keyboard. To access these functions, push the CONT key and the number shown in the following instructions at the same time. THE KEY SWITCH MUST BE OPEN.*

FUNCTION 48: MODE 1 - CONTROLLED ACCELERATION
(Push CONT 1)

This function allows for the adjustment of the rate of time it takes for the control to accelerate to 96% applied battery voltage to the motor on hard acceleration.

Range 0.1 to 22.0 seconds
Setting 0 to 255
Resolution 0.084 seconds per set unit

Example: Setting of 20 = 1.8 seconds C/A

FUNCTION 49: MODE 1 - SPEED LIMIT 2 (SL2)
(Push CONT 2)

This function allows for the adjustment of the speed limit (maximum battery volts to the motor) when the SL2 limit switch input signal is received by the control card. SL2 limit switch is a normally open switch connected to battery negative, the switch closing enables speed limit.

Range 0% to 100% battery volts
Setting 0 to 255
Resolution 0.375 volts per set unit

Example: Setting of 50=18.75 volts

FUNCTION 50: MODE 1 - SPEED LIMIT 3 (SL3)
(Push CONT 3)

This function allows for the adjustment of the speed limit (maximum battery volts to the motor) when the SL3 limit switch input signal is received by the control card. SL3 limit switch is a normally open switch connected to battery negative, the switch closing enables speed limit.

Range 0% to 100% battery volts
Setting 0 to 255
Resolution 0.375 volts per set unit

Example: Setting of 50=18.75 volts

FUNCTION 52: MODE 2 - CONTROLLED ACCELERATION
(Push CONT 5)

Same as function 48.

FUNCTION 53: MODE 2 - SPEED LIMIT 2 (SL2)
(Push CONT 6)

Same as Function 49.

FUNCTION 54: MODE 2 - SPEED LIMIT 3 (SL3)
(Push CONT 7)

Same as Function 50.

FUNCTION 55: NOT APPLICABLE

This function is not applicable to this type of control and should not be adjusted.

FUNCTION 56: MODE 3 - CONTROLLED ACCELERATION
(Push CONT 9)

Same as function 48.

FUNCTION 57: MODE 3 - SPEED LIMIT 2 (SL2)
(Push CONT 10)

Same as Function 49.

FUNCTION 58: MODE 3 - SPEED LIMIT 3 (SL3)
(Push CONT 11)

Same as Function 50.

FUNCTION 59: NOT APPLICABLE

This function is not applicable to this type of control and should not be adjusted.

FUNCTION 60: MODE 4 - CONTROLLED ACCELERATION
(Push CONT 13)

Same as function 48.

FUNCTION 61: MODE 4 - SPEED LIMIT 2 (SL2)
(Push CONT 14)

Same as Function 49.

FUNCTION 62: MODE 4 - SPEED LIMIT 3 (SL3)
(Push CONT 15)

Same as Function 50.

Section 7. DASH DISPLAYS

Section 7.1 Application

The SX family Standard and Interactive Dash Displays allow the operator and maintenance personnel easy access to truck operation information and real-time system diagnostics of the controller, motor and various accessories. Hourmeter readings, battery discharge information, maintenance information and system status codes are clearly displayed during startup and running modes. Shielded cable connections are made to the Dash Display by means of five (5) 22-gage wires to the "Y" Plug of the traction and hydraulic pump controls.

Section 7.2 Standard Dash Displays

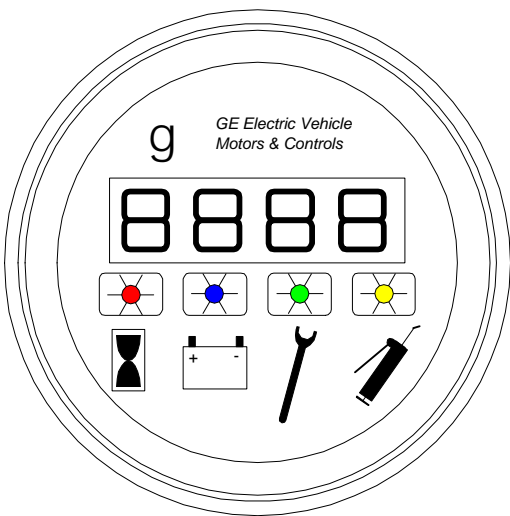

The GE Standard Dash Display is a four segment Light Emitting Diode (LED) instrument that displays the GE LX, ZX, and SX Status Codes, Hourmeter Readings, Battery Discharge Indication, and Maintenance Required Code. The four LED's above the symbols indicate the active readout mode.

Section 7.3 Interactive Custom Dash Displays



The Interactive Custom Dash Display allows the operator to select the best vehicle performance for changing factory (task) conditions. There are four (4) "operator interaction modes" that can be selected by depressing a push-button on the dash display.

From the Dash Display, the operator may select any of four pre-set interactive modes consisting of (4) Controlled Acceleration levels, (4) Field Weakening Pick Up levels and (4) Speed Limit levels.

These interactive modes are "pre-set" using the Handset (Functions 48 - 63) or a personal computer (Functions 97 - 112). This feature allows the operator to select the best vehicle performance for changing factory (task) conditions.

The Custom Dash Display incorporates all the features and functions of the Standard Dash Display, in addition to the following customer options:

- LED graphics to display Battery Discharge Indication status.
- Various LED indicators for Maintenance Required Status Codes. These can include options for traction, pump and power steer motors, hourmeter, over-temperature, seat belt, brake and other safety sensors.
- A push-button associated with the four segment LED that displays Status Codes can be used to scroll the last 16 "Stored Status Codes" that shut down vehicle operation with a PMT fault.

Connections

Connections are made to the Dash Display with five (5) 22-gage wires to Plug "Y" of each control. Shielded cable is required to eliminate signal interference.

Part Number

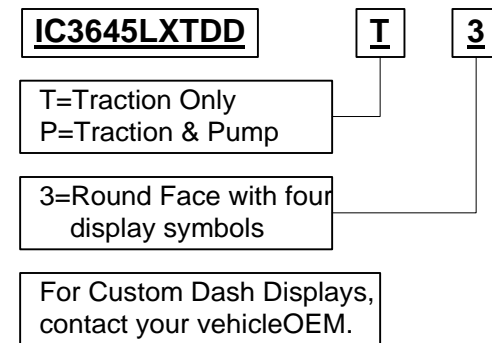

Reference

- AMP#102241-3 Dash Display mating plug
- AMP#1-87195-8 Dash Display mating pin
- 44A723596-G09 Dash Display plug kit
- AMP#776273-1 "Y" Plug
- AMP#770854-1 "Y" Plug receptacle
- 44A723596-G16 "Y" Plug Kit

Section 7.4 Start-Up Display Sequence

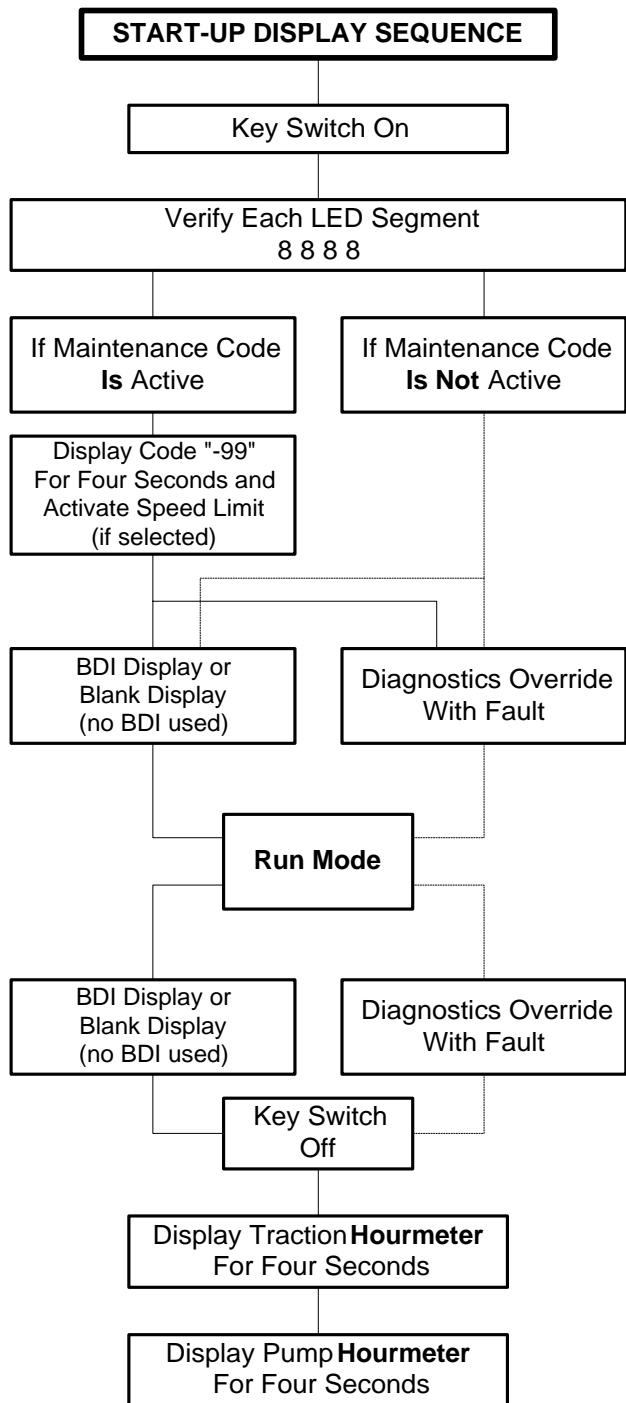

Section 7.5 Outline Drawings

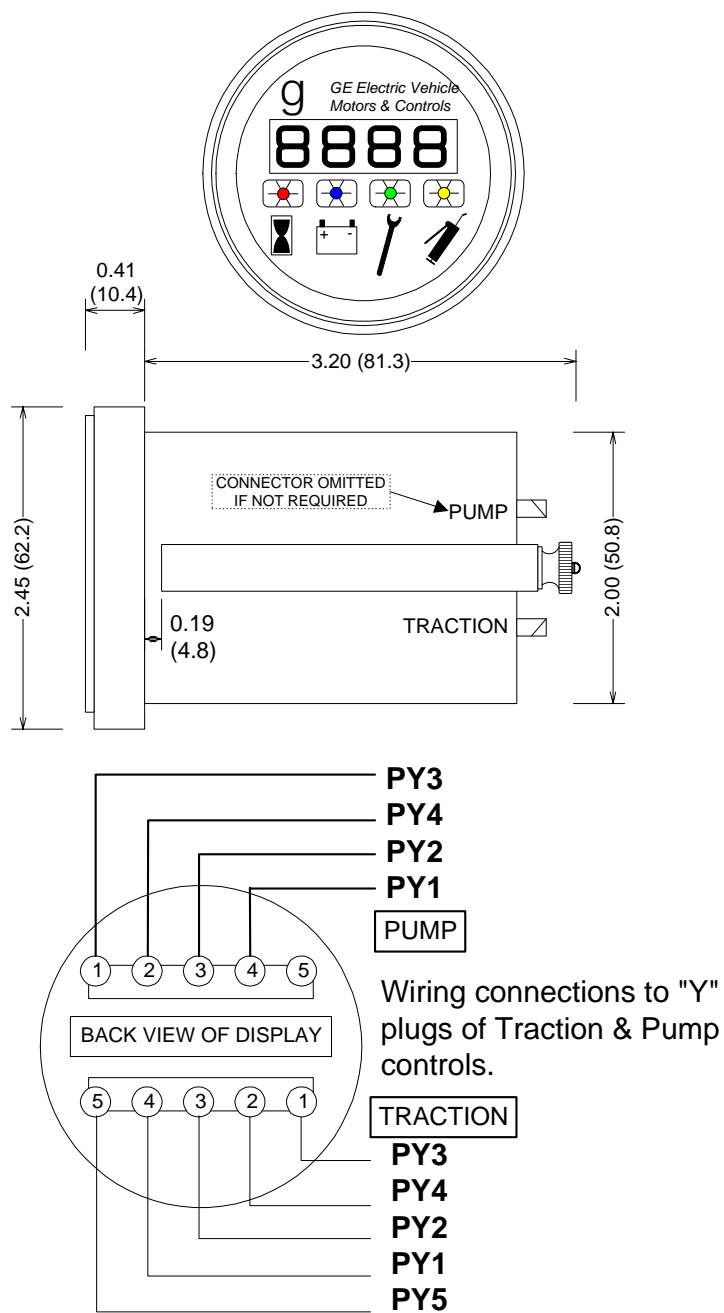

Section 8.0 TURN ANGLE POTENTIOMETER INSTALLATION

Section 8.1 GENERAL:

The potentiometer used for the turn angle must be a 320 degree rotation device that is attached to the steer wheel in a manner to cause a 1:1 rotation ratio between the two devices. Any ohm value potentiometer can be used, but it is suggested that it be at least 2K ohms or above, to keep the wattage of the potentiometer to a minimum. The turn angle potentiometer provides a voltage divider circuit that allows the left and right motor controller to determine the turn angle of the rear steer wheel of the vehicle. The potentiometer is connected to the two controls as show in Figure 1. After the potentiometer is installed on the vehicle, it will need to be adjusted to insure proper operation of the vehicle.

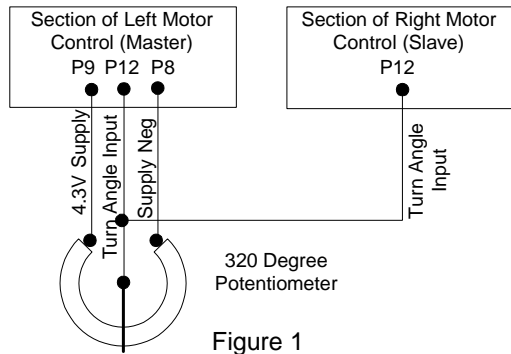

Figure 1

OPERATION:

To insure proper operation, the input voltage at P12 on both the left and right controls must coincide with the turn angle of the steer wheel. When the steer wheel is straight ahead (Zero Degree Turn Angle), the input voltage at each control should be 2.15 volts. As the vehicle turns left, this input voltage will decrease, as the vehicle turns right, the input voltage will increase. The graph in Figure 2 outlines the input voltages, the actions of the controls and the corresponding turn angles of the steer wheel. A complete listing of input voltages, steer angles and control actions can be found in **Section 8.2 - 320 Degree Potentiometer Input**. As an example of control operation as compared to the input voltage, the following series of

events takes place in a left turn from the zero to the 90 degree steer wheel position. In the first 16° of travel (2.15 to 1.90 volts), there is no change to the inside wheel speed. Between 16° (1.90V) and 66° (1.10V), the inside motor will reduce its speed proportionally from top speed at 16° to creep speed at 66°. There will also be also available two vehicle speed limit enable points during the transition from 16° to 66°. Speed limit 1 can be enabled at 41° and speed limit 2 can be enabled at 60°. Between 66° and 71°, the inside wheel will be in a free wheel mode. As the steer reaches the 71° point, the inside wheel can now be programmed to reverse and accelerate proportionally in the opposite direction. Above 86° is over travel for the turn angle potentiometer.

SETUP:

Before any adjustments are done, jack up the drive wheels.

Install the potentiometer on the vehicle steer wheel in such a way to allow adjustment of the shaft with the potentiometer and connected to both the left and right controls. Setup of the turn angle pot can be done in several ways, detailed below.

Volt Meter Method:

Attach a volt meter, positive to P12 and negative to P8. Insure that the steer wheel is pointing straight ahead (Zero Degree Angle); connect the battery and adjust the potentiometer until the voltage between P12 and P8 is 2.15 volts. Lock down the potentiometer shaft and turn the vehicle all the way to the left turn stop, the voltage should be .93 volts or less. Turn the wheel to the right turn stop, the voltage should be 3.32 volts or greater.

Handset Monitor Mode Method:

Plug the Handset into the left motor controller. Insure that the steer wheel is pointing straight ahead (Zero Degree Angle) and connect the battery. Place the Handset into the monitor routine (Function 25) to view RAM location 95, which is turn angle volts, using the following steps:

1. Push CONT 10
2. Adjust Handset to 95
3. Push STORE
4. Angle Value Displayed
5. ESC to 8888 (**To verify that you have the correct location**)
6. Push CONT 10
7. Display should read 95
8. Push STORE
9. Angle Value Displayed

Adjust the potentiometer until the Handset reads 110. Lock down the potentiometer shaft and turn the vehicle all the way to the left turn stop, the reading should be 37 or less. Turn the wheel to the right turn stop, the reading should be 183 or greater. After adjusting the potentiometer, be sure to ESC out of the monitor routine and then reset Function 25 to zero using the same procedure as outlined above.

Section 8.2 320 Degree Potentiometer Input

320 DEGREE POTENTIOMETER FOR STEER ANGLE INPUT

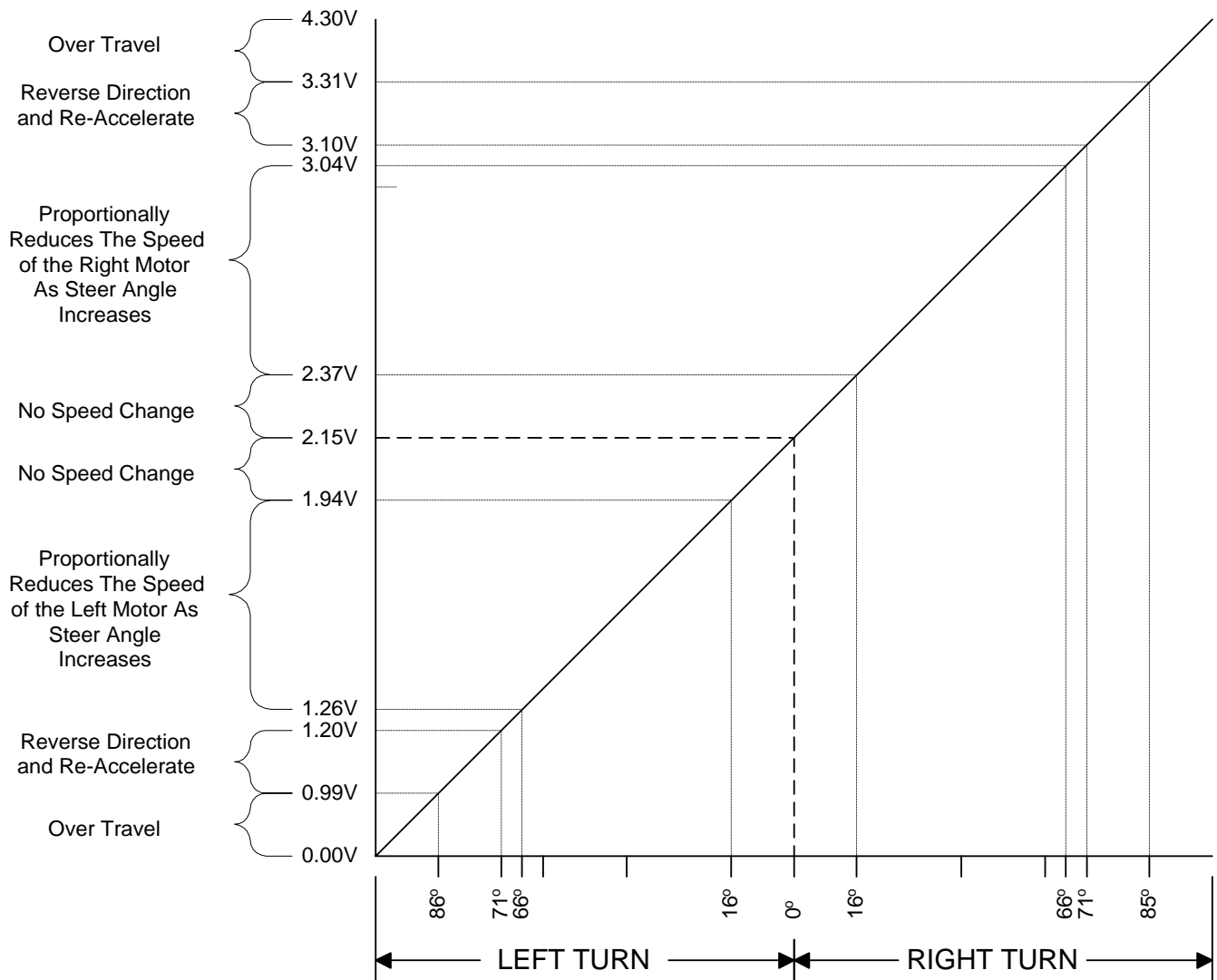

Figure 2

Section 8.3 Turn Angle Input Volts vs. Steer Wheel Degrees vs. Handset Readings

| 320 Degree Potentiometer | | | | | | |
|--------------------------|-----|-----|-------|-----|-----|---------------------|
| Left | | | Right | | | Actions |
| Volts | Deg | HS | Volts | Deg | HS | |
| 2.15 | Ctr | 110 | 2.15 | Ctr | 110 | No Change |
| 2.14 | 1 | 109 | 2.16 | 1 | 110 | No Change |
| 2.12 | 2 | 108 | 2.18 | 2 | 111 | No Change |
| 2.11 | 3 | 108 | 2.19 | 3 | 112 | No Change |
| 2.10 | 4 | 107 | 2.20 | 4 | 112 | No Change |
| 2.08 | 5 | 106 | 2.22 | 5 | 113 | No Change |
| 2.07 | 6 | 106 | 2.23 | 6 | 114 | No Change |
| 2.06 | 7 | 105 | 2.24 | 7 | 114 | No Change |
| 2.04 | 8 | 104 | 2.26 | 8 | 115 | No Change |
| 2.03 | 9 | 103 | 2.27 | 9 | 116 | No Change |
| 2.02 | 10 | 103 | 2.28 | 10 | 117 | No Change |
| 2.00 | 11 | 102 | 2.30 | 11 | 117 | No Change |
| 1.99 | 12 | 101 | 2.31 | 12 | 118 | No Change |
| 1.98 | 13 | 101 | 2.32 | 13 | 119 | No Change |
| 1.96 | 14 | 100 | 2.34 | 14 | 119 | No Change |
| 1.95 | 15 | 99 | 2.35 | 15 | 120 | No Change |
| 1.94 | 16 | 99 | 2.37 | 16 | 121 | Top Speed Reduce |
| 1.92 | 17 | 98 | 2.38 | 17 | 121 | Proportional Reduce |
| 1.91 | 18 | 97 | 2.39 | 18 | 122 | Proportional Reduce |
| 1.89 | 19 | 97 | 2.41 | 19 | 123 | Proportional Reduce |
| 1.88 | 20 | 96 | 2.42 | 20 | 123 | Proportional Reduce |
| 1.87 | 21 | 95 | 2.43 | 21 | 124 | Proportional Reduce |
| 1.85 | 22 | 95 | 2.45 | 22 | 125 | Proportional Reduce |
| 1.84 | 23 | 94 | 2.46 | 23 | 125 | Proportional Reduce |
| 1.83 | 24 | 93 | 2.47 | 24 | 126 | Proportional Reduce |
| 1.81 | 25 | 93 | 2.49 | 25 | 127 | Proportional Reduce |
| 1.80 | 26 | 92 | 2.50 | 26 | 127 | Proportional Reduce |
| 1.79 | 27 | 91 | 2.51 | 27 | 128 | Proportional Reduce |
| 1.77 | 28 | 90 | 2.53 | 28 | 129 | Proportional Reduce |
| 1.76 | 29 | 90 | 2.54 | 29 | 130 | Proportional Reduce |
| 1.75 | 30 | 89 | 2.55 | 30 | 130 | Proportional Reduce |
| 1.73 | 31 | 88 | 2.57 | 31 | 131 | Proportional Reduce |
| 1.72 | 32 | 88 | 2.58 | 32 | 132 | Proportional Reduce |
| 1.71 | 33 | 87 | 2.59 | 33 | 132 | Proportional Reduce |
| 1.69 | 34 | 86 | 2.61 | 34 | 133 | Proportional Reduce |
| 1.68 | 35 | 86 | 2.62 | 35 | 134 | Proportional Reduce |
| 1.67 | 36 | 85 | 2.63 | 36 | 134 | Proportional Reduce |
| 1.65 | 37 | 84 | 2.65 | 37 | 135 | Proportional Reduce |
| 1.64 | 38 | 84 | 2.66 | 38 | 136 | Proportional Reduce |
| 1.63 | 39 | 83 | 2.67 | 39 | 136 | Proportional Reduce |
| 1.61 | 40 | 82 | 2.69 | 40 | 137 | Proportional Reduce |
| 1.60 | 41 | 82 | 2.70 | 41 | 138 | Proportional Reduce |
| 1.59 | 42 | 81 | 2.71 | 42 | 138 | Proportional Reduce |
| 1.57 | 43 | 80 | 2.73 | 43 | 139 | Proportional Reduce |
| 1.56 | 44 | 79 | 2.74 | 44 | 140 | Proportional Reduce |
| 1.55 | 45 | 79 | 2.75 | 45 | 140 | Proportional Reduce |

| 320 Degree Potentiometer | | | | | | |
|--------------------------|-----|----|-------|-----|-----|---------------------|
| Left | | | Right | | | Actions |
| Volts | Deg | HS | Volts | Deg | HS | |
| 1.53 | 46 | 78 | 2.77 | 46 | 141 | Proportional Reduce |
| 1.52 | 47 | 77 | 2.78 | 47 | 142 | Proportional Reduce |
| 1.51 | 48 | 77 | 2.80 | 48 | 143 | Proportional Reduce |
| 1.49 | 49 | 76 | 2.81 | 49 | 143 | Proportional Reduce |
| 1.48 | 50 | 75 | 2.82 | 50 | 144 | Proportional Reduce |
| 1.46 | 51 | 75 | 2.84 | 51 | 145 | Proportional Reduce |
| 1.45 | 52 | 74 | 2.85 | 52 | 145 | Proportional Reduce |
| 1.44 | 53 | 73 | 2.86 | 53 | 146 | Proportional Reduce |
| 1.42 | 54 | 73 | 2.88 | 54 | 147 | Proportional Reduce |
| 1.41 | 55 | 72 | 2.89 | 55 | 147 | Proportional Reduce |
| 1.40 | 56 | 71 | 2.90 | 56 | 148 | Proportional Reduce |
| 1.38 | 57 | 71 | 2.92 | 57 | 149 | Proportional Reduce |
| 1.37 | 58 | 70 | 2.93 | 58 | 149 | Proportional Reduce |
| 1.36 | 59 | 69 | 2.94 | 59 | 150 | Proportional Reduce |
| 1.34 | 60 | 69 | 2.96 | 60 | 151 | Proportional Reduce |
| 1.33 | 61 | 68 | 2.97 | 61 | 151 | Proportional Reduce |
| 1.32 | 62 | 67 | 2.98 | 62 | 152 | Proportional Reduce |
| 1.30 | 63 | 66 | 3.00 | 63 | 153 | Proportional Reduce |
| 1.29 | 64 | 66 | 3.01 | 64 | 154 | Proportional Reduce |
| 1.28 | 65 | 65 | 3.02 | 65 | 154 | Proportional Reduce |
| 1.26 | 66 | 64 | 3.04 | 66 | 155 | Creep Speed |
| 1.25 | 67 | 64 | 3.05 | 67 | 156 | Zero Speed |
| 1.24 | 68 | 63 | 3.06 | 68 | 156 | Zero Speed |
| 1.22 | 69 | 62 | 3.08 | 69 | 157 | Zero Speed |
| 1.21 | 70 | 62 | 3.09 | 70 | 158 | Zero Speed |
| 1.20 | 71 | 61 | 3.10 | 71 | 158 | Reverse |
| 1.18 | 72 | 60 | 3.12 | 72 | 159 | Reverse |
| 1.17 | 73 | 60 | 3.13 | 73 | 160 | Reverse |
| 1.16 | 74 | 59 | 3.14 | 74 | 160 | Reverse |
| 1.14 | 75 | 58 | 3.16 | 75 | 161 | Reverse |
| 1.13 | 76 | 58 | 3.17 | 76 | 162 | Reverse |
| 1.12 | 77 | 57 | 3.18 | 77 | 162 | Reverse |
| 1.10 | 78 | 56 | 3.20 | 78 | 163 | Reverse |
| 1.09 | 79 | 56 | 3.21 | 79 | 164 | Reverse |
| 1.08 | 80 | 55 | 3.23 | 80 | 164 | Reverse |
| 1.06 | 81 | 54 | 3.24 | 81 | 165 | Reverse |
| 1.05 | 82 | 53 | 3.25 | 82 | 166 | Reverse |
| 1.03 | 83 | 53 | 3.27 | 83 | 167 | Reverse |
| 1.02 | 84 | 52 | 3.28 | 84 | 167 | Reverse |
| 1.01 | 85 | 51 | 3.29 | 85 | 168 | Reverse |
| 0.99 | 86 | 51 | 3.31 | 86 | 169 | Reverse |
| 0.98 | 87 | 50 | 3.32 | 87 | 169 | Over Travel |
| 0.97 | 88 | 49 | 3.33 | 88 | 170 | Over Travel |
| 0.95 | 89 | 49 | 3.35 | 89 | 171 | Over Travel |
| 0.94 | 90 | 48 | 3.36 | 90 | 171 | Over Travel |

Section 9.0 MEMORY MAPS

Section 9.1 Traction Control

| E ² | Func No. | HS No. | Traction Control Function | Access By | Restrictions |
|----------------|----------|--------|----------------------------------|-----------|----------------------|
| 0 | 1 | 1 | Motor Volts to Enable Auto Regen | HS or PC | None |
| 1 | 2 | 2 | Creep | HS or PC | None |
| 2 | 3 | 3 | Controlled Acceleration | HS or PC | None |
| 3 | 4 | 4 | Armature Current Limit | HS or PC | None |
| 4 | 5 | 5 | Plug Current Limit | HS or PC | None |
| 5 | 6 | 6 | FW Ratio | HS or PC | None |
| 6 | 7 | 7 | Minimum Field Current | HS or PC | None |
| 7 | 8 | 8 | Maximum Field Current | HS or PC | None |
| 8 | 9 | 9 | Regen Current Limit | HS or PC | None |
| 9 | 10 | 10 | Field Current for Regen | HS or PC | None |
| 10 | 11 | 11 | Turn Speed Limit | HS or PC | None |
| 11 | 12 | 12 | Max Armature % On | HS or PC | None |
| 12 | 13 | 13 | Speed Limit 3 | HS or PC | None |
| 13 | 14 | 14 | IR Compensation | HS or PC | None |
| 14 | 15 | 15 | Battery Volts Select | HS or PC | None |
| 15 | 16 | 16 | Stall Trip Point with % On-Time | HS or PC | None |
| 16 | 17 | 17 | Card Type Select | HS or PC | None |
| 17 | 18 | 18 | Steer Pump Time Delay | HS or PC | None |
| 18 | 19 | 19 | Maintenance Code HM (Tens/Units) | HS or PC | None |
| 19 | 20 | 20 | Maintenance Code HM (Thou/Hun) | HS or PC | None |
| 20 | 21 | 21 | Auto Regen | HS or PC | None |
| 21 | 22 | 22 | Not Used | HS or PC | For DD on power up |
| 22 | 23 | 23 | Not Used | HS or PC | None |
| 23 | 24 | 24 | FW Start | HS or PC | None |
| 24 | 25 | 25 | Monitor | HS or PC | GE Temporary Storage |
| 25 | 26 | 26 | Ratio | HS or PC | GE Temporary Storage |
| 26 | 27 | 27 | HM Minutes | HS or PC | GE Temporary Storage |
| 27 | 28 | 28 | Fault Count Pointer | HS or PC | None |
| 28 | 29 | 29 | Aux HM (Tens/Ones) Adj | HS or PC | None |
| 29 | 30 | 30 | Aux HM (Thou/Hun) Adj | HS or PC | None |
| 30 | 31 | | Aux HM (Tens/Ones) | PC Only | None |
| 31 | 32 | | Aux HM (Thou/Hun) | PC Only | None |
| 32 | 33 | (18) | Stored Status Code #1 | PC Only | Reset to Zero Only |
| 33 | 34 | | BDI 1 | PC Only | Reset to Zero Only |
| 34 | 35 | | Hours (Tens/Ones) 1 | PC Only | Reset to Zero Only |
| 35 | 36 | | Hours (Thou/Hun) 1 | PC Only | Reset to Zero Only |
| 36 | 37 | (20) | Stored Status Code #2 | PC Only | Reset to Zero Only |
| 37 | 38 | | BDI 2 | PC Only | Reset to Zero Only |
| 38 | 39 | | Hours (Tens/Ones) 2 | PC Only | Reset to Zero Only |
| 39 | 40 | | Hours (Thou/Hun) 2 | PC Only | Reset to Zero Only |
| 40 | 41 | (22) | Stored Status Code #3 | PC Only | Reset to Zero Only |
| 41 | 42 | | BDI 3 | PC Only | Reset to Zero Only |
| 42 | 43 | | Hours (Tens/Ones) 3 | PC Only | Reset to Zero Only |

| E ² | Func No. | HS No. | Traction Control Function | Access By | Restrictions |
|----------------|----------|--------|---------------------------|-----------|--------------------|
| 43 | 44 | | Hours (Thou/Hun) 3 | PC Only | Reset to Zero Only |
| 45 | 46 | | BDI 4 | PC Only | Reset to Zero Only |
| 46 | 47 | | Hours (Tens/Ones) 4 | PC Only | Reset to Zero Only |
| 47 | 48 | | Hours (Thou/Hun) 4 | PC Only | Reset to Zero Only |
| 48 | 49 | (26) | Stored Status Code #5 | PC Only | Reset to Zero Only |
| 49 | 50 | | BDI 5 | PC Only | Reset to Zero Only |
| 50 | 51 | | Hours (Tens/Ones) 5 | PC Only | Reset to Zero Only |
| 51 | 52 | | Hours (Thou/Hun) 5 | PC Only | Reset to Zero Only |
| 52 | 53 | (28) | Stored Status Code #6 | PC Only | Reset to Zero Only |
| 53 | 54 | | BDI 6 | PC Only | Reset to Zero Only |
| 54 | 55 | | Hours(Tens/Ones) 6 | PC Only | Reset to Zero Only |
| 55 | 56 | | Hours(Thou/Hun) 6 | PC Only | Reset to Zero Only |
| 56 | 57 | (30) | Stored Status Code #7 | PC Only | Reset to Zero Only |
| 57 | 58 | | BDI 7 | PC Only | Reset to Zero Only |
| 58 | 59 | | Hours(Tens/Ones) 7 | PC Only | Reset to Zero Only |
| 59 | 60 | | Hours(Thou/Hun) 7 | PC Only | Reset to Zero Only |
| 60 | 61 | (32) | Stored Status Code #8 | PC Only | Reset to Zero Only |
| 61 | 62 | | BDI 8 | PC Only | Reset to Zero Only |
| 62 | 63 | | Hours;(Tens/Ones) 8 | PC Only | Reset to Zero Only |
| 63 | 64 | | Hours(Thou/Hun) 8 | PC Only | Reset to Zero Only |
| 64 | 65 | (34) | Stored Status Code #9 | PC Only | Reset to Zero Only |
| 65 | 66 | | BDI 9 | PC Only | Reset to Zero Only |
| 66 | 67 | | Hours(Tens/Ones) 9 | PC Only | Reset to Zero Only |
| 67 | 68 | | Hours(Thou/Hun) 9 | PC Only | Reset to Zero Only |
| 68 | 69 | (36) | Stored Status Code #10 | PC Only | Reset to Zero Only |
| 69 | 70 | | BDI 10 | PC Only | Reset to Zero Only |
| 70 | 71 | | Hours(Tens/Ones) 10 | PC Only | Reset to Zero Only |
| 71 | 72 | | Hours(Thou/Hun) 10 | PC Only | Reset to Zero Only |
| 72 | 73 | (38) | Stored Status Code #11 | PC Only | Reset to Zero Only |
| 73 | 74 | | BDI 11 | PC Only | Reset to Zero Only |
| 74 | 75 | | Hours(Tens/Ones) 11 | PC Only | Reset to Zero Only |
| 75 | 76 | | Hours(Thou/Hun) 11 | PC Only | Reset to Zero Only |
| 76 | 77 | (40) | Stored Status Code #12 | PC Only | Reset to Zero Only |
| 77 | 78 | | BDI 12 | PC Only | Reset to Zero Only |
| 78 | 79 | | Hours(Tens/Ones) 12 | PC Only | Reset to Zero Only |
| 79 | 80 | | Hours(Thou/Hun) 12 | PC Only | Reset to Zero Only |
| 80 | 81 | (42) | Stored Status Code #13 | PC Only | Reset to Zero Only |
| 81 | 82 | | BDI 13 | PC Only | Reset to Zero Only |
| 82 | 83 | | Hours(Tens/Ones) 13 | PC Only | Reset to Zero Only |
| 83 | 84 | | Hours(Thou/Hun) 13 | PC Only | Reset to Zero Only |
| 84 | 85 | (44) | Stored Status Code # 14 | PC Only | Reset to Zero Only |
| 85 | 86 | | BDI 14 | PC Only | Reset to Zero Only |
| 86 | 87 | | Hours(Tens/Ones) 14 | PC Only | Reset to Zero Only |
| 87 | 88 | | Hours(Thou/Hun) 14 | PC Only | Reset to Zero Only |
| 88 | 89 | (46) | Stored Status Code # 15 | PC Only | Reset to Zero Only |
| 89 | 90 | | BDI 15 | PC Only | Reset to Zero Only |
| 90 | 91 | | Hours (Tens/Ones) 15 | PC Only | Reset to Zero Only |

| E ² | Func No. | HS No. | Traction Control Function | Access By | Restrictions |
|----------------|----------|-------------|--------------------------------|-----------|--------------------|
| 90 | 91 | | Hours (Tens/Ones) 15 | PC Only | Reset to Zero Only |
| 91 | 92 | | Hours (Thou/Hun) 15 | PC Only | Reset to Zero Only |
| 92 | 93 | (48) | Stored Status Code #16 | PC Only | Reset to Zero Only |
| 94 | 95 | | Hours (Tens/Ones) 16 | PC Only | Reset to Zero Only |
| 95 | 96 | | Hours (Thou/Hun) 16 | PC Only | Reset to Zero Only |
| 96 | 67 | 48 | Dash Display CA-1 | | |
| 97 | 98 | 49 | Dash Display FWS-1 | HS or PC | None |
| 98 | 99 | 50 | Dash Display Ratio2-1 | HS or PC | None |
| 99 | 100 | 51 | Dash Display Speed Limit 2 - 1 | HS or PC | None |
| 100 | 101 | 52 | Dash Display CA-2 | HS or PC | None |
| 101 | 102 | 53 | Dash Display FWS-2 | HS or PC | None |
| 102 | 103 | 54 | Dash Display Ratio2-2 | HS or PC | None |
| 103 | 104 | 55 | Dash Display Speed Limit 2 - 2 | HS or PC | None |
| 104 | 105 | 56 | Dash Display CA-3 | HS or PC | None |
| 105 | 106 | 57 | Dash Display FWS-3 | HS or PC | None |
| 106 | 107 | 58 | Dash Display Ratio2-3 | HS or PC | None |
| 107 | 108 | 59 | Dash Display Speed Limit 2 - 3 | HS or PC | None |
| 108 | 109 | 60 | Dash Display CA-4 | HS or PC | None |
| 109 | 110 | 61 | Dash Display FWS-4 | HS or PC | None |
| 110 | 111 | 62 | Dash Display Ratio2-4 | HS or PC | None |
| 111 | 112 | 63 | Dash Display Speed Limit 2 - 4 | HS or PC | None |
| 112 | 113 | | Secure HM (Tens/Ones) | PC Only | OEM Read Only |
| 113 | 114 | | Secure HM (Thou/Hun) | PC Only | OEM Read Only |
| 114 | 115 | | Secure Aux HM (Tens/Ones) | PC Only | OEM Read Only |
| 115 | 116 | | Secure Aux HM (Thou/Hun) | PC Only | OEM Read Only |
| 116 | 117 | | Field Offset | PC Only | GE Read Only |
| 117 | 118 | | Field Offset | PC Only | GE Read Only |
| 118 | 119 | | Armature Offset | PC Only | GE Read Only |
| 119 | 120 | | Reserved | PC Only | GE Future Use |
| 120 | 121 | | OEM Use | PC Only | None |
| 121 | 122 | | OEM Use | PC Only | None |
| 122 | 123 | | OEM Use | PC Only | None |
| 123 | 124 | | OEM Use | PC Only | None |
| 124 | 125 | | OEM Use | PC Only | None |
| 125 | 126 | | OEM Use | PC Only | None |
| 126 | 127 | | OEM Use | PC Only | None |
| 127 | 128 | | OEM Use | PC Only | None |

Numbers in ***(bold italics)*** are Stored Status Code pointers.

Section 9.2 Pump Control

| E ² | Func No. | HS No. | Pump Control Function | Access By | Restrictions |
|----------------|----------|-------------|------------------------------|-----------|---|
| 0 | 1 | 1 | Fault Code | HS or PC | Lost when battery is disconnected |
| 1 | 2 | 2 | IR Start | HS or PC | None |
| 2 | 3 | 3 | C/A | HS or PC | None |
| 3 | 4 | 4 | C/L | HS or PC | None |
| 4 | 5 | 5 | Not Used | HS or PC | None |
| 5 | 6 | 6 | Not Used | HS or PC | None |
| 6 | 7 | 7 | IR Compensation Rate | HS or PC | None |
| 7 | 8 | 8 | Not Used | HS or PC | None |
| 8 | 9 | 9 | Not Used | HS or PC | None |
| 9 | 10 | 10 | Not Used | HS or PC | None |
| 10 | 11 | 11 | Speed Limit (SL1) | HS or PC | None |
| 11 | 12 | 12 | Speed Limit (SL2) | HS or PC | None |
| 12 | 13 | 13 | Speed Limit (SL3) | HS or PC | None |
| 13 | 14 | 14 | Speed Limit (SL4) | HS or PC | None |
| 14 | 15 | 15 | Not Used | HS or PC | None |
| 15 | 16 | 16 | Speed/Torque Compensation | HS or PC | None |
| 16 | 17 | 17 | Card Type Select | HS or PC | None |
| 17 | 18 | 18 | Not Used | HS or PC | None |
| 18 | 19 | 19 | Not Used | HS or PC | None |
| 19 | 20 | 20 | Not Used | HS or PC | None |
| 20 | 21 | 21 | Not Used | HS or PC | None |
| 21 | 22 | 22 | Mode Reference | HS or PC | For dash display on battery power up |
| 22 | 23 | 23 | Hourmeter (Min) | HS or PC | None |
| 23 | 24 | 24 | Hourmeter (Sec) | HS or PC | None |
| 24 | 25 | 25 | Fault Reg Data | HS or PC | GE Temporary Storage |
| 25 | 26 | 26 | Not Used | HS or PC | None |
| 26 | 27 | 27 | Not Used | HS or PC | None |
| 27 | 28 | 28 | Fault Count Pointer | HS or PC | None (Location of last fault code recorded) |
| 28 | 29 | 29 | HM (Tens/Ones) | HS or PC | None |
| 29 | 30 | 30 | HM (Thou/Hun) | HS or PC | None |
| 30 | 31 | | Aux HM (Tens/Ones) | PC Only | None |
| 31 | 32 | | Aux HM (Thous/Hun) | PC Only | None |
| 32 | 33 | (18) | <i>Stored Status Code #1</i> | PC Only | Reset to Zero Only |
| 33 | 34 | | Not Used | PC Only | None |
| 34 | 35 | | Hours (Tens/Ones) 1 | PC Only | Reset to Zero Only |
| 35 | 36 | | Hours (Thou/Hun) 1 | PC Only | Reset to Zero Only |
| 36 | 37 | (20) | <i>Stored Status Code #2</i> | PC Only | Reset to Zero Only |
| 37 | 38 | | Not Used | PC Only | None |
| 38 | 39 | | Hours (Tens/Ones) 2 | PC Only | Reset to Zero Only |
| 39 | 40 | | Hours (Thou/Hun) 2 | PC Only | Reset to Zero Only |
| 40 | 41 | (22) | <i>Stored Status Code #3</i> | PC Only | Reset to Zero Only |
| 41 | 42 | | Not Used | PC Only | None |
| 42 | 43 | | Hours (Tens/Ones) 3 | PC Only | Reset to Zero Only |
| 43 | 44 | | Hours (Thou/Hun) 3 | PC Only | Reset to Zero Only |

Numbers in ***(bold italics)*** are Stored Status Code Pointers.

| E ² | Func No. | HS No. | Pump Control Function | Access By | Restrictions |
|----------------|----------|-------------|-------------------------------|-----------|--------------------|
| 44 | 45 | (24) | <i>Stored Status Code #4</i> | PC Only | Reset to Zero Only |
| 45 | 46 | | Not Used | PC Only | None |
| 46 | 47 | | Hours (Tens/Ones) 4 | PC Only | Reset to Zero Only |
| 47 | 48 | | Hours (Thou/Hun) 4 | PC Only | Reset to Zero Only |
| 48 | 49 | (26) | <i>Stored Status Code #5</i> | PC Only | Reset to Zero Only |
| 49 | 50 | | Not Used | PC Only | None |
| 50 | 51 | | Hours (Tens/Ones) 5 | PC Only | Reset to Zero Only |
| 51 | 52 | | Hours (Thou/Hun) 5 | PC Only | Reset to Zero Only |
| 52 | 53 | (28) | <i>Stored Status Code #6</i> | PC Only | Reset to Zero Only |
| 53 | 54 | | Not Used | PC Only | None |
| 54 | 55 | | Hours (Tens/Ones) 6 | PC Only | Reset to Zero Only |
| 55 | 56 | | Hours (Thou/Hun) 6 | PC Only | Reset to Zero Only |
| 56 | 57 | (30) | <i>Stored Status Code #7</i> | PC Only | Reset to Zero Only |
| 57 | 58 | | Not Used | PC Only | None |
| 58 | 59 | | Hours (Tens/Ones) 7 | PC Only | Reset to Zero Only |
| 59 | 60 | | Hours (Thou/Hun) 7 | PC Only | Reset to Zero Only |
| 60 | 61 | (32) | <i>Stored Status Code #8</i> | PC Only | Reset to Zero Only |
| 61 | 62 | | Not Used | PC Only | None |
| 62 | 63 | | Hours (Tens/Ones) 8 | PC Only | Reset to Zero Only |
| 63 | 64 | | Hours (Thou/Hun) 8 | PC Only | Reset to Zero Only |
| 64 | 65 | (34) | <i>Stored Status Code #9</i> | PC Only | Reset to Zero Only |
| 65 | 66 | | Not Used | PC Only | None |
| 66 | 67 | | Hours (Tens/Ones) 9 | PC Only | Reset to Zero Only |
| 67 | 68 | | Hours (Thou/Hun) 9 | PC Only | Reset to Zero Only |
| 68 | 69 | (36) | <i>Stored Status Code #10</i> | PC Only | Reset to Zero Only |
| 69 | 70 | | Not Used | PC Only | None |
| 70 | 71 | | Hours (Tens/Ones) 10 | PC Only | Reset to Zero Only |
| 71 | 72 | | Hours (Thou/Hun) 10 | PC Only | Reset to Zero Only |
| 72 | 73 | (38) | <i>Stored Status Code #11</i> | PC Only | Reset to Zero Only |
| 73 | 74 | | Not Used | PC Only | None |
| 74 | 75 | | Hours (Tens/Ones) 11 | PC Only | Reset to Zero Only |
| 75 | 76 | | Hours (Thou/Hun) 11 | PC Only | Reset to Zero Only |
| 76 | 77 | (40) | <i>Stored Status Code #12</i> | PC Only | Reset to Zero Only |
| 77 | 78 | | Not Used | PC Only | None |
| 78 | 79 | | Hours (Tens/Ones) 12 | PC Only | Reset to Zero Only |
| 79 | 80 | | Hours (Thou/Hun) 12 | PC Only | Reset to Zero Only |
| 80 | 81 | (42) | <i>Stored Status Code #13</i> | PC Only | Reset to Zero Only |
| 81 | 82 | | Not Used | PC Only | None |
| 82 | 83 | | Hours (Tens/Ones) 13 | PC Only | Reset to Zero Only |
| 83 | 84 | | Hours (Thou/Hun) 13 | PC Only | Reset to Zero Only |
| 84 | 85 | (44) | <i>Stored Status Code #14</i> | PC Only | Reset to Zero Only |
| 85 | 86 | | Not Used | PC Only | None |
| 86 | 87 | | Hours (Tens/Ones) 14 | PC Only | Reset to Zero Only |
| 87 | 88 | | Hours (Thou/Hun) 14 | PC Only | Reset to Zero Only |

Numbers in ***(bold italics)*** are Stored Status Code Pointers.

| E ² | Func No. | HS No. | Pump Control Function | Access By | Restrictions |
|----------------|----------|-------------|-------------------------------|-----------|--------------------|
| 88 | 89 | (46) | <i>Stored Status Code #15</i> | PC Only | Reset to Zero Only |
| 89 | 90 | | Not Used | PC Only | None |
| 90 | 91 | | Hours (Tens/Ones) 15 | PC Only | Reset to Zero Only |
| 91 | 92 | | Hours (Thou/Hun) 15 | PC Only | Reset to Zero Only |
| 92 | 93 | (48) | <i>Stored Status Code #16</i> | PC Only | Reset to Zero Only |
| 93 | 94 | | Not Used | PC Only | None |
| 94 | 95 | | Hours (Tens/Ones) 16 | PC Only | Reset to Zero Only |
| 95 | 96 | | Hours (Thou/Hun) 16 | PC Only | Reset to Zero Only |
| 96 | 97 | 48 | Dash Display CA-1 | HS or PC | None |
| 97 | 98 | 49 | Dash Display SL2-1 | HS or PC | None |
| 98 | 99 | 50 | Dash Display SL4-1 | HS or PC | None |
| 99 | 100 | 51 | Not Used-1 | HS or PC | None |
| 100 | 101 | 52 | Dash Display CA-2 | HS or PC | None |
| 101 | 102 | 53 | Dash Display SL2-2 | HS or PC | None |
| 102 | 103 | 54 | Dash Display SL4-2 | HS or PC | None |
| 103 | 104 | 55 | Not Used-2 | HS or PC | None |
| 104 | 105 | 56 | Dash Display CA-3 | HS or PC | None |
| 105 | 106 | 57 | Dash Display SL2-3 | HS or PC | None |
| 106 | 107 | 58 | Dash Display SL4-3 | HS or PC | None |
| 107 | 108 | 59 | Not Used-3 | HS or PC | None |
| 108 | 109 | 60 | Dash Display CA-4 | HS or PC | None |
| 109 | 110 | 61 | Dash Display SL2-4 | HS or PC | None |
| 110 | 111 | 62 | Dash Display SL4-4 | HS or PC | None |
| 111 | 112 | | Not Used-4 | PC Only | None |
| 112 | 113 | | Secure HM (Tens/Ones) | PC Only | OEM Read Only |
| 113 | 114 | | Secure HM (Thou/Hun) | PC Only | OEM Read Only |
| 114 | 115 | | Sec Aux HM (Tens/Ones) | PC Only | OEM Read Only |
| 115 | 116 | | Sec Aux HM (Thou/Hun) | PC Only | OEM Read Only |
| 116 | 117 | | Reserved | PC Only | GE Future Use Only |
| 117 | 118 | | Reserved | PC Only | GE Future Use Only |
| 118 | 119 | | Armature Offset | PC Only | GE Read Only |
| 119 | 120 | | Reserved | PC Only | GE Future Use Only |
| 120 | 121 | | OEM Use | PC Only | None |
| 121 | 122 | | OEM Use | PC Only | None |
| 122 | 123 | | OEM Use | PC Only | None |
| 123 | 124 | | OEM Use | PC Only | None |
| 124 | 125 | | OEM Use | PC Only | None |
| 125 | 126 | | OEM Use | PC Only | None |
| 126 | 127 | | OEM Use | PC Only | None |
| 127 | 128 | | OEM Use | PC Only | None |

Numbers in **(bold italics)** are Stored Status Code Pointers.