

**SEPARATELY EXCITED (SX) TRANSISTORIZED DUAL MOTOR TRACTION CONTROLLERS
 INSTALLATION AND OPERATION MANUAL
 (IC3645SR4R333AS1)**

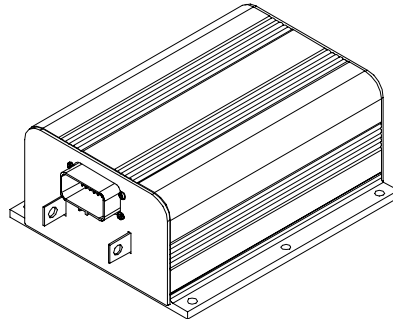

Note: The information contained herein is intended to assist OEM's, Dealers and Users of electric vehicles in the application, installation and service of GE solid-state controllers. This manual does not purport to cover all variations in OEM vehicle types. Nor does it provide for every possible contingency to be met involving vehicle installation, operation or maintenance. For additional information and/or problem resolution, please refer the matter to the OEM vehicle manufacturer through his normal field service channels. Do not contact GE directly for this assistance.

Table of Contents

Copyright by General Electric Company April 1999

Section 1.0	INTRODUCTION	4
	1.1 Motor Characteristics	4
	1.2 Solid-State Reversing	5
	1.3 Flexible System Application.....	5
	1.4 More Features with Fewer Components	5
Section 2.0	FEATURES OF SX FAMILY OF MOTOR CONTROLLERS	6
	2.1 Performance	6
	2.1.1 Oscillator Card Features	6
	2.1.1.a Standard Operation	6
	2.1.1.b Creep Speed.....	6
	2.1.1.c Control Acceleration	6
	2.1.2 Current Limit	6
	2.1.3 Braking.....	6
	2.1.3.a Regenerative Braking to Zero Speed	6
	2.1.3.b Auto Braking.....	6
	2.1.4 Auxiliary Speed Control.....	6
	2.1.4.a Field Weakening.....	6
	2.1.4.b Speed Limits	6
	2.1.5 Ramp Start	7
	2.1.6 On-Board Coil Drivers and Internal Coil Suppression	7
	2.2 System Protective Override	7
	2.2.1 Static Return to Off (SRO)	7
	2.2.2 Accelerator Volts Hold Off.....	7

Table of Contents (Continued)

2.2.3	Pulse Monitor Trip (PMT).....	7
2.2.4	Thermal Protector (TP).....	7
2.2.5	Low Voltage	7
2.3	Diagnostics.....	7
2.3.1	Systems Diagnostics.....	7
2.3.2	Status Codes.....	7
2.3.2.a	Standard Status Codes.....	7
2.3.2.b	Stored Status Codes	8
2.3.3	Hourmeter Readings	8
2.3.4	Battery Discharge Indication (BDI).....	8
2.3.4.a	Internal Resistance Compensation	8
2.3.5	Handset	8
2.3.6	RS-232 Communication Port	8
2.3.6.a	Interactive Dash Display Modes.....	8
2.3.7	Circuit Board Coil Driver Modules.....	8
Section 3.0	ORDERING INFORMATION, ELEMENTARY AND OUTLINE DRAWINGS.....	9
3.1	Ordering Information for Separately Excited Controls.....	9
3.2	Outline: SX-2 Package Size.....	10
3.3	Dual Motor Proportioning Drive Elementary	11
3.4	Dual Motor Proportioning Drive Input / Output List.....	12
Section 4.0	TROUBLESHOOTING AND DIAGNOSTIC STATUS CODES.....	13
4.1	General Maintenance Instructions.....	13
4.2	Cable Routing and Separation	13
4.2.1	Application Responsibility	13
4.2.2	Signal/Power Level Definitions.....	13
4.2.2.a	Low Level Signals (Level L)	13
4.2.2.b	High Level Signals (Level H).....	14
4.2.2.c	Medium-Power Signals (Level MP)	14
4.2.2.d	High-Power Signals (Level HP)	14
4.2.3	Cable Spacing Guidelines	14
4.2.3.a	General Cable Spacing.....	14
4.2.4	Cabling for Vehicle Retrofits	14
4.2.5	RF Interference.....	14
4.2.6	Suppression.....	14
4.3	Recommended Lubrication of Pins and Sockets Prior to Installation.....	15
4.4	General Troubleshooting Instructions	15
4.5	Traction Controller Status Codes.....	16-29
Section 5.0	SX FAMILY - GE HANDSET INSTRUCTIONS	30
5.1	General Features	30
5.2	Purpose/Setup Functions	30
5.3	Setup Function Procedures	31
5.3.1	Setup Mode	31
5.3.2	Status Code Scrolling.....	31
5.3.3	SX Handset Plug Connections & Outline Drawing.....	31
5.4	Setup Functions for Traction Controller	32-36
5.5	Summary of Current Limit Adjustments.....	37

Table of Contents (Continued)

Section 6.0	DISPLAYS.....	38
6.1	Application	38
6.2	Standard Dash Displays	38
6.3	Interactive Custom Dash Displays.....	38
6.3.1	Connections.....	38
6.3.2	Part Numbers	38
6.3.3	Connector Reference Numbers.....	39
6.4	Start-up Display Sequence	39
6.5	Outline Drawings	39
6.6	Suggested Wiring Configuration for Use of GE Standard Traction/Pump Dash Display Motor Traction System	40
Section 7.0	MEMORY MAPS.....	41
7.1	Typical Memory Map for DM Proportioning Control	41-43

Section 1. INTRODUCTION

Section 1.1 Motor Characteristics

The level of sophistication in the controllability of traction motors has changed greatly over the past several years. Vehicle manufacturers and users are continuing to expect more value and flexibility in electric vehicle motor and control systems as they are applied today. In order to respond to these market demands, traction system designers have been forced to develop new approaches to reduce cost and improve functions and features of the overall system. Development is being done in a multi-generational format that allows the market to take advantage of today's technology, while looking forward to new advances on the horizon. GE has introduced a second generation system using separately excited DC shunt wound motors. The separately excited DC motor system offers many of the features that are generally found on the advanced AC systems. Historically, most electric vehicles have relied on series motor designs because of their ability to produce very high levels of torque at low speeds. But, as the demand for high efficiency systems increases, i.e., systems that are more closely applied to customers' specific torque requirements, shunt motors are now often being considered over series motors. In most applications, by independently controlling the field and armature currents in the separately excited motor, the best attributes of both the series and the shunt wound motors can be combined.

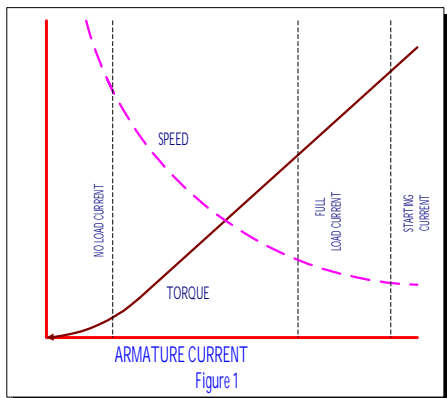

As shown in from the typical performance curves of Figure 1, the high torque at low speed characteristic of the series motor is evident.

In a shunt motor, the field is connected directly across the voltage source and is therefore independent of variations in load and armature current. If field strength is held constant, the torque developed will vary directly with the armature current. If the mechanical load on the motor increases, the motor slows down, reducing the back EMF (which depends on the speed, as well as the constant field strength). The reduced back EMF allows the armature

current to increase, providing the greater torque needed to drive the increased mechanical load. If the mechanical load is decreased, the process reverses. The motor speed and the back EMF increase, while the armature current and the torque developed decrease. Thus, whenever the load changes, the speed changes also, until the motor is again in electrical balance.

In a shunt motor, the variation of speed from no load to normal full load on level ground is less than 10%. For this reason, shunt motors are considered to be constant speed motors (Figure 2).

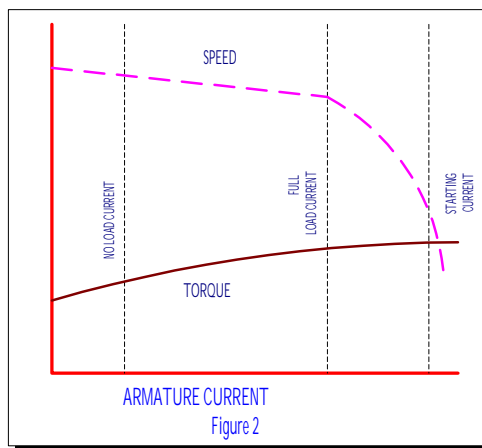

In the separately excited motor, the motor is operated as a fixed field shunt motor in the normal running range. However, when additional torque is required, for example, to climb non-level terrain, such as ramps and the like, the field current is increased to provide the higher level of torque. In most cases, the armature to field ampere turn ratio can be very similar to that of a comparable size series motor (Figure 3.)

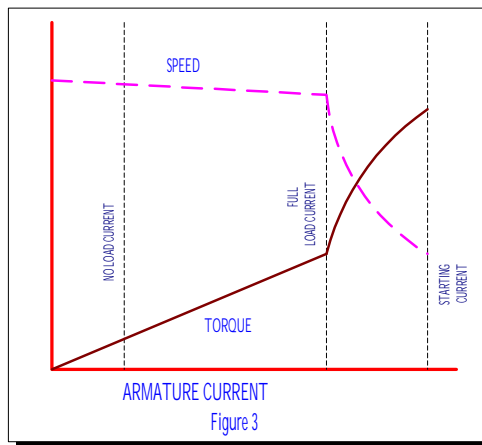

Aside from the constant horsepower characteristics described above, there are many other features that provide increased performance and lower cost. The

following description provides a brief introduction to examples of some of these features.

Section 1. 2 Solid-State Reversing

The direction of armature rotation on a shunt motor is determined by the direction in which current flows through the field windings. Because the shunt motor field only typically requires about 10% of the armature current at full torque, it is normally cost effective to replace the double-pole, double-throw reversing contactor with a low power transistor H-Bridge circuit (Figure 4).

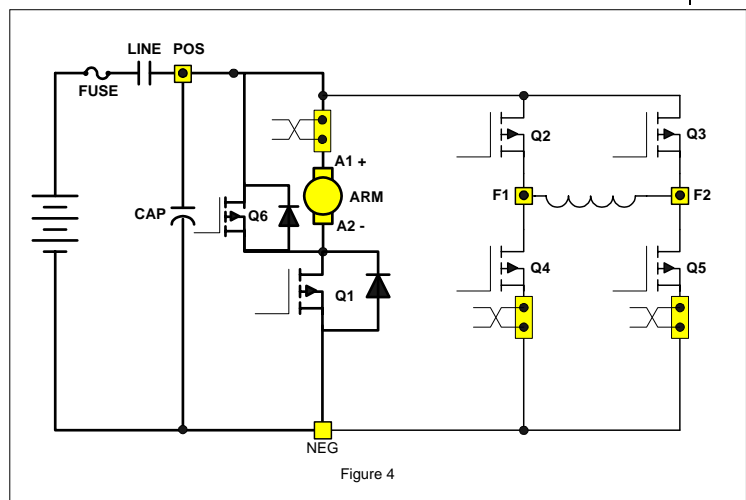

Figure 4

By energizing the transistors in pairs, current can be made to flow in either direction in the field. The field control circuit operates at 2 KHZ, and the armature control circuit typically operates at 12KHZ, a frequency normally above human hearing. This high frequency coupled with the elimination of directional contactors, provides very quiet vehicle operation.

The line contactor is normally the only contactor required for the shunt motor traction circuit. This contactor is used for both pre-charge of the line capacitors and for emergency shut down of the motor circuit, in case of problems that would cause a full motor torque condition. The line can be energized and de-energized by the various logic combinations of the vehicle, i.e. activate on key, seat or start switch closure, and de-energize on time out of idle vehicle. Again, these options add to the quiet operation of the vehicle.

Section 1. 3 Flexible System Application

Because the shunt motor controller has the ability to control both the armature and field circuits independently, the system can normally be adjusted for maximum system efficiencies at certain operating parameters. Generally speaking, with the ability of independent field and

armature, the motor performance curve can be maximized through proper control application.

Section 1. 4 More Features with Fewer Components

Field weakening with a series wound motor is accomplished by placing a resistor in parallel with the field winding of the motor. Bypassing some of the current flowing in the field into the resistor causes the field current to be less, or weakened. With the field weakened, the motor speed will increase, giving the effect of "overdrive". To change the "overdrive speed", it is necessary to change the resistor value. In a separately excited motor, independent control of the field current provides for infinite adjustments of "overdrive" levels, between motor base speed and maximum weak field. The desirability of this feature is enhanced by the elimination of the contactor and resistor required for field weakening with a series motor.

With a separately excited motor, overhauling speed limit, or downhill speed, will also be more constant. By its nature, the shunt motor will try to maintain a constant speed downhill. This characteristic can be enhanced by increasing the field strength with the control. Overhauling load control works in just the opposite way of field weakening, armature rotation slows with the increase of current in the field. An extension of this feature is a zero-speed detect feature which prevents the vehicle from free-wheeling down an incline, should the operator neglect to set the brake.

Regenerative braking (braking energy returned to the battery) may be accomplished completely with solid-state technology. The main advantage of regenerative braking is increased motor life. Motor current is reduced by 50% or more during braking while maintaining the same braking torque as electrical braking with a diode clamp around the armature. The lower current translates into longer brush life and reduced motor heating. Solid state regenerative braking also eliminates a power diode, current sensor and contactor from the circuit.

For GE, the future is now as we make available a new generation of electric traction motor systems for electric vehicles having separately excited DC shunt motors and controls. Features that were once thought to be only available on future AC or brushless DC technology vehicles systems are now achievable and affordable.

Section 2. FEATURES OF SX FAMILY OF TRANSISTOR MOTOR CONTROLLERS

Section 2.1 Performance

Section 2.1.1 Oscillator Card Features

Section 2.1.1.a Standard Operation

The oscillator section of the card has two adjustable features, creep speed and minimum field current. With the accelerator at maximum ohms or volts, the creep speed can be adjusted by Function 2 of the Handset or a trimpot. The field control section allows the adjustment of the field weakening level in order to set the top speed of the motor. This top speed function (Minimum Field Current) is enabled when the armature current is less than the value set by Function 24 and the accelerator input voltage is less than 1 volt. Top Speed can be adjusted by Function 7 of the Handset or a trimpot.

The percent on-time has a range of approximately 0 to 100 percent. The SX controllers operate at a constant frequency and the percent on-time is controlled by the pulse width of the voltage / current applied to the motor circuits.

Section 2.1.1.b Creep Speed

With the accelerator at maximum ohms or volts (approximately 3.7 to 3.5 VDC), the creep speed can be adjusted by Function 2 of the Handset. At creep speed, the ON time can decrease to approximately 5%, with the OFF time at approximately 95%. At full transistor operation, this condition will be reversed (short OFF time, long ON time). This variation of ON and OFF time of the oscillator varies the voltage applied to the motor, thereby varying the speed of the motor for a given load.

Section 2.1.1.c Control Acceleration

This feature allows for adjustment of the rate of time it takes for the control to accelerate to 100% applied battery voltage to the motor on hard acceleration. C/A is adjusted by Function 3 from 0.1 to 22 seconds.

Section 2.1.2 Current Limit

This circuit monitors motor current by utilizing sensors in series with the armature and field windings. The information detected by the sensor is fed back to the card so that current may be limited to a pre-set value. If heavy load currents are detected, this circuit overrides the oscillator and limits the average current to a value set by Function 4 and Function 8 of the Handset. The C/L setting is based on the maximum thermal rating of the control. Because of the flyback current through 3REC, the motor

current is usually greater than battery current, except at 100% ON time.

Section 2.1.3 Braking

Section 2.1.3.a Regenerative Braking to Zero Speed

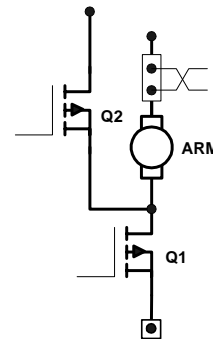

Slow down is accomplished when reversing direction by providing a small amount of retarding torque for deceleration. If the vehicle is moving, and the directional lever is moved from one direction to the other, the regen signal is initiated. Once the regen signal has been initiated, the field current is increased. Armature current is regulated to the regen current limit

as set by Function 9. As the vehicle slows down, the field current continues to increase, and transistor Q2 begins to chop. The field current will increase until it reaches a preset value set by Function 10, and transistor Q2 on-time will increase until it reaches 100% on-time. Once both of the above conditions have been met, and regen current limit can no longer be maintained, the braking function is canceled. The fields will then reverse, and the control reverts back to motoring.

Part of the energy produced by the motor during regen is returned to the battery, and part is dumped in the motor as heat.

Section 2.1.3.b Auto Braking

This feature is enabled by initiating a "neutral position" using either the directional switch or the accelerator switch.

Section 2.1.3.c Overspeed Regenerative Braking

Overspeed regenerative braking provides a means of controlling the speed of a vehicle in operation on an incline. The feature is enabled when the tachometer pulses seen by the control exceed the values set by Function 11 or 12. Once this occurs, the control will provide retarding torque to regulate the vehicle speed, as determined by Functions 11 and 12.

Section 2.1.4 Auxiliary Speed Control

Section 2.1.4.a Field Weakening

This function allows the adjustment of the field weakening level in order to set the top speed of the motor. The function is enabled when the armature current is less than the value set by Function 24 and the accelerator input voltage is less than 1 volt. It is important to note that this function is used to optimize motor and control performance, and this setting

will be determined by GE and OEM engineers at the time of vehicle development. This setting must not be changed by field personnel without the permission of the OEM.

Section 2.1.4.b Speed Limits

This feature provides a means to control speed by re-scaling the maximum number of tachometer pulses to a set value at the maximum throttle to be regulated. These speeds are set by Functions 11 and 12. These speed limits are activated by a normally open switch to positive 12 volts.

Section 2.1.5 Ramp Start

This feature provides maximum control torque to restart a vehicle on an incline. The memory for this function is the directional switch. When stopping on an incline, the directional switch must be left in its original or neutral position to allow the control to initiate full power when restarted. The accelerator potentiometer input will modulate ramp start current.

Section 2.1.6 On-Board Coil Drivers & Internal Coil Suppression

Coil drivers for the LINE and SP or BYPASS contactors are on-board the control card. These contactors must have coils rated for the vehicle battery volts.

Section 2.2 System Protective Override

Section 2.2.1 Static Return to Off (SRO)

This inherent feature of the control is designed to require the driver to return the directional lever to the neutral position anytime he removes his foot from the foot switch.

Section 2.2.2 Accelerator Volts Hold Off

This feature checks the voltage level at the accelerator input whenever the key switch or seat switch is activated. If, at start up, the voltage is less than 3.0 volts, the control will not operate. This feature assures that the control is calling for low speed operation at start up.

Section 2.2.3 Pulse Monitor Trip (PMT)

The PMT design contains three features which shut down, or lock out, control operation if a fault conditions occurs that would cause a disruption of normal vehicle operation:

- Look ahead
- Look again
- Automatic look again and reset

The PMT circuit will not allow the control to start under the following conditions:

- The control monitors both armature and field FET's at start-up and during running.
- The control will not allow the line contactor to close at start-up, or will drop it out during running, if either the armature or field FET's are defective, so as to cause uncontrolled truck movement.

Section 2.2.4 Thermal Protector (TP)

This temperature sensitive device is internal to the power transistor (Q1) module. If the transistor's temperature begins to exceed the design limits, the thermal protector will lower the maximum current limit, and maintain the transistors within their temperature limits. As the control cools, the thermal protector will automatically reset, returning the control to full power.

Section 2.2.5 Low Voltage

Batteries under load, particularly if undersized or more than 80 percent discharged, will produce low voltages at the control terminals. The SX control is designed for use down to 50 percent of a nominal battery voltage of 36-84 volts, and 75 percent of a nominal battery voltage of 24 volts. Lower battery voltage may cause the control to operate improperly, however, the resulting PMT should open the Line contactor, in the event of a failure.

Section 2.3 Diagnostics

Section 2.3.1 Systems Diagnostics

The control detects the system's present operating status and can be displayed to either the Dash Display or the Handset. There are currently over 70 status codes that are available with SX systems using Traction and Pump controls and Truck Management Module (TMM). Along with the status code display from the TMM, the SX control is capable of reducing the current to the motor, alerting the operator of a critical fault condition.

Section 2.3.2 Status Codes

Section 2.3.2a Standard Status Codes

The SX traction control has over 30 Status Codes that assist the service technician and operator in trouble shooting the vehicle. If mis-operation of the vehicle occurs, a status code will be displayed on the Dash Display for vehicles so equipped, or be available by plugging the Handset into the "y" plug of the logic card.

With the status code number, follow the procedures outlined in DIAGNOSTIC STATUS CODES to determine the problem and a solution.

Note: The Status Code Instruction Sheets do not purport to cover all possible causes of a display of a "status code". They do provide instructions for checking the most direct inputs that can cause status codes to appear.

Section 2.3.2.b Stored Status Codes

This feature records the last 16 "Stored Status Codes" that have caused a PMT controller shut down and/or disrupted normal vehicle operation. (PMT type faults are reset by cycling the key switch). These status codes, along with the corresponding BDI and hourmeter readings, can be accessed with the Handset, or by using the RS 232 communications port and dumping the information to a Personal Computer terminal.

Section 2.3.3 Hourmeter Readings

This feature will display the recorded hours of use of the traction and pump control to the Dash Display each time the key switch is turned off.

Section 2.3.4 Battery Discharge Indication (BDI)

The latest in microprocessor technology is used to provide accurate battery state of charge information and to supply passive and active warning signals to the vehicle operator. Features and functions:

- Displays 100 to 0 percent charge.
- Display blinks with 20% charge. Disables pump circuit with 10% charge. Auto ranging for 36/48 volt operation. Adjustable for use on 24 to 80 volts.

Section 2.3.4.a Internal Resistance Compensation

This feature is used when the Battery Discharge Indicator is present. Adjustment of this function will improve the accuracy of the BDI.

Section 2.3.5 Handset

This is a multi-functional tool used with the LX, ZX, and SX Series GE solid state controls. The Handset consists of a Light Emitting Diode (LED) display and a keyboard for data entry. Note, for ordering purposes, a separate Handset part is required for SX controls.

Features and functions:

- Monitor existing system status codes for both traction and pump controls. Monitor intermittent random status codes.
- Monitor battery state of charge, if available.
- Monitor hourmeter reading on traction and pump controls. Monitor or adjust the control functions.

Section 2.3.6 RS 232 Communication Port

This serial communication port can be used with Interactive Custom Dash Displays to allow changes to vehicle operating parameters by the operator. Or, it can be used by service personnel to dump control operating information and settings into a personal computer program.

Section 2.3.6.a Interactive Dash Display Modes

The Interactive Custom Dash Display allows the operator to select the best vehicle performance for changing factory (task) conditions. There are four (4) "operator interaction modes" that can be selected by depressing a push button on the dash display.

From the Dash Display, the operator may select any of four pre-set interactive modes consisting of (4) Controlled Acceleration levels, (4) Field Weakening levels and (4) Speed Limits.

These interactive modes are "pre-set" using the Handset (Functions 48-63) or a personal computer (Functions 97-112). This feature allows the operator to select the best vehicle performance for changing factory (task) conditions.

Section 2.3.7 Circuit Board Coil Driver Modules

Coil drivers are internal to the control card, and are the power devices that operate the Line, 1A and SP contactor coils. On command from the control card, these drivers initiate opening and closing the contactor coils. All driver modules are equipped with reverse battery protection, such that, if the battery is connected incorrectly, the contactors can not be closed electrically.

Section 3.0 ORDERING INFORMATION, ELEMENTARY AND OUTLINE DRAWINGS

Section 3.1 Ordering Information for Separately Excited Controls

Example:

Part Number:	IC3645	SE	4	D	33	2	C3
Argument Number:	01	02	03	04	05	06	07

Argument 01: Basic Electric Vehicle Control Number

Argument 02: Control Type:
 SH = Separately Excited Control (Plugging)
 SR = Separately Excited Control (Regen to Zero)

Argument 03: Operating Voltage:

1 = 120 volts	5 = 36/48 volts
2 = 24 volts	6 = 24/36 volts
3 = 36 volts	7 = 72/80 volts
4 = 48 volts	

Argument 04: Package Size:

D = 6.86" X 6.67"
R = 6.86" X 8.15"
U = 8.66" X 8.13"
W = 8.66" X 10.83"

Argument 05: Armature Current
 (2 characters)

22 = 220 Amps
33 = 330 Amps
40 = 400 Amps

etc.

Argument 06: Field Current
 (1 character)

2 = 20 Amps
3 = 30 Amps
4 = 40 Amps

etc.

Argument 07: Customer / Revision

A1 = Customer A / Revision 1
B1 = Customer B / Revision 1

etc.

Section 3.2 Outline: SX-2 Package Size

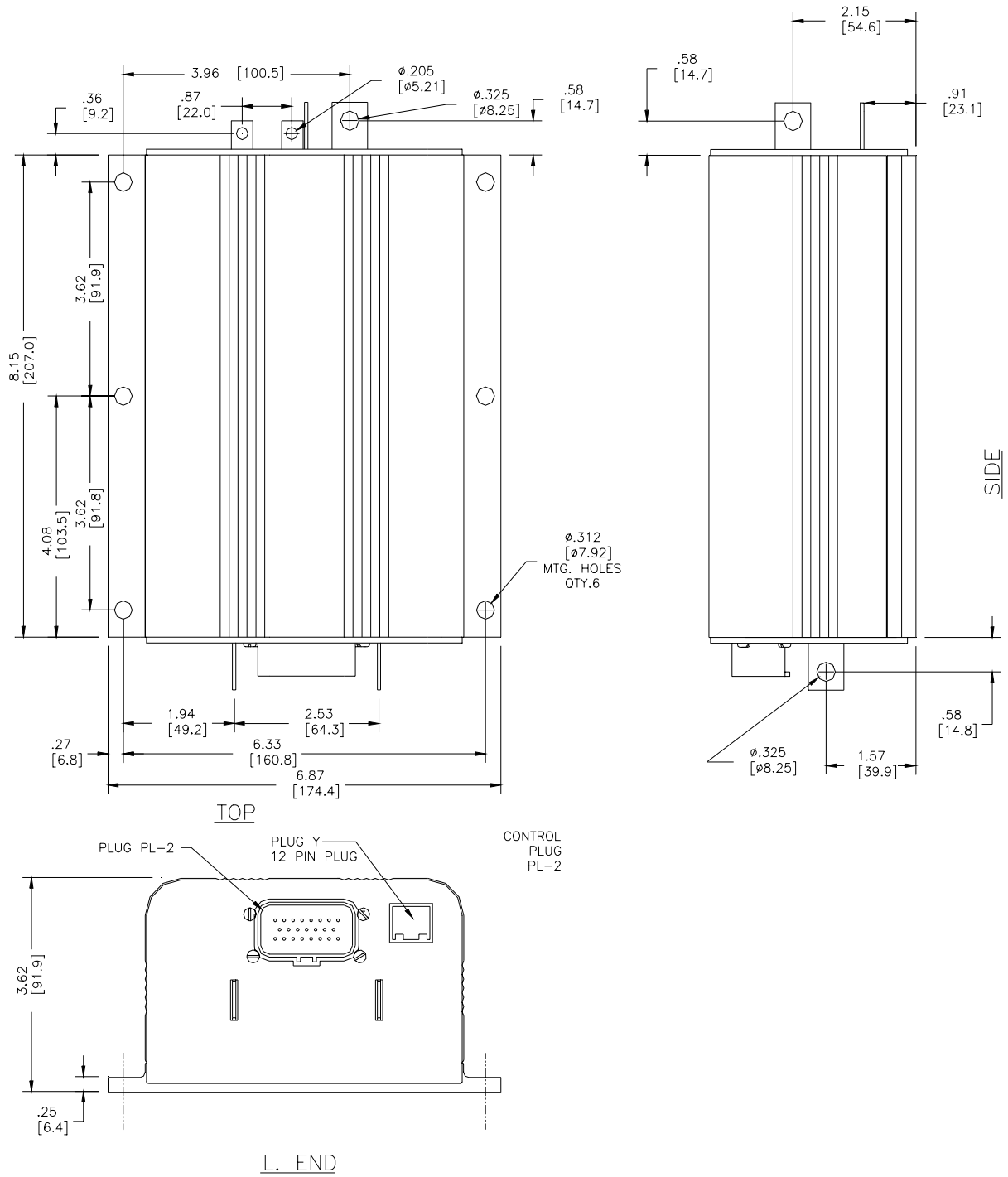

Section 3.3 Standard Dual Motor Proportioning Drive Elementary

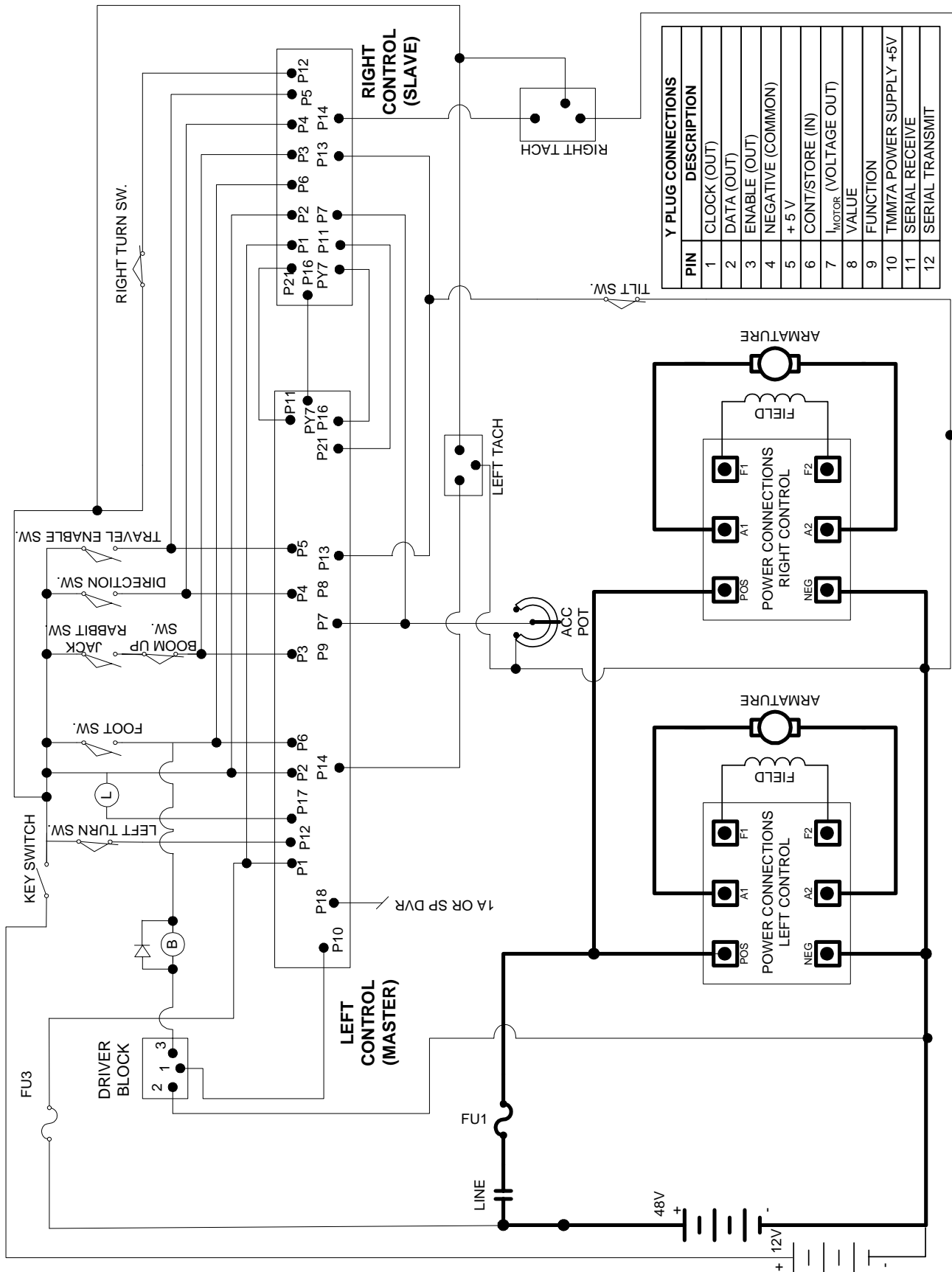

Section 3.4 Standard Dual Motor Proportioning Drive Input/Output List

Connections to Main Plug (23 Pin) and "Y" Plug (12 Pin)

STANDARD DUAL MOTOR PROPORTIONING MAIN PLUG INPUT/OUTPUT DESCRIPTION	
PIN	
1	BATTERY VOLTS FROM BATTERY
2	12 VOLTS FROM KEY
3	12 VOLTS FROM BOOM SWITCH
4	12 VOLTS FROM DIRECTIONAL SWITCH
5	12 VOLTS FROM TRAVEL ENABLE SWITCH
6	12 VOLTS FROM FOOT SWITCH
7	ACCELERATOR INPUT VOLTAGE SIGNAL
8	NEGATIVE
9	ACCELERATOR POT +5 VOLTS SUPPLY
10	BRAKE DRIVER SIGNAL
11	CROSS TALK SEND
12	TURN SWITCH
13	TILT SENSOR
14	TACHOMETER INPUT SIGNAL
15	TACHOMETER +12 VOLTS SUPPLY
16	MOTOR CURRENT COMPENSATION
17	LINE CONTACTOR DRIVER AND SUPPRESSION
18	N/A
19	N/A
20	N/A
21	CROSS TALK RECEIVE
22	SERIAL RECEIVE
23	SERIAL TRANSMIT
MOTOR TRACTION "Y" PLUG INPUT/OUTPUT DESCRIPTION	
PIN	
1	CLOCK (OUT) (DASH DISPLAY-4)
2	DATA (OUT) (DASH DISPLAY-3)
3	ENABLE (OUT) (DASH DISPLAY-1)
4	NEGATIVE (DASH DISPLAY-2)
5	+5V SUPPLY (DASH DISPLAY-5)
6	CONT/STORE (IN) (HANDSET)
7	MOTOR CURRENT
8	VALUE (TMMA-9)
9	FUNCTION (TMMA-7)
10	+5V SUPPLY (TMMA-13)
11	SERIAL RECEIVE
12	SERIAL TRANSMIT

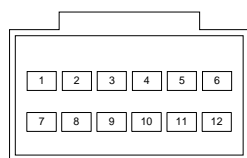

WIRE END VIEW "Y" PLUG

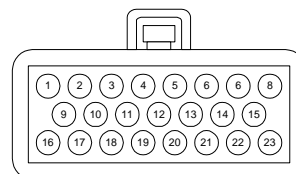

WIRE END VIEW - MAIN PLUG

Section 4.0 TROUBLESHOOTING AND DIAGNOSTIC STATUS CODES

Section 4.1 General Maintenance Instructions

The transistor control, like all electrical apparatus, does have some thermal losses. The semiconductor junctions have finite *temperature* limits, above which these devices may be damaged. For these reasons, normal maintenance should guard against any action which will expose the components to excessive heat and/or those conditions which will reduce the heat dissipating ability of the control, such as restricting air flow.

The following Do's and Don't's should be observed:

Any controls that will be applied in ambient temperatures over 100° F (40° C) should be brought to the attention of the vehicle manufacturer.

All external components having inductive coils must be filtered. Refer to vehicle manufacturer for specifications.

The wiring should not be directly steam cleaned. In dusty areas, blow low-pressure air over the control to remove dust. In oily or greasy areas, a mild solution of detergent or denatured alcohol can be used to wash the control, and then low-pressure air should be used to completely dry the control.

For the control to be most effective, it must be mounted against the frame of the vehicle. The metal vehicle frame, acting as an additional heat sink, will give improved vehicle performance by keeping the control package cooler. *Apply a thin layer of heat-transfer grease (such as Dow Corning 340) between the control heat sink and the vehicle frame.*

Control wire plugs and other exposed transistor control parts should be kept free of dirt and paint that might change the effective resistance between points.

CAUTION: The vehicle should not be plugged when the vehicle is jacked up and the drive wheels are in a free wheeling position. The higher motor speeds can create excessive voltages that can be harmful to the control.

Do not hipot (or megger) the control. Refer to control manufacturer before hipotting.

Use a lead-acid battery with the voltage and ampere hour rating specified for the vehicle. Follow normal battery maintenance procedures, recharging before 80 percent discharged with periodic equalizing charges.

Visual inspection of GE contactors contained in the traction and pump systems is recommended to occur during every

160 hours of vehicle operation. Inspection is recommended to verify that the contactors are not binding and that the tips are intact and free of contaminants.

GE does not recommend that any type of welding be performed on the vehicle after the installation of the control(s) in the vehicle. GE will not honor control failures during the warranty period when such failures are attributed to welding while the control is installed in the vehicle.

Section 4.2 Cable Routing and Separation

Electrical noise from cabling of various voltage levels can interfere with a microprocessor-based control system. To reduce this interference, GE recommends specific cable separation and routing practices, consistent with industry standards.

Section 4.2.1 Application Responsibility

The customer and customer's representative are responsible for the mechanical and environmental locations of cables. They are also responsible for applying the level rules and cabling practices defined in this section. To help ensure a lower cost, noise-free installation, GE recommends early planning of cable routing that complies with these level separation rules.

On new installations, sufficient space should be allowed to efficiently arrange mechanical and electrical equipment. On vehicle retrofits, level rules should be considered during the planning stages to help ensure correct application and a more trouble-free installation.

Section 4.2.2. Signal/Powerlevel Definitions

The signal/power carrying cables are categorized into four defining levels: low, high, medium power, and high power. Within those levels, signals can be further divided into classes.

Sections 4.2.2.a through 4.2.2.d define these levels and classes, with specific examples of each. Section 4.2.3 contains recommendations for separating the levels.

Section 4.2.2.a Low-Level Signals (Level L)

Low-level signals are designated as *level L*. These consist of:

- Analog signals 0 through ± 15 V
- Digital signals whose logic levels are less than 15 V DC
- 4 – 20 mA current loops
- DC busses less than 15 V and 250 mA

The following are specific examples of level L signals used in drive equipment cabling:

- Control common tie
- DC buses feeding sensitive analog or digital hardware

- All wiring connected to components associated with sensitive analog hardware with less than 5V signals (for example, potentiometers and tachometers)
- Digital tachometers and resolvers
- Dash display cabling
- RS-232 cabling

Note: Signal inputs to analog and digital blocks should be run as shielded twisted-pair (for example, inputs from tachometers, potentiometers, and dash displays).

Section 4.2.2.b High-Level Signals (Level H)

High-level signals are designated as *level H*. These signals consist of:

- Analog and digital signals greater than 15 V DC and less than 250 mA

For example, switch inputs connected to battery volts are examples of level H signals used in drive equipment cabling.

Section 4.2.2.c Medium-Power Signals (Level MP)

Medium power signals are designated as *level MP*. These signals consist of:

- DC switching signals greater than 15 V
- Signals with currents greater than 250 mA and less than 10A

The following are specific examples of level MP signals used in drive equipment cabling:

- DC busses less than 10 A
- Contactor coils less than 10 A
- Machine fields less than 10 A

Section 4.2.2.d High Power Signals (Level HP)

Power wiring is designated as *level HP*. This consists of DC buses and motor wiring with currents greater than 10 A. The following are specific examples of level HP signals used in drive equipment cabling:

- Motor armature loops
- DC outputs 10 A and above
- Motor field loops 10 A and above

Section 4.2.3. Cable Spacing Guidelines

Recommended spacing (or clearance) between cables (or wires) is dependent on the level of the wiring inside them. For correct level separation when installing cable, the customer must apply the **general guidelines** (section 4.2.3.a), outlined below.

Section 4.2.3.a General Cable Spacing

The following general practices should be used for *all levels* of cabling:

- All cables and wires of like signal levels and power levels must be grouped together.
- In general, different levels must run in separate wire bundles, as defined in the different classes, identified above. Intermixing cannot be allowed, unless noted by exception.
- Interconnecting wire runs should carry a level designation.
- If wires are the same level and same type signal, group those wires from one location to any other location together in multiconductor cables or bind them together with twine or zip-ties.
- When unlike signals must cross, cross them in 90° angles at a maximum spacing. Where it is not possible to maintain spacing, place a grounded steel barrier between unlike levels at the crossover point.

Section 4.2.4 Cabling for Vehicle Retrofits

Reducing electrical noise on vehicle retrofits requires careful planning. Lower and higher levels should never encircle each other or run parallel for long distances. It is practical to use existing wire runs or trays as long as the level spacing (see section 4.2.2) can be maintained for the full length of the run.

Existing cables are generally of high voltage potential and noise producing. Therefore, route levels L and H in a path separate from existing cables, whenever possible. For level L wiring, use barriers in existing wire runs to minimize noise potential.

Do not loop level L signal wires around level H, level MP, or HP wires.

Section 4.2.5 RF Interference

To prevent radio frequency (RF) interference, care should be taken in routing power cables in the vicinity of radio-controlled devices.

Section 4.2.6 Suppression

Unless specifically noted otherwise, suppression (for example, a snubber) is required on all inductive devices controlled by an output. This suppression minimizes noise and prevents damage caused by electrical surges.

Section 4.3 Recommended Lubrication of Pins and Sockets Prior to Installation

Beginning in January of 1999, GE will implement the addition of a lubricant to all connections using pins and sockets on EV100/EV200 and Gen II products. Any connection made by GE to the A, B, X, Y, or Z plugs will have the lubricant NYE 760G added to prevent fretting of these connections during vehicle operation.

Fretting occurs during microscopic movement at the contact points of the connection. This movement exposes the base metal of the connector pin which, when oxygen is present, allows oxidation to occur. Sufficient build up of the oxidation can cause intermittent contact and intermittent vehicle operation. This can occur at any similar type of connection, whether at the control or in any associated vehicle wiring, and the resultant intermittent contact can provide the same fault indication as actual component failure.

The addition of the NYE 760G lubricant will prevent the oxidation process by eliminating the access of oxygen to the contact point. GE recommends the addition of this lubricant to the 12 pin and 23 pin plugs of all new Gen II controls at the time of their installation into a vehicle.

When servicing existing vehicles exhibiting symptoms of intermittent mis-operation or shutdown by the GE control, GE recommends the addition of this lubricant to all 12 and 23 pin plugs, after proper cleaning of the connectors, as a preventative measure to insure fretting is not an issue before GE control replacement.

Section 4.4 General Troubleshooting Instructions

Trouble-shooting the SX family of controls should be quick and easy when following the instructions outlined in the following status code instruction sheets.

If mis-operation of the vehicle occurs, a status code will be displayed on the Dash Display (for vehicles equipped with a Dash Display) or made available by plugging a Handset into the plug "Y" location, and then reading the status code.

With the status code number, follow the procedures outlined in the status code instruction sheets to determine the problem.

Important Note: Due to the interaction of the logic card with all vehicle functions, almost any status code or control fault could be caused by the logic card. After all other status code procedures have been followed and no problem is found, the controller should then be replaced as the last option to correct the problem.

The same device designations have been maintained on different controls but the wire numbers may vary. Refer to

the elementary and wiring diagrams for your specific control. The wire numbers shown on the elementary diagram will have identical numbers on the corresponding wiring diagrams for a specific vehicle, but these numbers may be different from the numbers referenced in this publication.

WARNING: Before trouble-shooting, jack up the drive wheels, disconnect the battery and discharge the capacitors. Reconnect the battery as needed for specific checks. Capacitors should be discharged by connecting a 200 ohm 2 watt resistor between the positive and negative terminals on the control panel.

Check resistance on R x 1000 scale from frame to power and control terminals. A resistance of less than 20,000 ohms can cause misleading symptoms. Resistance less than 1000 ohms should be corrected first.

Before proceeding, visually check for loose wiring, mis-aligned linkage to the accelerator switch, signs of overheating of components, etc.

Tools and test equipment required are: clip leads, volt-ohm meter (20,000 ohms per volt) and basic hand tools.

Section 4.5 Traction Control Status Codes

TRACTION STATUS CODE	DESCRIPTION OF STATUS	CAUSE OF STATUS INDICATION
NONE	Segments do not illuminate on the Dash Display and/or the Handset.	No input voltage to the control card or the display unit.
MEMORY RECALL NO	CORRECTIVE ACTIONS	<u>TROUBLE-SHOOTING DIAGRAM</u>
Circuits valid for Traction Controller	<p><u>SYMPTOM</u> Display screen on Dash Display and/or Handset is blank.</p> <p><u>POSSIBLE CAUSE</u> Positive or negative control voltage is not present.</p> <ul style="list-style-type: none"> • Insure that the key switch is closed and voltage is present between P1 & battery negative (Power Terminal "NEG"). Also check for voltage between P2 and control negative. <p>Open circuit between control card Plug Y & the Dash Display or Handset.</p> <ul style="list-style-type: none"> • Check for an open circuit or loose connection going from the "Y" plug and the Dash Display or Handset. <p>Defective Dash Display or Handset.</p> <ul style="list-style-type: none"> • Replace Dash Display or Handset. 	

TRACTION STATUS CODE	DESCRIPTION OF STATUS	CAUSE OF STATUS INDICATION
-01	No foot switch or deadman switch input (no voltage to P6).	This status code will be displayed when P6 is less than 12% battery volts.
MEMORY RECALL NO	CORRECTIVE ACTIONS	<u>TROUBLE-SHOOTING DIAGRAM</u>
Circuits valid for Traction Controller	<p><u>SYMPTOM</u> Control will not operate.</p> <p><u>POSSIBLE CAUSE</u> Mis-adjusted or defective foot or deadman switch.</p> <ul style="list-style-type: none"> • Check to see that the foot switch closes properly. <p>Open circuit between battery positive and P6.</p> <ul style="list-style-type: none"> • Check for loose connections or broken wires: <ul style="list-style-type: none"> – Between the foot switch and P6 – Between the key switch and the battery positive side of the foot switch. – Between the foot switch and P2. • On vehicles without a foot/deadman switch, check for a loose connection or broken wire from P2 and/or P6. 	

TRACTION STATUS CODE	DESCRIPTION OF STATUS	CAUSE OF STATUS INDICATION
-02	Directional switch is closed on initial power up.	This status code will be displayed when P4 is greater than 12% of battery voltage at initial key switch on.
MEMORY RECALL NO	CORRECTIVE ACTIONS	TROUBLE-SHOOTING DIAGRAM
Circuits valid for Traction Controller	<p>SYMPTOM Control will not operate because of Static Return to Off (SRO) lock out.</p> <p>POSSIBLE CAUSE Forward directional switch is closed on initial start up (i.e. closure of battery, key switch or foot switch).</p> <ul style="list-style-type: none"> Return directional switch lever to neutral and then return lever to forward position. <p>Forward directional switch is welded closed or mis-adjusted to be held closed.</p> <ul style="list-style-type: none"> Replace or adjust directional switch to insure that it opens when the directional switch is returned to neutral. <p>Short circuit between P3 and P4.</p> <ul style="list-style-type: none"> Disconnect the wire from P4 and check for a short circuit between P3 and the wire that was connected to P4. <p>Defective control.</p> <ul style="list-style-type: none"> Replace the controller unit. 	

TRACTION STATUS CODE	DESCRIPTION OF STATUS	CAUSE OF STATUS INDICATION
-03	Travel enable switch is closed on initial power up.	This status code will be displayed when P5 is greater than 12% of battery voltage at initial key switch on.
MEMORY RECALL NO	CORRECTIVE ACTIONS	TROUBLE-SHOOTING DIAGRAM
Circuits valid for Traction Controller	<p>SYMPTOM Control will not operate because of Static Return to Off (SRO) lock out.</p> <p>POSSIBLE CAUSE Reverse directional switch is closed on initial start up (i.e. closure of battery, key switch or foot/deadman switch).</p> <ul style="list-style-type: none"> Return directional switch lever to neutral and then return lever to reverse position. <p>Reverse directional switch is welded closed or mis-adjusted to be held closed.</p> <ul style="list-style-type: none"> Replace or adjust directional switch to insure that it opens when the directional switch is returned to neutral. <p>Short circuit between P3 and P5.</p> <ul style="list-style-type: none"> Disconnect the wire from P5 and check for a short circuit between P3 and the wire that was connected to P5. <p>Defective control. Replace the controller unit.</p>	

TRACTION STATUS CODE	DESCRIPTION OF STATUS	CAUSE OF STATUS INDICATION
-05	Accelerator depressed without selecting travel enable switch.	This status code will be displayed when P4 and P5 are less than 12% of battery volts, and P7 is less than 2.5 volts.
MEMORY RECALL NO	CORRECTIVE ACTIONS	TROUBLE-SHOOTING DIAGRAM
Circuits valid for Traction Controller	<p>SYMPTOM Control will not operate.</p> <p>POSSIBLE CAUSE Accelerator pedal is depressed before closing forward or reverse directional switch.</p> <ul style="list-style-type: none"> Status code will disappear when directional switch is closed or when accelerator pedal is released. <p>Defective directional switch</p> <ul style="list-style-type: none"> Check forward or reverse switch to insure closure when direction is selected. <p>Open circuit between directional switch(es) and battery positive or between directional switch(es) and P4 or P5.</p> <ul style="list-style-type: none"> Check all control wires and connections shown in Trouble Shooting Diagram. 	

TRACTION STATUS CODE	DESCRIPTION OF STATUS	CAUSE OF STATUS INDICATION
-07	Accelerator input voltage too high on power up after initial key switch closure.	This status code will be displayed when the accelerator input voltage at P7 is higher than 3.7 volts, and travel enable switch is selected.
MEMORY RECALL NO	CORRECTIVE ACTIONS	TROUBLE-SHOOTING DIAGRAM
Circuits valid for Traction Controller	<p>SYMPTOM Control will not operate when accelerator pedal is depressed or status code -07 is displayed then disappears when the vehicle starts to accelerate.</p> <p>POSSIBLE CAUSE Accelerator input mis-adjusted or defective.</p> <ul style="list-style-type: none"> Input voltage at P7 should be less than 3.7 volts. Adjust or replace accelerator unit to insure that the voltage at P7 will vary from 3.5 volts to less than .5 volts when the pedal is depressed. <p>Open circuit between battery negative and P7 in accelerator input circuit.</p> <ul style="list-style-type: none"> Check for broken wires or loose connections or open potentiometer / voltage supply. <p>Short circuit from battery positive to wiring in accelerator input circuit.</p> <ul style="list-style-type: none"> Disconnect wire from P7 and measure voltage at wire to negative. Should be zero volts for potentiometer type and less than 3.7 volts for solid state type accelerator input. 	

TRACTION STATUS CODE	DESCRIPTION OF STATUS	CAUSE OF STATUS INDICATION
-08	Accelerator input voltage too low on power up after initial key switch closure.	This status code will be displayed when the accelerator input voltage at P7 is less than 3.0 volts, and any of the following connections are opened and closed: battery plug or key switch.
MEMORY RECALL NO	CORRECTIVE ACTIONS	<u>TROUBLE-SHOOTING DIAGRAM</u>
Circuits valid for Traction Controller	<p><u>SYMPTOM</u> Control will not operate.</p> <p><u>POSSIBLE CAUSE</u> Accelerator input mis-adjusted or defective.</p> <ul style="list-style-type: none"> Input voltage at P7 should be more than 3.0 volts. Adjust or replace accelerator unit to insure that the voltage at P7 is more than 3.0 volts before depressing pedal. <p>Short circuit between battery negative and TB1 in accelerator input circuit.</p> <ul style="list-style-type: none"> Disconnect wire from P7. Check for short circuit from wire to battery negative. Resistance should be greater than 4.7K ohms. <p>Defective control.</p> <ul style="list-style-type: none"> Disconnect wire from P7. Measure voltage from TB1 to negative. Voltage should be greater than 4.5 volts, if not, replace control. 	

TRACTION STATUS CODE	DESCRIPTION OF STATUS	CAUSE OF STATUS INDICATION
-09	The travel enable switch is open and the directional switch is closed.	This status code will be displayed when P5 is less than 12% of battery volts and P4 is greater than 12% of battery volts.
MEMORY RECALL NO	CORRECTIVE ACTIONS	<u>TROUBLE-SHOOTING DIAGRAM</u>
Circuits valid for Traction Controller	<p><u>SYMPTOM</u> Control will not operate.</p> <p><u>POSSIBLE CAUSE</u> Forward or reverse directional switch welded closed or mis-adjusted to be held closed.</p> <ul style="list-style-type: none"> Replace or adjust directional switches to insure that they open when directional switch is returned to neutral. <p>Short circuit between battery positive and P4 and/or P5.</p> <ul style="list-style-type: none"> Disconnect wires from P4 and P5 and check wire for short circuit to positive side of directional switch. <p>Defective Control</p> <ul style="list-style-type: none"> Disconnect wires and measure voltage at P4 and P5. Voltage should be less than 60% of battery volts. 	

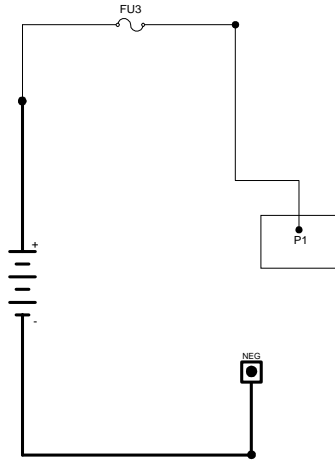
TRACTION STATUS CODE	DESCRIPTION OF STATUS	CAUSE OF STATUS INDICATION												
-15	Battery voltage is too low or control card is mis-adjusted.	This status code will be displayed when the battery volts are less than 1.95 volts per cell at initial key switch on. See table below.												
MEMORY RECALL NO	CORRECTIVE ACTIONS	TROUBLE-SHOOTING DIAGRAM												
Circuits valid for Traction Controller	<p>SYMPTOM Control will not operate.</p> <p>POSSIBLE CAUSE Discharged battery</p> <ul style="list-style-type: none"> Check battery for proper open circuit voltage as shown in "Trouble Shooting Diagram", charge battery, if required. <p>Defective battery</p> <ul style="list-style-type: none"> Check each battery cell for proper voltage (greater than 1.95 volts at cell). Replace or repair battery. <p>Incorrect control card adjustment.</p> <ul style="list-style-type: none"> Check Function 15 for proper adjustment for battery being used. See Handset instruction sheet for details. Adjust to proper settings. <p>Check "minimum" battery volts at P1 and NEG.</p>	 <table border="1" data-bbox="1247 529 1471 756"> <thead> <tr> <th>NOMINAL BATTERY VOLTAGE</th> <th>MINIMUM LIMIT VOLTS AT 1.95 VDC PER CELL</th> </tr> </thead> <tbody> <tr> <td>24</td> <td>23.4</td> </tr> <tr> <td>36</td> <td>35.1</td> </tr> <tr> <td>48</td> <td>46.8</td> </tr> <tr> <td>72</td> <td>70.2</td> </tr> <tr> <td>80</td> <td>78.0</td> </tr> </tbody> </table>	NOMINAL BATTERY VOLTAGE	MINIMUM LIMIT VOLTS AT 1.95 VDC PER CELL	24	23.4	36	35.1	48	46.8	72	70.2	80	78.0
	NOMINAL BATTERY VOLTAGE	MINIMUM LIMIT VOLTS AT 1.95 VDC PER CELL												
24	23.4													
36	35.1													
48	46.8													
72	70.2													
80	78.0													

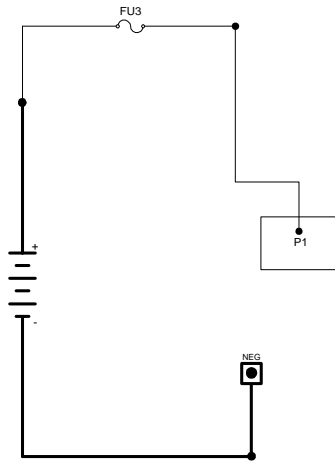
TRACTION STATUS CODE	DESCRIPTION OF STATUS	CAUSE OF STATUS INDICATION												
-16	Battery voltage is too high or control card is mis-adjusted.	This status code will be displayed when the battery volts are greater than 2.40 volts per cell at initial key switch on. See table below.												
MEMORY RECALL NO	CORRECTIVE ACTIONS	TROUBLE-SHOOTING DIAGRAM												
Circuits valid for Traction Controller	<p>SYMPTOM Control will not operate.</p> <p>POSSIBLE CAUSE Incorrect control card adjustment Check Function 15 for proper adjustment for battery being used. See Handset instructions for details. Adjust to proper setting.</p> <p>Battery over charged or incorrect battery used.</p> <ul style="list-style-type: none"> Check battery for proper open circuit voltage per table at right. If voltage is excessive, check battery charger for proper output voltage. <p>Check "maximum" battery volts at P1 and NEG.</p>	 <table border="1" data-bbox="1247 1358 1471 1585"> <thead> <tr> <th>NOMINAL BATTERY VOLTAGE</th> <th>MAXIMUM LIMIT VOLTS AT 2.40 VDC PER CELL</th> </tr> </thead> <tbody> <tr> <td>24</td> <td>28.8</td> </tr> <tr> <td>36</td> <td>43.2</td> </tr> <tr> <td>48</td> <td>57.6</td> </tr> <tr> <td>72</td> <td>86.4</td> </tr> <tr> <td>80</td> <td>96.0</td> </tr> </tbody> </table>	NOMINAL BATTERY VOLTAGE	MAXIMUM LIMIT VOLTS AT 2.40 VDC PER CELL	24	28.8	36	43.2	48	57.6	72	86.4	80	96.0
	NOMINAL BATTERY VOLTAGE	MAXIMUM LIMIT VOLTS AT 2.40 VDC PER CELL												
24	28.8													
36	43.2													
48	57.6													
72	86.4													
80	96.0													

TRACTION STATUS CODE	DESCRIPTION OF STATUS	CAUSE OF STATUS INDICATION
-23	Motor field current is high on start up in the reverse direction.	This status code will be displayed when the current draw in the motor field is too high at start up in the reverse direction.
MEMORY RECALL NO	CORRECTIVE ACTIONS	<u>TROUBLE-SHOOTING DIAGRAM</u>
Circuits valid for Traction Controller	<p><u>SYMPTOM</u> Control will not operate.</p> <p><u>POSSIBLE CAUSE</u> Defective control.</p> <ul style="list-style-type: none"> • Replace controller unit. 	NO GRAPHIC FOR THIS STATUS CODE

TRACTION STATUS CODE	DESCRIPTION OF STATUS	CAUSE OF STATUS INDICATION
-24	Motor field current is high on start up in the forward direction.	This status code will be displayed when the current draw in the motor field is too high at start up in the forward direction.
MEMORY RECALL NO	CORRECTIVE ACTIONS	<u>TROUBLE-SHOOTING DIAGRAM</u>
Circuits valid for Traction Controller	<p><u>SYMPTOM</u> Control will not operate.</p> <p><u>POSSIBLE CAUSE</u> Defective control.</p> <ul style="list-style-type: none"> • Replace controller unit. 	NO GRAPHIC FOR THIS STATUS CODE

TRACTION STATUS CODE	DESCRIPTION OF STATUS	CAUSE OF STATUS INDICATION
-27	Power supply is less than 10 Volts DC.	This status code will be displayed when the power supply is less than 10 volts.
MEMORY RECALL YES	CORRECTIVE ACTIONS	<u>TROUBLE-SHOOTING DIAGRAM</u>
Circuits valid for Traction Controller	<p><u>SYMPTOM</u> Line contactor opens and closes, then can only be closed by opening and closing the key switch.</p> <p><u>POSSIBLE CAUSE</u> Discharged Battery</p> <ul style="list-style-type: none"> • Check battery to insure proper state of charge. Voltage may be dropping below 10 Volts DC under load. <p>Loose connection at P1.</p> <ul style="list-style-type: none"> • Insure that the wire connection at P1 is tight. <p>Defective control.</p> <ul style="list-style-type: none"> • Replace controller unit. 	

TRACTION STATUS CODE	DESCRIPTION OF STATUS	CAUSE OF STATUS INDICATION
-41	Open thermal protector (TP) or transistor over temperature.	This status code will be displayed when the voltage at the thermal protector is too high.
MEMORY RECALL YES	CORRECTIVE ACTIONS	<u>TROUBLE-SHOOTING DIAGRAM</u>
Circuits valid for Traction Controller	<p><u>SYMPTOM</u> Reduced or no power to traction motor in control range.</p> <p><u>POSSIBLE CAUSE</u> Control is in thermal cut-back.</p> <ul style="list-style-type: none"> • Allow control to cool, status code should disappear. <p>Defective control.</p> <ul style="list-style-type: none"> • Replace controller unit. 	<p style="text-align: center;">NO GRAPHIC FOR THIS STATUS CODE</p>

TRACTION STATUS CODE	DESCRIPTION OF STATUS	CAUSE OF STATUS INDICATION
-42	Motor armature offset voltage is too high.	This status code will be displayed when the voltage at the current sensor input is greater than 2.6 volts with no current flowing in the motor circuit.
MEMORY RECALL NO	CORRECTIVE ACTIONS	<u>TROUBLE-SHOOTING DIAGRAM</u>
Circuits valid for Traction Controller	<p><u>SYMPTOM</u> Control will not operate.</p> <p><u>POSSIBLE CAUSE</u> Defective control.</p> <ul style="list-style-type: none"> • Replace controller unit. 	NO GRAPHIC FOR THIS STATUS CODE

TRACTION STATUS CODE	DESCRIPTION OF STATUS	CAUSE OF STATUS INDICATION
-43	Motor armature offset voltage is too low.	This status code will be displayed when the voltage at the current sensor input is less than 2.4 volts with no current flowing in the motor circuit.
MEMORY RECALL NO	CORRECTIVE ACTIONS	<u>TROUBLE-SHOOTING DIAGRAM</u>
Circuits valid for Traction Controller	<p><u>SYMPTOM</u> Control will not operate.</p> <p><u>POSSIBLE CAUSE</u> Defective control.</p> <ul style="list-style-type: none"> • Replace controller unit. 	NO GRAPHIC FOR THIS STATUS CODE

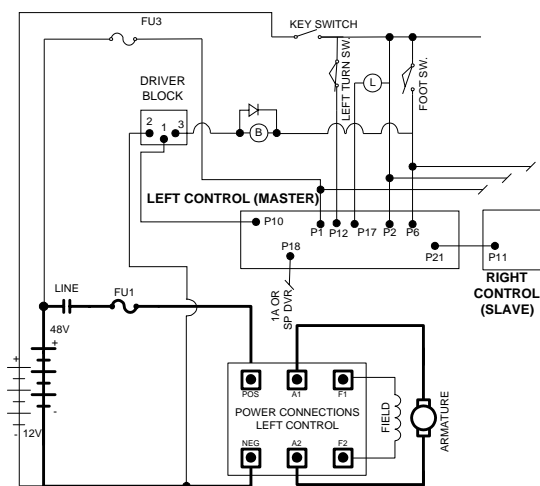
TRACTION STATUS CODE	DESCRIPTION OF STATUS	CAUSE OF STATUS INDICATION
-44	Armature transistor did not turn off properly.	This status code will be displayed when, during control operation, the armature transistor fails to turn off. This will result in a PMT condition.
MEMORY RECALL YES	CORRECTIVE ACTIONS	<u>TROUBLE-SHOOTING DIAGRAM</u> 
Circuits valid for Traction Controller	<p><u>SYMPTOM</u> Line contactor opens and closes, then can only be closed by opening and closing the key switch.</p> <p><u>POSSIBLE CAUSE</u> Defective control.</p> <ul style="list-style-type: none"> • Replace controller unit. 	

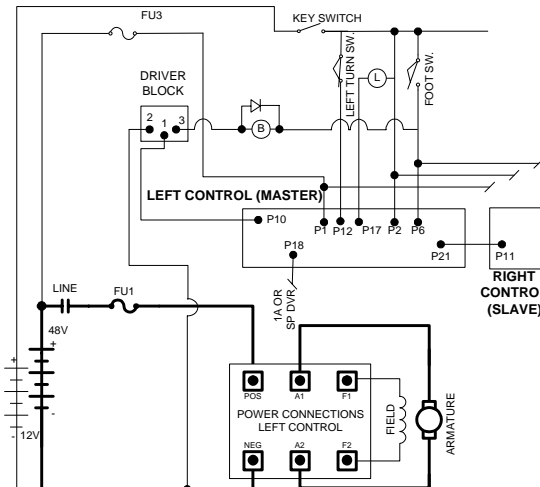
TRACTION STATUS CODE	DESCRIPTION OF STATUS	CAUSE OF STATUS INDICATION
-45	Armature transistor did not turn on properly.	This status code will be displayed when, during control operation, the armature transistor fails to turn on properly. This will result in a PMT condition.
MEMORY RECALL YES	CORRECTIVE ACTIONS	<u>TROUBLE-SHOOTING DIAGRAM</u> 
Circuits valid for Traction Controller	<p><u>SYMPTOM</u> Line contactor open and closes, then can only be closed by opening and closing the key switch.</p> <p><u>POSSIBLE CAUSE</u> Defective control.</p> <ul style="list-style-type: none"> • Replace controller unit. 	

TRACTION STATUS CODE	DESCRIPTION OF STATUS	CAUSE OF STATUS INDICATION
-46	"Look Ahead" test for A2 volts less than 12% of battery volts.	This status code will be displayed when the voltage at A2 is less than 12% of battery volts.
MEMORY RECALL NO	CORRECTIVE ACTIONS	<u>TROUBLE-SHOOTING DIAGRAM</u>
Circuits valid for Traction Controller	<p><u>SYMPTOM</u> Line contactor will not pick up.</p> <p><u>POSSIBLE CAUSE</u> Check for short circuit from the motor armature to the frame of the vehicle.</p> <p>Defective control.</p> <ul style="list-style-type: none"> • Replace controller unit. 	

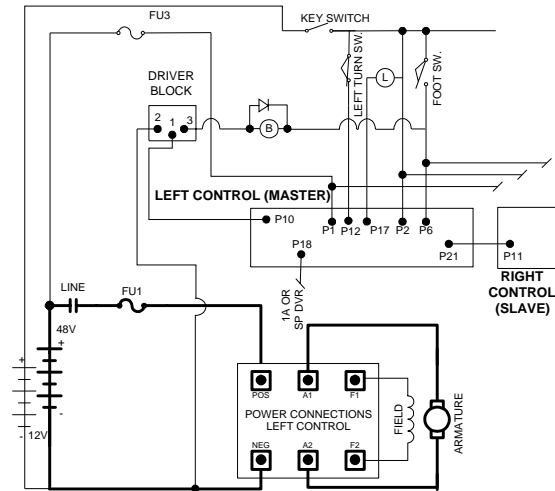

TRACTION STATUS CODE	DESCRIPTION OF STATUS	CAUSE OF STATUS INDICATION
-47	The PMT enable signal from the opposite control dropped below 5V during motoring.	This status code will be displayed when the voltage at PL2-21 drops below 5V during motoring.
MEMORY RECALL NO	CORRECTIVE ACTIONS	<u>TROUBLE-SHOOTING DIAGRAM</u>
Circuits valid for Traction Controller	<p><u>SYMPTOM</u> Control will not operate.</p> <p><u>POSSIBLE CAUSE</u> Auxiliary control shut down. Check auxiliary control for stored faults.</p> <p>Verify the connection between the master control P21 and the auxiliary/slave control P11.</p>	

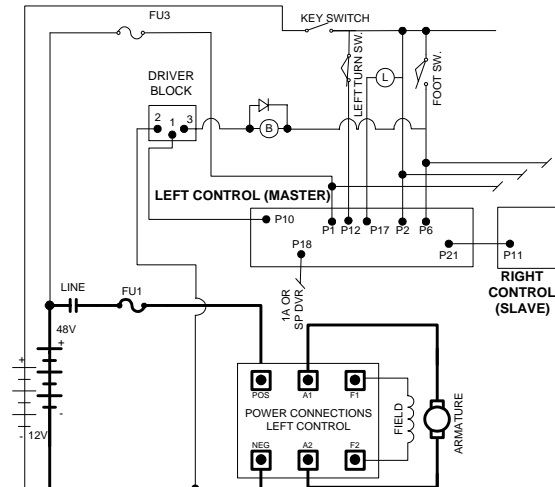

TRACTION STATUS CODE	DESCRIPTION OF STATUS	CAUSE OF STATUS INDICATION
-49	Motor field current is too low during the run mode.	This status code will be displayed when the current draw in the motor field is too low during the run mode.
MEMORY RECALL NO	CORRECTIVE ACTIONS	<u>TROUBLE-SHOOTING DIAGRAM</u>
Circuits valid for Traction Controller	<p><u>SYMPTOM</u> Control will not operate.</p> <p><u>POSSIBLE CAUSE</u> Defective control.</p> <ul style="list-style-type: none"> • Replace controller unit. 	<p>NO GRAPHIC FOR THIS STATUS CODE</p>

TRACTION STATUS CODE	DESCRIPTION OF STATUS	CAUSE OF STATUS INDICATION
-51	Capacitor volts are low before the line contactor closes.	This status code will be displayed during "key on" when the capacitor volts is less than 85% of battery volts at initial key switch on.
MEMORY RECALL NO	CORRECTIVE ACTIONS	<u>TROUBLE-SHOOTING DIAGRAM</u>
Circuits valid for Traction Controller	<p><u>SYMPTOM</u> Line contactor does not close when capacitor does not precharge.</p> <p><u>POSSIBLE CAUSE</u> Defective control fuse.</p> <ul style="list-style-type: none"> • Check control fuse for open circuit. Replace fuse, if necessary. <p>Defective control.</p> <ul style="list-style-type: none"> • Replace controller unit. 	<p>The diagram illustrates the electrical circuit for the traction controller. It shows a 48V line input passing through a fuse (FU3) to a key switch. The key switch is connected to a driver block and a left turn switch. The driver block has three terminals (2, 1, 3) connected to the left control (master) unit. The left control unit is connected to a 1A or SPD fuse, which then branches to the field and armature of the motor. The right control (slave) unit is also shown, connected to the motor's field and armature. A 12V battery is connected to the motor's field and armature. The diagram also shows a foot switch connected to the key switch.</p>

TRACTION STATUS CODE	DESCRIPTION OF STATUS	CAUSE OF STATUS INDICATION
-57	Controller "motor current sensor" input too low during running.	This status code will be displayed when the voltage input from the current sensor is too low during running.
MEMORY RECALL YES	CORRECTIVE ACTIONS	<u>TROUBLE-SHOOTING DIAGRAM</u>
Circuits valid for Traction Controller	<p><u>SYMPTOM</u> Control will not operate.</p> <p><u>POSSIBLE CAUSE</u> Defective control.</p> <ul style="list-style-type: none"> • Replace controller unit. 	<p>NO GRAPHIC FOR THIS STATUS CODE</p>

TRACTION STATUS CODE	DESCRIPTION OF STATUS	CAUSE OF STATUS INDICATION
-68	The PMT enable signal from the opposite control (from the one displaying the -68 fault code) drops below 5V .	This status code will be displayed when the voltage at PL21 drops below 5V.
MEMORY RECALL YES	CORRECTIVE ACTIONS	<u>TROUBLE-SHOOTING DIAGRAM</u>
Circuits valid for Traction Controller	<p><u>SYMPTOM</u> Control will not operate.</p> <p><u>POSSIBLE CAUSE</u></p> <ul style="list-style-type: none"> • Auxiliary control shut down. Check Auxiliary control for stored faults. • Verify the connection between the master control P21 and the auxiliary/slave control P11. 	<p>The diagram illustrates the electrical circuit for the traction controller. It shows a 48V power source connected to a fuse (FU1) and a 1A or SP DWR. The circuit includes a driver block with terminals 1, 2, and 3, and a key switch. The left control (master) is connected to the driver block and has terminals P1, P2, P6, P10, P12, P17, and P18. The right control (slave) has terminals P11 and P21. A field winding and armature are connected to the circuit. A 12V battery is also shown connected to the negative terminal of the 48V source.</p>

TRACTION STATUS CODE	DESCRIPTION OF STATUS	CAUSE OF STATUS INDICATION								
-76	Capacitor (1C) voltage too high.	This status code will be displayed when the voltage on the capacitor goes above limit voltage* during the regenerative braking cycle.								
MEMORY RECALL YES	CORRECTIVE ACTIONS	TROUBLE-SHOOTING DIAGRAM								
Circuits valid for Traction Controller	<p>SYMPTOM Line contactor opens and closes, then opens and can only close by opening and closing the key switch.</p> <p>POSSIBLE CAUSE</p> <ul style="list-style-type: none"> • Unplugging the battery connector during regenerative braking. • Line contactor bouncing open during regen. • Main power fuse opening during regen. • Intermittent battery plug connection. <p>* Limit Voltage:</p> <table border="1"> <thead> <tr> <th>Limit</th> <th>Battery Voltage</th> </tr> </thead> <tbody> <tr> <td>50V</td> <td>36V</td> </tr> <tr> <td>70V</td> <td>48V</td> </tr> <tr> <td>96V</td> <td>72//80V</td> </tr> </tbody> </table>	Limit	Battery Voltage	50V	36V	70V	48V	96V	72//80V	
Limit	Battery Voltage									
50V	36V									
70V	48V									
96V	72//80V									

TRACTION STATUS CODE	DESCRIPTION OF STATUS	CAUSE OF STATUS INDICATION
-77	Motor current is detected during regenerative braking.	This status code will be displayed when motoring current is detected during the regen braking cycle.
MEMORY RECALL YES	CORRECTIVE ACTIONS	TROUBLE-SHOOTING DIAGRAM
Circuits valid for Traction Controller	<p>SYMPTOM Line contactor opens and closes, then opens and can only close by opening and closing the key switch.</p> <p>POSSIBLE CAUSE Defective control.</p> <ul style="list-style-type: none"> • Replace controller unit 	

TRACTION STATUS CODE	DESCRIPTION OF STATUS	CAUSE OF STATUS INDICATION
-81	The input from the tach sensor has been lost or the motor has stalled.	This status code will be displayed when the control is not seeing any tach pulses.
MEMORY RECALL YES	CORRECTIVE ACTIONS	<u>TROUBLE-SHOOTING DIAGRAM</u>
Circuits valid for Traction Controller	<p><u>SYMPTOM</u> Control will not operate.</p> <p><u>POSSIBLE CAUSE</u> Bad tachometer</p> <ul style="list-style-type: none"> • Replace tachometer <p>Lost wire from tachometer.</p> <ul style="list-style-type: none"> • Verify tach connections. <p>Motor has stalled.</p> <p>Defective control.</p> <ul style="list-style-type: none"> • Replace controller unit 	<p>The diagram illustrates the electrical circuit for the traction controller. It shows a 48V power source connected through a fuse (FU1) to a '1A OR SP DIVR.' (1A or speed divider). The circuit branches into two main sections: the 'LEFT CONTROL (MASTER)' and the 'RIGHT CONTROL (SLAVE)'. The left control section includes a 'DRIVER BLOCK' with terminals 1, 2, and 3, and a tachometer (TACH) connected to terminal 1. The right control section includes a 'KEY SWITCH' and a 'FOOT SW.' (foot switch). The motor is connected to the controls, with a 'FIELD' winding and an 'ARMATURE' winding. The diagram also shows various connection points labeled P1 through P21, including P10, P12, P17, P2, P6, P18, and P21. A 12V battery is shown at the bottom left, connected to the 'NEG' terminal of the motor's power connections.</p>

Section 5.0 SX FAMILY GE HANDSET INSTRUCTIONS

Section 5.1 General Features

The GE Handset is a multi-functional tool to be used with the LX, ZX, and SX Series GE solid-state controls. The Handset consists of a Light Emitting Diode (LED) display and a keyboard for data entry. *Note: A different handset cord is required for use with SX controls than that used with LX and ZX controls.*

Section 5.2 Purpose / Setup Functions

The purpose of the Handset is to allow authorized personnel to perform the following functions of the SX family of Controls:

- Monitor existing system fault codes
- Monitor intermittent random fault codes
- Monitor battery state of charge on systems with BDI
- Monitor hourmeter reading
- Monitor or adjust the following control functions:
 - Creep speed
 - Armature Controlled Acceleration and 1A Time
 - Regenerative Braking Current Limit and Disable
 - Armature and Field Current Limit
 - Plugging Distance (Current)
 - Pedal Position Plug Range or Disable
 - 1A Drop Out Current or Disable
 - Speed Limit Points
 - Truck Management Fault Speed Limit
 - Internal Resistance Compensation for Battery State of Charge Indication
 - Battery Voltage (36/48 volts is auto ranging)
 - Selection of Card Operation Type.

Warning: Before connecting or disconnecting the Handset tool, turn off the key switch, unplug the battery and jack up the drive wheels of the vehicle.

At the transistor control traction card, unplug the "Y plug" if the dash display is in use, and plug in the Handset to the plug location "Y" on the control card. After installing the Handset tool, plug the battery in and turn the key switch on. The chart at the right details the start-up display sequence that will occur.

Note: The dash display must be disconnected when the Handset is plugged in, or the control power supply will be overloaded.

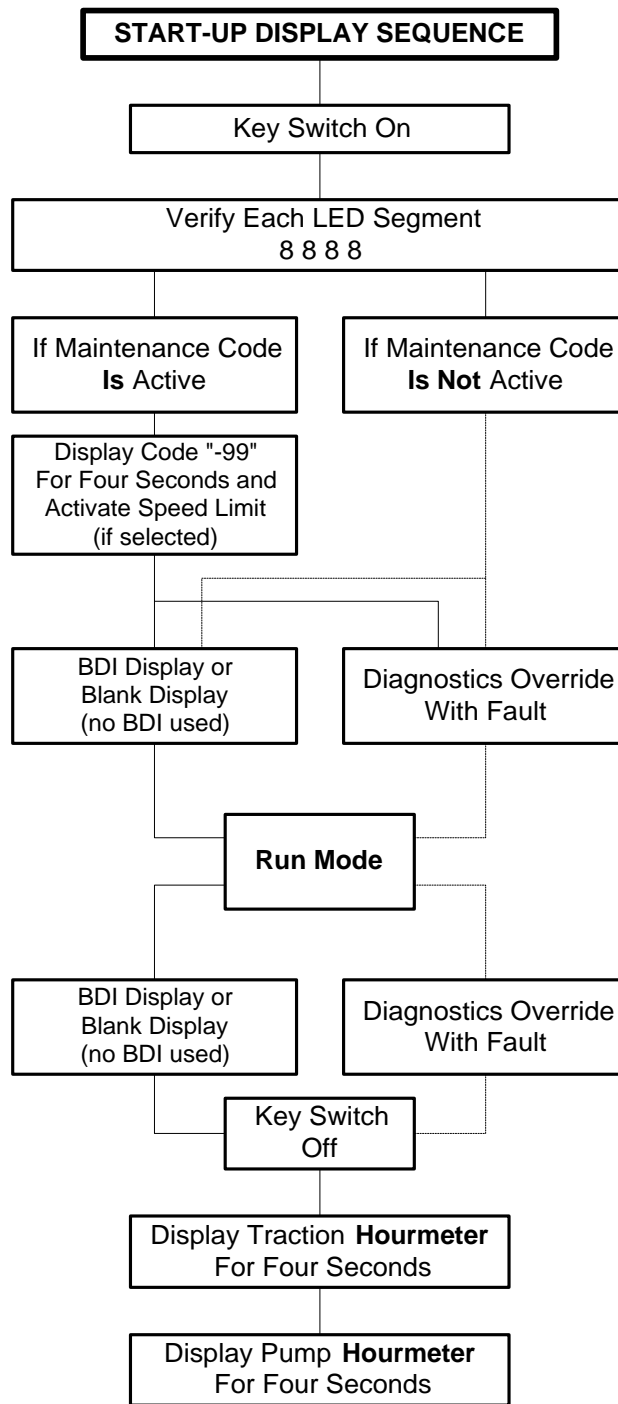

Warning: Before making any adjustments to the control, you must consult the operating and maintenance instructions supplied by the vehicle manufacturer. Failure to follow proper set up instructions could result in mis-operation or damage to the control system.

Section 5.3 Setup Function Procedures

With the Handset connected, hold down the **CONT** key and turn on the key switch. This will place you in the setup mode, ready to monitor or adjust control function settings.

NOTE: The term "Push" means to depress key for approximately one second.

Section 5.3.1 Setup Mode

SET-UP MODE		
ACTION	DISPLAY SHOWS	REMARKS
Hold Down CONT And Turn On Key	8 8 8 8	Segment Check Displayed
Push Function Number	U 0 0 5	Selected Function No. Is Displayed
After One Second Time Delay	0 8 5	Stored Value For The Function Is Displayed
Push CONT	0 8 5	Display Value Will Blink
Change Value with Adjustment Knob	1 2 5	Value Changes While Blinking
Push STORE	1 2 5	New Value Stored And Blinking Stops
Push ESC	8 8 8 8	Segment Check Displayed

At this point, another function can be monitored/changed by pushing another function number, or the vehicle can be placed in the run mode by holding the **ESC** key down for one second or longer. The display will return to either the diagnostics mode, the BDI display, or a blank display (if BDI is not used and there are no fault codes). The vehicle can now be operated with the Handset connected or the Handset can be disconnected before operation.

NOTE: You can return to the segment check mode at any time, by holding down the **ESC** key until 8888 appears in the display.

Section 5.3.2 Status Code Scrolling

The SX family of controllers furnishes a function register that contains the last 16 "stored status codes" that shut down vehicle operation (a PMT type fault that is reset by cycling the key switch) and the battery state of charge

reading at the time the fault occurred. The first of the 16 status codes will be overwritten each time a new status code occurs. This stored status code register can be cleared from memory by using the Handset.

ACCESSING STORED STATUS CODES WITH GE HANDSET

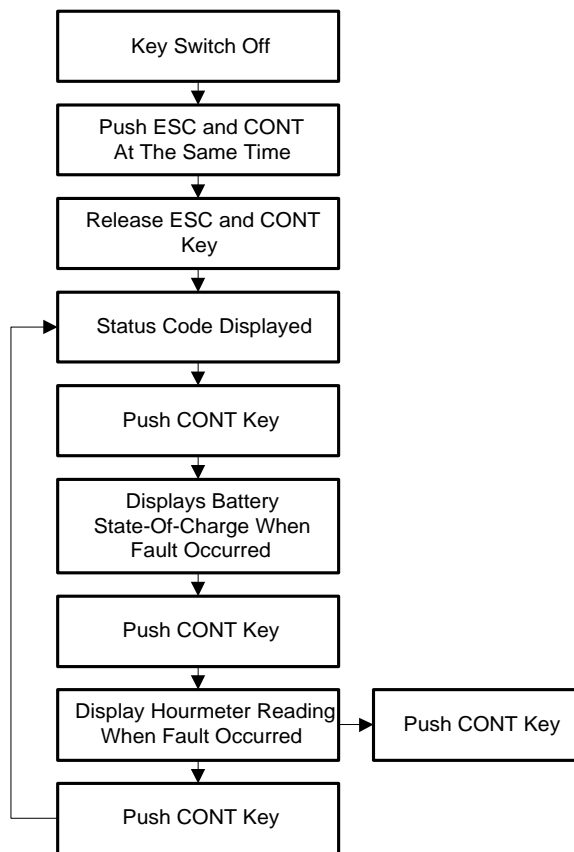

Section 5.3.3 SX Family Handset, Plug Connections and Outline Drawing

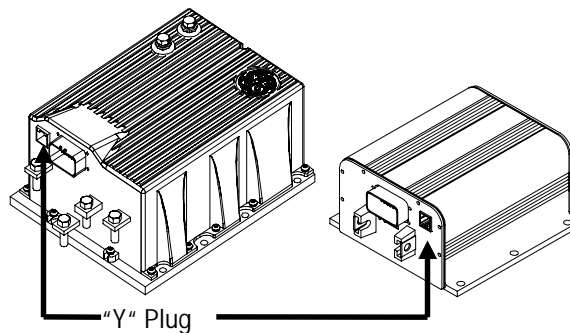

Handset Cable Part Number - 328A1550ATP1 (12 pin plug)
Handset Part Number - IC3645LXHS1EC2 (12 pin plug)
(includes handset, cable and case)

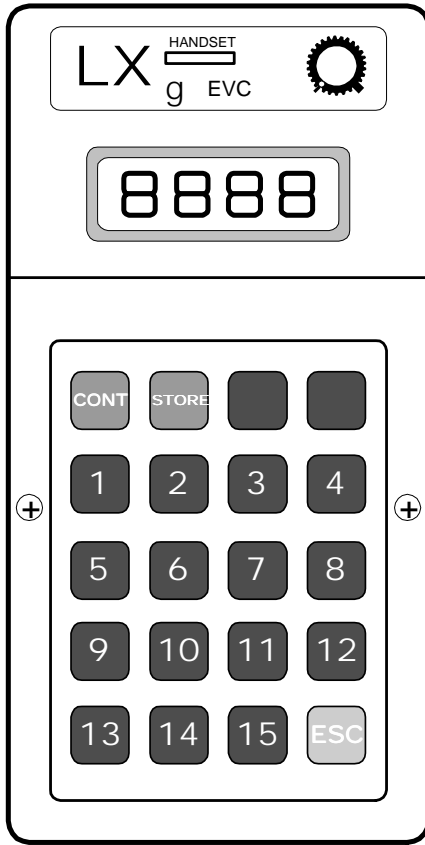

Section 5.4 Setup Functions for Traction Controller

FUNCTION 1 TACHOMETER SAMPLE RATE

This function allows for the adjustment of the rate at which the tachometer output is sampled by the control.

Range 0 to 1.275 seconds
Set 0 to 255
Resolution .005 seconds per set unit
Example Setting of 20 = 0.1 second

FUNCTION 2 CREEP SPEED (Push 2)

This function allows for the adjustment of the creep speed of the vehicle. Creep speed can be adjusted when an accelerator input voltage between 3.9 and 3.3 volts or an accelerator ohm input between 6.0 K and 4.0K ohms is provided.

Range 2% to 15% on time
Set 0 to 255
Resolution 0.05% per set unit
Example: Setting of 20 = 3% on time

Important Note: The function is used to optimize motor and control performance and this setting will be determined by

GE and OEM engineers at the time of vehicle development. This setting must not be changed by field personnel without the permission of the OEM.

FUNCTION 3 ARMATURE CONTROLLED ACCELERATION IN HIGH SPEED MODE (Push 3)

This function allows for the adjustment of the rate of time it takes for the control to accelerate to 100% applied battery voltage to the motor on hard acceleration in high speed mode.

Range 0.1 to 25.5 seconds
Set 1 to 255
Resolution 0.1 seconds per set unit
Example: Setting of 20 = 2.0 seconds
C/A = 2.2 seconds

FUNCTION 4 ARMATURE CURRENT LIMIT (Push 4)

This function allows for the adjustment of the armature current limit of the control. The rating of the control will determine the range of adjustment for this function. Please refer to the operating instructions and current limit curves for the control used in specific vehicle.

Range See control C/L curves
Set 0 to 255
Example: 0 = min. current,
255 = max. current

FUNCTION 5 PLUGGING CURRENT LIMIT (Push 5)

This function allows for the adjustment of the plugging distance of the vehicle. The larger the current setting, the shorter the stopping distance.

Min	Max	Set	Resolution Per unit value	Example If set at 20
26	226	0 to 255	0.78 amps	41.6 amps
55	455	0 to 255	1.57 amps	86.4 amps
55	655	0 to 255	2.35 amps	102 amps

Important Note: The function is used to optimize motor and control performance and this setting will be determined by GE and OEM engineers at the time of vehicle development. This setting must not be changed by field personnel without the permission of the OEM.

**FUNCTION 6 ARMATURE CONTROLLED
 ACCELERATION IN LOW SPEED MODE
 (Push 6)**

This function allows for the adjustment of the rate of time it takes for the control to accelerate to 100% applied battery voltage to the motor on hard acceleration in low speed mode.

Range 0.1 to 25.5 seconds
 Set 1 to 255
 Resolution 0.1 seconds per set unit
 Example: Setting of 20 = 2.0 seconds
 C/A = 2.2 seconds

**FUNCTION 7 MIN. FIELD CURRENT
 (Push 7)**

This function allows the adjustment of the field weakening level in order to set the top speed of the motor.

Min	Max	Set	Resolution Per unit value	Example If set at 71
0	20	51 to 176	0.16 amps	3.2 amps
0	30	51 to 255	0.16 amps	3.2 amps
0	40	51 to 255	0.185 amps	3.7 amps
0	50	51 to 210	0.314 amps	6.28 amps
0	60	51 to 255	0.314 amps	6.28 amps

Important Note: The function is used to optimize motor and control performance and this setting will be determined by GE and OEM engineers at the time of vehicle development. This setting must not be changed by field personnel without the permission of the OEM.

**FUNCTION 8 MAX FIELD CURRENT
 (Push 8)**

This function allows for the adjustment of the maximum field current in order to obtain the maximum torque of the motor.

Min	Max	Set	Resolution Per unit value	Example If set at 71
0	20	51 to 176	0.16 amps	3.2 amps
0	30	51 to 255	0.16 amps	3.2 amps
0	40	51 to 255	0.185 amps	3.7 amps
0	50	51 to 210	0.314 amps	6.28 amps
0	60	51 to 255	0.314 amps	6.28 amps

Important Note: The function is used to optimize motor and control performance and this setting will be determined by GE and OEM engineers at the time of vehicle development. This setting must not be changed by field personnel without the permission of the OEM.

**FUNCTION 9 REGEN BRAKING CURRENT LIMIT
 (Push 9)**

This function allows for the adjustment of the regen braking current limit.

Min	Max	Set	Resolution Per unit value	Example If set at 20
32	240	0 to 255	0.93 amps	50.6 amps
52	468	0 to 255	1.63 amps	84.6 amps
184	600	0 to 255	1.63 amps	216.6 amps

**FUNCTION 10 MAX FIELD CURRENT FOR REGEN
 (Push 10)**

This function allows for the adjustment of the maximum field current to be used during the regen braking mode.

Min	Max	Set	Resolution Per unit value	Example If set at 71
0	20	51 to 176	0.16 amps	3.2 amps
0	30	51 to 255	0.16 amps	3.2 amps
0	40	51 to 255	0.185 amps	3.7 amps
0	50	51 to 210	0.314 amps	6.28 amps
0	60	51 to 255	0.314 amps	6.28 amps

Important Note: The function is used to optimize motor and control performance and this setting will be determined by GE and OEM engineers at the time of vehicle development. This setting must not be changed by field personnel without the permission of the OEM.

**FUNCTION 11 "LOW SPEED" SPEED LIMIT
 (Push 11)**

This function allows for the adjustment of the speed limit when the jack rabbit is not selected or the boom is raised.

Range 0 to 20
 Set 0 to 20
 Resolution 1 pulse per sample
 Example: Setting of 5 = 5 pulses per sample rate

**FUNCTION 12 "HIGH SPEED" SPEED LIMIT
 (Push 12)**

This function is operates in the same way as Function 11, except that it is activated when the jack rabbit is selected or the boom is lowered.

FUNCTION 13 FIELD RAMP UP RATE WHILE IN REGENERATIVE BRAKING MODE (Push 13)

Important Note: This function is used to optimize motor and control performance and this setting will be determined by GE and OEM engineers at the time of vehicle development. This setting must not be changed by field personnel without the permission of the OEM.

FUNCTION 14 INTERNAL RESISTANCE COMPENSATION (Push 14)

This function is used when the Battery Discharge Indicator is present. Adjustment of this function will improve the accuracy of the BDI. In order to determine this setting, the voltage drop of the battery under load must first be calculated by the following method:

- Record open circuit voltage (V_0) by measuring the voltage at the control positive and negative power terminals.
- Load the traction motor to 100 amps in 1A and record the voltage (V_L) at the control positive and negative power terminals.
- Calculate voltage drop (V_{Drop}) as follows:

$$V_{Drop} = V_0 - V_L$$
- Use the table below to determine the appropriate setting using the calculated V_{Drop} as a reference.

INTERNAL RESISTANCE COMPENSATION TABLE

Setting	V_{Drop}	Setting	V_{Drop}
2	11.44	17	1.34
3	7.60	18	1.27
4	5.72	19	1.20
5	4.57	20	1.14
6	3.81	21	1.09
7	3.27	22	1.04
8	2.86	23	0.99
9	2.54	24	0.95
10	2.28	25	0.91
11	2.08	26	0.88
12	1.90	27	0.85
13	1.76	28	0.82
14	1.63	29	0.79
15	1.52	30	0.76
16	1.43	31	0.74

FUNCTION 15 BATTERY VOLTS (Push 15)

This function allows for the adjustment of voltage range for controls equipped with the Battery Discharge Indication function. In order for the BDI to operate properly, the setting as shown in the table must be entered:

Battery Volts	Set Units
24 volts	Between 0 and 31
36 volts	Between 32 and 44
48 volts	Between 45 and 69
36/48 volts	Between 184 and 250
No BDI	Between 251 and 255

The following functions have function numbers larger than the numbers on the Handset keyboard. To access these functions, push the CONT key and the number shown in the instructions at the same time. THE SEAT SWITCH MUST BE OPEN.

FUNCTION 16 FIELD RAMP DOWN RATE WHILE IN REGENERATIVE BRAKING MODE (Push CONT 1)

Important Note: This function is used to optimize motor and control performance and this setting will be determined by GE and OEM engineers at the time of vehicle development. This setting must not be changed by field personnel without the permission of the OEM.

FUNCTION 17 JOYSTICK TIMER (Push CONT 2)

This function allows for the adjustment of the delay time from the point at which a direction is selected to actual vehicle movement.

Range	1.0 to 25.5 seconds
Setting	Between 0 and 255
Resolution	0.1 seconds per set unit
Example	Setting of 2 = 0.2 seconds

FUNCTION 18 ARMATURE CURRENT RAMP UP RATE WHILE IN REGENERATIVE BRAKING MODE (Push CONT 3)

Important Note: This function is used to optimize motor and control performance and this setting will be determined by GE and OEM engineers at the time of vehicle development. This setting must not be changed by field personnel without the permission of the OEM.

FUNCTION 19 NOT APPLICABLE

This function is not applicable to this type of control and should not be adjusted.

FUNCTION 20 NOT APPLICABLE

This function is not applicable to this type of control and should not be adjusted.

FUNCTION 21 NOT APPLICABLE

This function is not applicable to this type of control and should not be adjusted.

FUNCTION 22 NOT APPLICABLE

This function is not applicable to this type of control and should not be adjusted.

**FUNCTION 23 ERROR COMPENSATION
(Push CONT 8)**

This function is used to reduce the ripple in the field current due to the interaction between the motor field design and the digital field current regulation circuit. The value for this function will be defined to the vehicle manufacturer by the GE application engineer.

Important Note: The function is used to optimize motor and control performance and this setting will be determined by GE and OEM engineers at the time of vehicle development. This setting must not be changed by field personnel without the permission of the OEM.

**FUNCTION 24 FIELD WEAKENING START
(Push CONT 9)**

This function allows for setting the armature current at which minimum field current will be achieved.

Range	0 to 414 amps
Setting	0 to 255
Resolution	1.625 per set unit
Example	Setting of 20 = 32.5 amps

**FUNCTION 25 MONITOR
(Push CONT 10)**

This function allows the monitoring of certain control functions by looking directly at the RAM of the microprocessor. Because absolute memory locations need to be known, this function should not be used without detailed instructions from the GE application engineer.

To ensure optimum operation of the control, this function must be left with zero stored in this register.

**FUNCTION 26 RATIO
(Push CONT 11)**

This function sets the ratio between armature and field current when transitioning from minimum field to maximum field current. The setting represents the quantity of field current changed for each 1 amp of armature current changed.

Max Fld Ref	Max Change	Set	Resolution Per unit value	Example If set at 5
20	.24	0 to 10	0.024 amps	0.12 amps
30	.24	0 to 10	0.024 amps	0.12 amps
40	.27	0 to 10	0.027 amps	0.135 amps
50	.48	0 to 10	0.048 amps	0.24 amps
60	.48	0 to 10	0.048 amps	0.24 amps

FUNCTION 27 NOT APPLICABLE

This function is not applicable to this type of control and should not be adjusted.

**FUNCTION 28 STORED STATUS CODE COUNT
POINTER
(Push CONT 13)**

This register contains the location of the last stored status code recorded of the 16 stored status codes. These stored status codes have caused a PMT controller shutdown and/or disruption of normal vehicle operation.

To determine which stored status code was the last one recorded, read the number stored in Function 28. Using the **Memory Map** for your logic card, match the "**stored status code pointer number**" [the number shown in (*bold italics*) in the HS (Handset) number column] on the memory map, with the number obtained from Function 28. This will be the last stored status code recorded.

Note: When scrolling through the stored status code register, the register always starts at status code 1 and scrolls to status code 16. Instructions for scrolling the register are in section 5.3.2 of this instruction booklet.

Note: The following functions have function numbers larger than the numbers on the Handset keyboard. To access these functions, push the CONT key and the number shown in the following instructions at the same time. The seat switch must be closed.

FUNCTION 48 NOT APPLICABLE

This function is not applicable to this type of control and should not be adjusted.

FUNCTION 49 NOT APPLICABLE

This function is not applicable to this type of control and should not be adjusted.

FUNCTION 50 NOT APPLICABLE

This function is not applicable to this type of control and should not be adjusted.

FUNCTION 51 NOT APPLICABLE

This function is not applicable to this type of control and should not be adjusted.

FUNCTION 52 NOT APPLICABLE

This function is not applicable to this type of control and should not be adjusted.

FUNCTION 53 NOT APPLICABLE

This function is not applicable to this type of control and should not be adjusted.

FUNCTION 54 NOT APPLICABLE

This function is not applicable to this type of control and should not be adjusted.

FUNCTION 55 NOT APPLICABLE

This function is not applicable to this type of control and should not be adjusted.

FUNCTION 56 NOT APPLICABLE

This function is not applicable to this type of control and should not be adjusted.

FUNCTION 57 NOT APPLICABLE

This function is not applicable to this type of control and should not be adjusted.

FUNCTION 58 NOT APPLICABLE

This function is not applicable to this type of control and should not be adjusted.

FUNCTION 59 NOT APPLICABLE

This function is not applicable to this type of control and should not be adjusted.

FUNCTION 60 NOT APPLICABLE

This function is not applicable to this type of control and should not be adjusted.

FUNCTION 61 NOT APPLICABLE

This function is not applicable to this type of control and should not be adjusted.

FUNCTION 62 NOT APPLICABLE

This function is not applicable to this type of control and should not be adjusted.

FUNCTION 63 NOT APPLICABLE

This function is not applicable to this type of control and should not be adjusted.

Section 5.5 Summary of Current Limit Adjustments

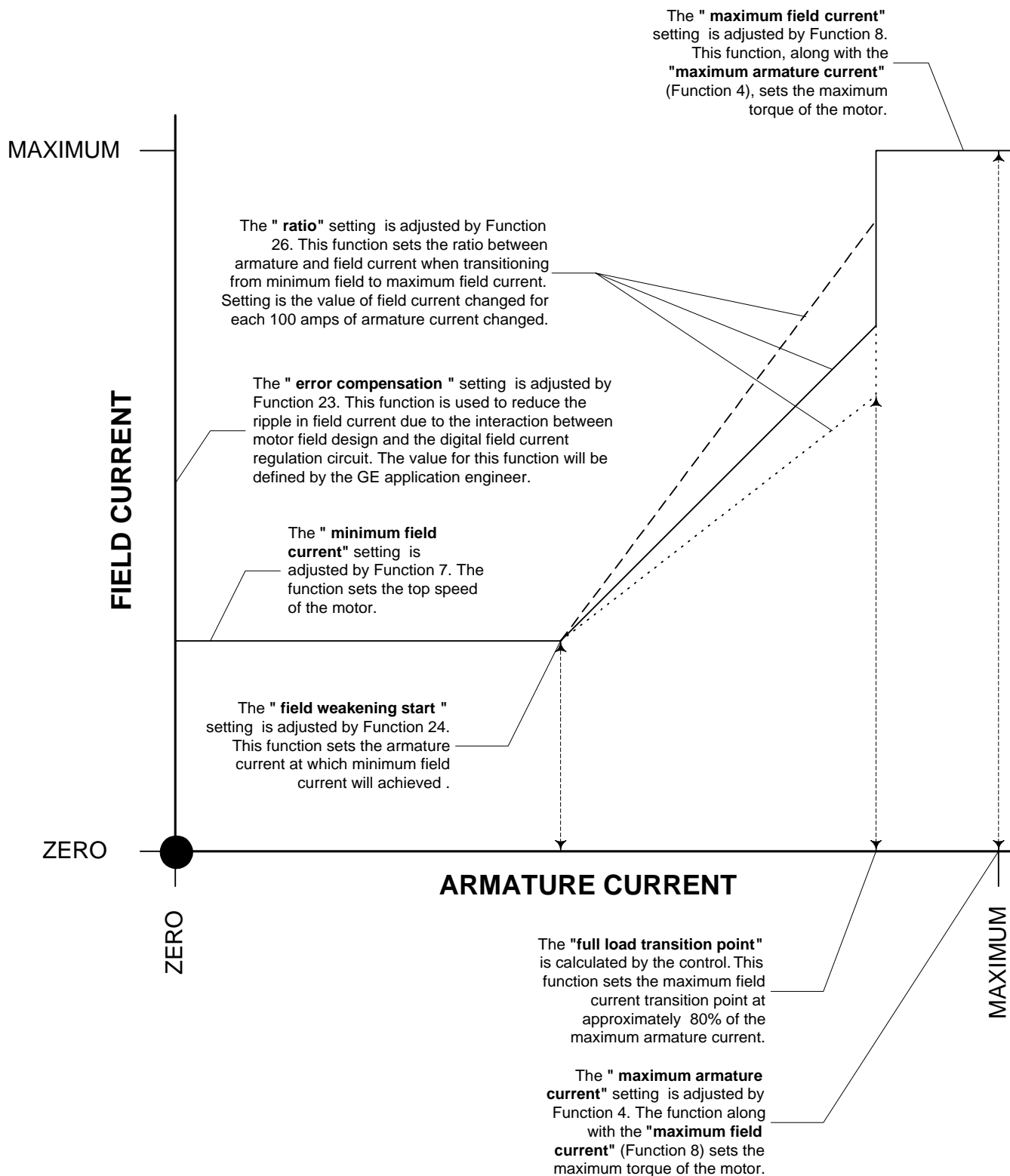

Section 6.0 DASH DISPLAYS

Section 6.1 Application

The SX family Standard and Interactive Dash Displays allow the operator and maintenance personnel easy access to truck operation information and real-time system diagnostics of the controller, motor and various accessories. Hourmeter readings, battery discharge information, maintenance information and system status codes are clearly displayed during startup and running modes. Shielded cable connections are made to the Dash Display by means of five (5) 22-gage wires to the "Y" Plug of the traction and hydraulic pump controls.

Section 6.2 Standard Dash Displays

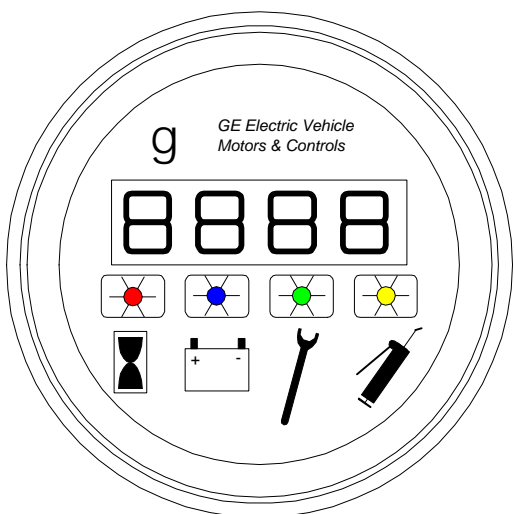

The GE Standard Dash Display is a four segment Light Emitting Diode (LED) instrument that displays the GE LX, ZX, and SX Status Codes, Hourmeter Readings, Battery Discharge Indication, and Maintenance Required Code. The four LED's above the symbols indicate the active readout mode.

Section 6.3 Interactive Custom Dash Displays

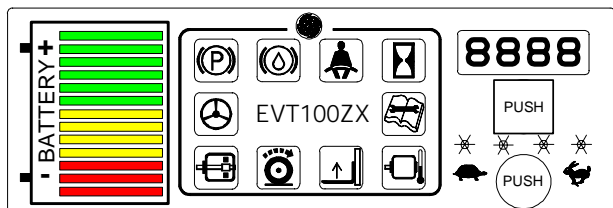

The Interactive Custom Dash Display allows the operator to select the best vehicle performance for changing factory (task) conditions. There are four (4) "operator interaction modes" that can be selected by depressing a push-button on the dash display.

From the Dash Display, the operator may select any of four pre-set interactive modes consisting of (4) Controlled Acceleration levels, (4) Field Weakening Pick Up levels and (4) Speed Limit levels.

These interactive modes are "pre-set" using the Handset (Functions 48 - 63) or a personal computer (Functions 97 - 112). This feature allows the operator to select the best vehicle performance for changing factory (task) conditions.

The table below outlines the normal logic flow for pre-setting the four interactive modes:

	Mode 1 Turtle	Mode 2	Mode 3	Mode 4 Rabbit
C/A Settings	=> Mode 2	=> Mode 3 =< Mode 1	=> Mode 4 =< Mode 2	=< Mode 3
FW Start Settings	=< Mode 2	=< Mode 3 => Mode 1	=< Mode 4 => Mode 2	=> Mode 3
Min. fld Setting	=> Mode 2	=> Mode 3 =< Mode 1	=> Mode 4 =< Mode 2	=< Mode 3
Ratio Setting	=> Mode 2	=> Mode 3 =< Mode 1	=> Mode 4 =< Mode 2	=< Mode 3

The Custom Dash Display incorporates all the features and functions of the Standard Dash Display, in addition to the following customer options:

- LED graphics to display Battery Discharge Indication status.
- Various LED indicators for Maintenance Required Status Codes. These can include options for traction, pump and power steer motors, hourmeter, over-temperature, seat belt, brake and other safety sensors.
- A push-button associated with the four segment LED that displays Status Codes can be used to scroll the last 16 "Stored Status Codes" that shut down vehicle operation with a PMT fault.

Section 6.3.1 Connections

Connections are made to the Dash Display with five (5) 22-gage wires to Plug "Y" of each control. Shielded cable is required to eliminate signal interference.

Section 6.3.2 Part Number

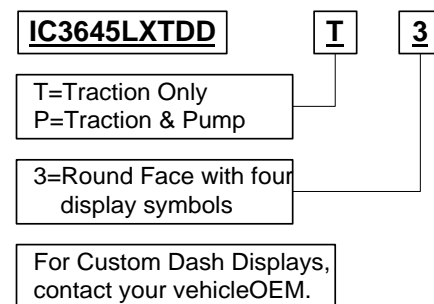

Section 6.3.3 Connector Reference Numbers

- AMP#102241-3 Dash Display mating plug
- AMP#1-87195-8 Dash Display mating pin
- 44A723596-G09 Dash Display plug kit
- AMP#175965-2 "Y" Plug
- AMP#175180-1 "Y" Plug receptacle

Section 6.4 Start-Up Display Sequence

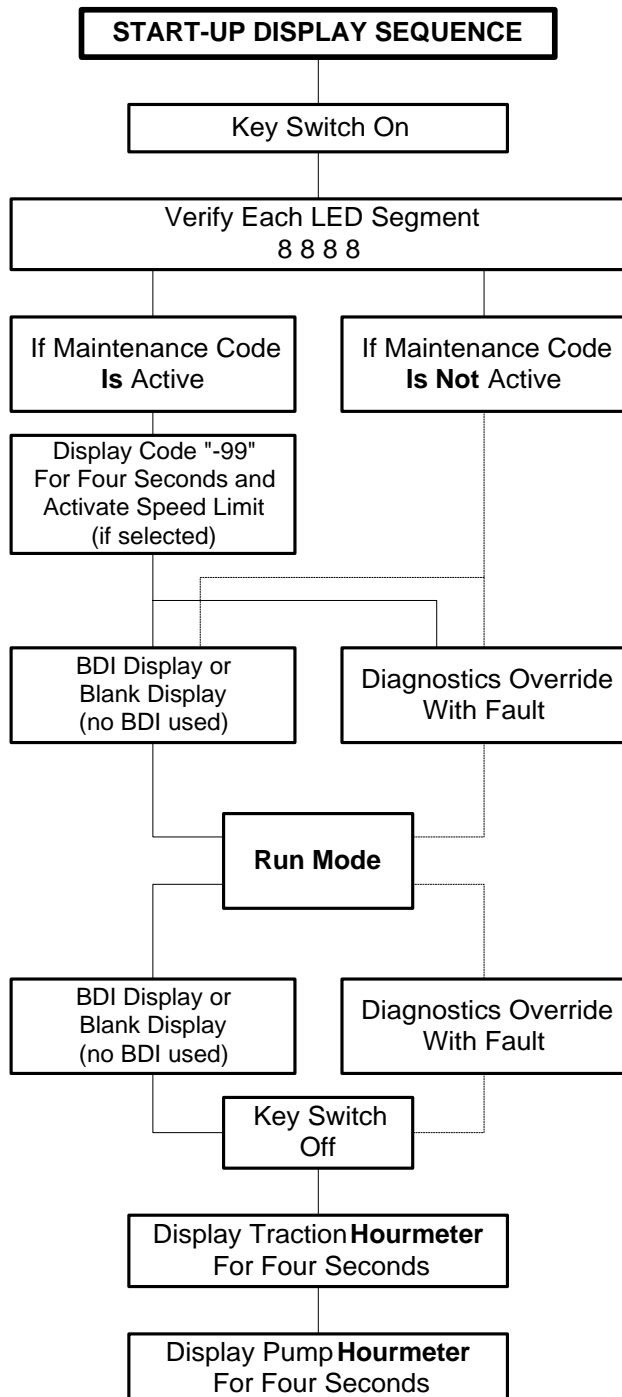

Section 6.5 Outline Drawings

For the standard GE traction dash display:

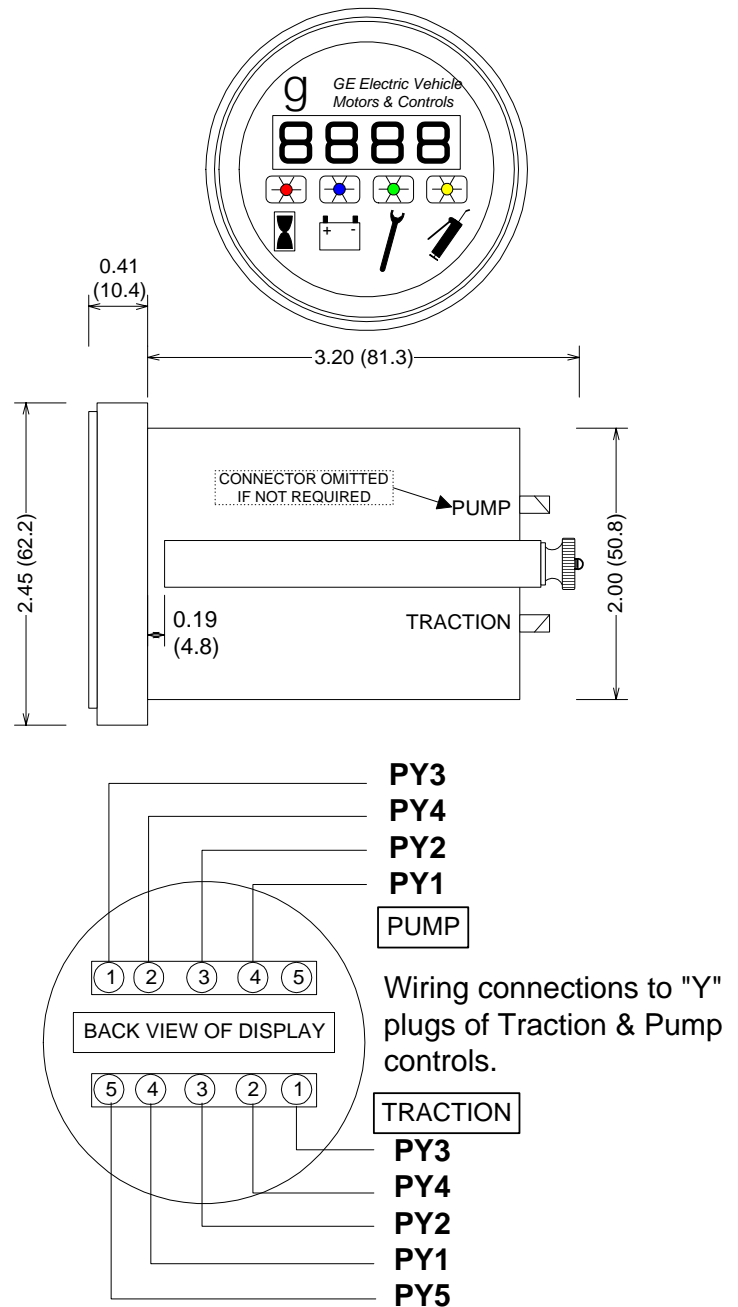

Section 6.6 Suggested Wiring Configuration for Use of GE
Standard Traction/Pump Dash Display with Dual Motor
Traction System

NOTE: USE SHIELDED
CABLE FOR DASH DISPLAY
CONNECTIONS, WITH THE
BARE WIRE CONNECTED
TO PY4 (BATTERY
NEGATIVE)

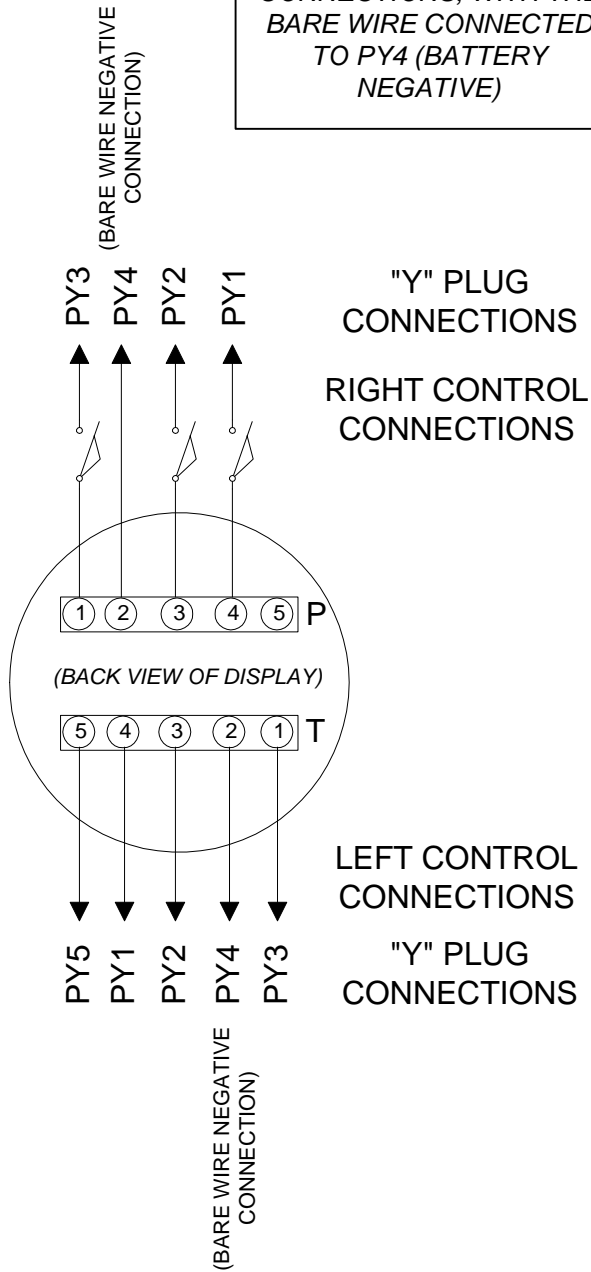

Section 7.0 Memory Maps

Section 7.1 Typical Memory Map for Dual Motor Proportioning Controls

E ²	Func No.	HS No.	Traction Control Function	Access By	Restrictions
0	1	1	Tachometer Sample Rate	HS or PC	None
1	2	2	Creep Speed	HS or PC	None
2	3	3	Armature Controlled Acceleration - H.S.	HS or PC	None
3	4	4	Armature Current Limit	HS or PC	None
4	5	5	Plugging Current Limit	HS or PC	None
5	6	6	Armature Controlled Acceleration - L.S.	HS or PC	None
6	7	7	Minimum Field Current	HS or PC	None
7	8	8	Maximum Field Current	HS or PC	None
8	9	9	Regen Braking Current Limit	HS or PC	None
9	10	10	Max Field Current for Regen	HS or PC	None
10	11	11	"Low Speed" Speed Limit	HS or PC	None
11	12	12	"High Speed" Speed Limit	HS or PC	None
12	13	13	Field Ramp Up Rate in Regen	HS or PC	None
13	14	14	Internal Resistance Compensation	HS or PC	None
14	15	15	Battery Volts Select	HS or PC	None
15	16	16	Field Ramp Down Rate in Regen	HS or PC	None
16	17	17	Joystick Timer	HS or PC	None
17	18	18	Armature Current Ramp Up Rate in Regen	HS or PC	None
18	19	19	Not Used	HS or PC	None
19	20	20	Not Used	HS or PC	None
20	21	21	Not Used	HS or PC	None
21	22	22	Not Used	HS or PC	For DD on power up
22	23	23	Error Compensation	HS or PC	None
23	24	24	FW Start	HS or PC	None
24	25	25	Monitor	HS or PC	GE Temporary Storage
25	26	26	Ratio	HS or PC	GE Temporary Storage
26	27	27	Not Used	HS or PC	GE Temporary Storage
27	28	28	Stored Status Code Count Pointer	HS or PC	None
28	29	29	Not Used	HS or PC	None
29	30	30	Not Used	HS or PC	None
30	31		Aux HM (Tens/Ones)	PC Only	None
31	32		Aux HM (Thou/Hun)	PC Only	None
32	33	(18)	Stored Status Code #1	PC Only	Reset to Zero Only
33	34		BDI 1	PC Only	Reset to Zero Only
34	35		Hours (Tens/Ones) 1	PC Only	Reset to Zero Only
35	36		Hours (Thou/Hun) 1	PC Only	Reset to Zero Only
36	37	(20)	Stored Status Code #2	PC Only	Reset to Zero Only
37	38		BDI 2	PC Only	Reset to Zero Only
38	39		Hours (Tens/Ones) 2	PC Only	Reset to Zero Only
39	40		Hours (Thou/Hun) 2	PC Only	Reset to Zero Only
40	41	(22)	Stored Status Code #3	PC Only	Reset to Zero Only
41	42		BDI 3	PC Only	Reset to Zero Only
42	43		Hours (Tens/Ones) 3	PC Only	Reset to Zero Only
43	44		Hours (Thou/Hun) 3	PC Only	Reset to Zero Only

E ²	Func No.	HS No.	Traction Control Function	Access By	Restrictions
45	46		BDI 4	PC Only	Reset to Zero Only
46	47		Hours (Tens/Ones) 4	PC Only	Reset to Zero Only
47	48		Hours (Thou/Hun) 4	PC Only	Reset to Zero Only
48	49	(26)	Stored Status Code #5	PC Only	Reset to Zero Only
49	50		BDI 5	PC Only	Reset to Zero Only
50	51		Hours (Tens/Ones) 5	PC Only	Reset to Zero Only
51	52		Hours (Thou/Hun) 5	PC Only	Reset to Zero Only
52	53	(28)	Stored Status Code #6	PC Only	Reset to Zero Only
53	54		BDI 6	PC Only	Reset to Zero Only
54	55		Hours(Tens/Ones) 6	PC Only	Reset to Zero Only
55	56		Hours(Thou/Hun) 6	PC Only	Reset to Zero Only
56	57	(30)	Stored Status Code #7	PC Only	Reset to Zero Only
57	58		BDI 7	PC Only	Reset to Zero Only
58	59		Hours(Tens/Ones) 7	PC Only	Reset to Zero Only
59	60		Hours(Thou/Hun) 7	PC Only	Reset to Zero Only
60	61	(32)	Stored Status Code #8	PC Only	Reset to Zero Only
61	62		BDI 8	PC Only	Reset to Zero Only
62	63		Hours;(Tens/Ones) 8	PC Only	Reset to Zero Only
63	64		Hours(Thou/Hun) 8	PC Only	Reset to Zero Only
64	65	(34)	Stored Status Code #9	PC Only	Reset to Zero Only
65	66		BDI 9	PC Only	Reset to Zero Only
66	67		Hours(Tens/Ones) 9	PC Only	Reset to Zero Only
67	68		Hours(Thou/Hun) 9	PC Only	Reset to Zero Only
68	69	(36)	Stored Status Code #10	PC Only	Reset to Zero Only
69	70		BDI 10	PC Only	Reset to Zero Only
70	71		Hours(Tens/Ones) 10	PC Only	Reset to Zero Only
71	72		Hours(Thou/Hun) 10	PC Only	Reset to Zero Only
72	73	(38)	Stored Status Code #11	PC Only	Reset to Zero Only
73	; 74		BDI 11	PC Only	Reset to Zero Only
74	75		Hours(Tens/Ones) 11	PC Only	Reset to Zero Only
75	76		Hours(Thou/Hun) 11	PC Only	Reset to Zero Only
76	77	(40)	Stored Status Code #12	PC Only	Reset to Zero Only
77	78		BDI 12	PC Only	Reset to Zero Only
78	79		Hours(Tens/Ones) 12	PC Only	Reset to Zero Only
79	80	.	Hours(Thou/Hun) 12	PC Only	Reset to Zero Only
80	81	(42)	Stored Status Code #13	PC Only	Reset to Zero Only
81	82		BDI 13	PC Only	Reset to Zero Only
82	83		Hours(Tens/Ones) 13	PC Only	Reset to Zero Only
83	84		Hours(Thou/Hun) 13	PC Only	Reset to Zero Only
84	85	(44)	Stored Status Code # 14	PC Only	Reset to Zero Only
85	86		BDI 14	PC Only	Reset to Zero Only
86	87		Hours(Tens/Ones) 14	PC Only	Reset to Zero Only
87	88		Hours(Thou/Hun) 14	PC Only	Reset to Zero Only
88	89	(46)	Stored Status Code # 15	PC Only	Reset to Zero Only
89	90		BDI 15	PC Only	Reset to Zero Only
90	91		Hours (Tens/Ones) 15	PC Only	Reset to Zero Only
91	92		Hours (Thou/Hun) 15	PC Only	Reset to Zero Only

E ²	Func No.	HS No.	Traction Control Function	Access By	Restrictions
92	93	(48)	Stored Status Code #16	PC Only	Reset to Zero Only
94	95		Hours (Tens/Ones) 16	PC Only	Reset to Zero Only
95	96		Hours (Thou/Hun) 16	PC Only	Reset to Zero Only
96	67	48	Dash Display CA-1		
97	98	49	Dash Display FWS-1/Ratio2-1	HS or PC	None
98	99	50	Dash Display Min Fld-1	HS or PC	None
99	100	51	Dash Display If/Im Ratio-1/ SL-1	HS or PC	None
100	101	52	Dash Display CA-2	HS or PC	None
101	102	53	Dash Display FWS-2/Ratio2-2	HS or PC	None
102	103	54	Dash Display Min Fld-2	HS or PC	None
103	104	55	Dash Display If/Im Ratio-2/ SL-2	HS or PC	None
104	105	56	Dash Display CA-3	HS or PC	None
105	106	57	Dash Display FWS-3/Ratio2-3	HS or PC	None
106	107	58	Dash Display Min Fld-3	HS or PC	None
107	108	59	Dash Display If/Im Ratio-3/ SL-3	HS or PC	None
108	109	60	Dash Display CA-4	HS or PC	None
109	110	61	Dash Display FWS-4/Ratio2-4	HS or PC	None
110	111	62	Dash Display Min Fld-4	HS or PC	None
111	112	63	Dash Display If/Im Ratio-4/ SL-4	HS or PC	None
112	113		Secure HM (Tens/Ones)	PC Only	OEM Read Only
113	114		Secure HM (Thou/Hun)	PC Only	OEM Read Only
114	115		Secure Aux HM (Tens/Ones)	PC Only	OEM Read Only
115	116		Secure Aux HM (Thou/Hun)	PC Only	OEM Read Only
116	117		Reserved	PC Only	GE Future Use
117	118		Reserved	PC Only	GE Future Use
118	119		Reserved	PC Only	GE Future Use
119	120		Reserved	PC Only	GE Future Use
120	121		OEM Use	PC Only	None
121	122		OEM Use	PC Only	None
122	123		OEM Use	PC Only	None
123	124		OEM Use	PC Only	None
124	125		OEM Use	PC Only	None
125	126		OEM Use	PC Only	None
126	127		OEM Use	PC Only	None
127	128		OEM Use	PC Only	None

Numbers in **(bold italics)** are Stored Status Code pointers.